

**LG946L轮式装载机  
零部件图册**

**LG946L WHEEL LOADER PARTS CATALOG**

山东临工工程机械有限公司

**SHANDONG LINGONG CONSTRUCTION MACHINERY CO.,LTD.**

## 配件与服务 Spare parts and services

对于山东临工机器的所有者来说，只有山东临工配件和服务才能够使您的机器更好地保持原有的特性。

For the owner of the machines of SDLG, only the spare parts and services of SDLG can make your machine to better maintain the original features.

只有山东临工才能够为您提供完美匹配且优质纯正的配件和对您的机器了如指掌的专业维修人员。这样才能保证及其可持续的高产能和更长的使用寿命。

Only SDLG is able to provide you with the perfect match of pure quality spare parts for your machine and knowledge of professional maintenance staff. Only in this way it can ensure sustainable high productivity and longer service life.

## LG946L轮式装载机 零部件图册 LG946L WHEEL LOADER PARTS CATALOG

2010年12月 第1版 第1次印刷

2010-12 Version 1 Printed 1

---

山 东 临 工 工 程 机 械 有 限 公 司  
SHANDONG LINGONG CONSTRUCTION MACHINERY CO.,LTD.

地址：中国·临沂经济开发区临工工业园

Add: Lingong Industry Park, Linyi Economic Development Zone, Shandong, China

电话：86-0539-8785668

Tel: 86-0539-8785624/86-0531-66590955

传真：86-0539-8785698

Fax: 86-0539-8785618/86-0531-66590959

技术服务：86-0539-8785800 400-6587999

Web: [www.sdlg.cn](http://www.sdlg.cn)

# 前言

LG946L轮式装载机零部件图册，是为了方便用户使用、维修和保养而绘制的，以供在使用过程中查阅及参考，也可帮助用户了解本机的结构和装配关系。发动机的零部件详见其随机资料，本图册不再绘出。

本图册按系统划分绘制出了各零部件的图形及相互装配关系。凡装机后不可拆卸的部件（如焊接件、铆合件），只标出部件代号，不另列其组成零件。本图册明细表采用中英文对照编排。

本图册根据LG946L标准配置编绘，其它非标准配置，可参照执行，详情请咨询山东临工、或当地经销商、或登录山东临工网站查询。随着科技的进步，产品将会不断改进，故本图册的内容可能会有部分与以后的产品不一致，恕不另行通知。敬请用户在订购配件时，指明所购整车的出厂日期和编号。

编者

2012年8月

# FOREWORD

THIS PARTS LIST OF LG946L WHEEL LOADER IS MADE FOR THE CONVENIENCE OF USERS TO USE ,REPAIR AND MAINTAIN THE MACHINE,AND IT CAN BE REFERED IN THE PROCESS OF USING.IT CAN ALSO HELP THE USERS TO BE FAMILIAR WITH THE CONSTRUCTION AND ASSEMBLY RELATION OF THE MACHINE. THE PART OF THE ENGINE IS SHOWED IN DETAIL IN ITS STRUCTION HANDBOOK.SO THIS CATALOG DOES NOT CONTAIN THE ENGING PART LIST.

THE CATALOG CONTAINS THE PART DRAWINGS OF DEFERENT ASSEMBLIES,SHOWING THE SHAPE OF THE PARTS AS WELL AS THE ASSEMBLING RELATION.THE COMPONENTS WHICH CAN NOT BE TAKEN APART (SUCH AS THE WELDMENT OR RIVETED ASSEMBLIES) ARE INDICATED ONLY BY THEIR COMPONET NUMBERS WITHOUT THE CONSISTING PART NUMBERS .THE LIST IN THE CATALOG IS ARRANGED BY CHINESE VERSUS ENGLISH.

THIS CATALOG IS BASED ON THE LG946L STANDARD PRODUCT,THE OTHERS OF NONSTANDARD PRODUCT CAN REFER THE STANDARD PRODUCT,AND THE DETAILED INFORMATION CAN BE KNOWN FROM SHANDONG LINGONG,THE LOACAL DEALER OR LINGONG WEBSITE ALTERATIONS IN DESIGN ARE NECESSARILY WITH THE THECHNICAL DEVELOPMENT SO SOME CONTENT IN THE CATALOG PROBABLY IS NOT CONSISTANT WITH THE FUTURE PRODUCTS,AND THIS WILL NOT NOTICE USERS.THEREFORE WHEN ORDERING SPARE PARTS, USERS ARE KINDLY REQUSETED TO INFORM US THE MANUFACTURING DATE AND BATCHNUMBER OF THE WHEEL LOADER.  
THE COMPILER  
2012.8



## 目录 CONTENTS

### A. 发动机系统

#### A. DIESEL ENGINE SYSTEM

发动机总成 .....	A1-2901001761
DIESEL ENGINE ASSEMBLY .....	A1-2901001761
燃油箱总成 .....	A2-2902000871
FUEL TANK ASSY .....	A2-2902000871
散热器总成 .....	A3-2903001219
RADIATOR ASSEMBLY .....	A3-2903001219

### B. 变矩器系统

#### B. TORQUE CONVERTER SYSTEM

变矩器总成 .....	B1-2904000888
TORQUE CONVERTER ASSEMBLY .....	B1-2904000888
变矩器YJSW315-6G .....	B2-4110000841
.....	B2-4110000841
滤清器QF60M33G-1 (410708) .....	B4-4110000507
CLEANER QF60M33G-1 (410708) .....	B4-4110000507
滤清器QF60M33G-1(371328) .....	B5-4110000507
CLEANER QF60M33G-1(371328) .....	B5-4110000507

### C. 变速箱系统

#### C. TRANSMISSION SYSTEM

变速箱总成 .....	C1-2905001713
TRANSMISSION ASSEMBLE .....	C1-2905001713

A307A变速箱总成 .....	C2-2905001633
A307A TRANSMISSION ASSEMBLE .....	C2-2905001633
三轴总成 .....	C3-2030900027
3RD SHAFT ASS'Y .....	C3-2030900027
四轴总成（ I ） .....	C4-2030900026
4TH SHAFT ASS'Y（ I ） .....	C4-2030900026
四轴总成（ II ） .....	C6-2905001656
4TH SHAFT ASS'Y（ II ） .....	C6-2905001656
输出轴总成 .....	C7-2905001792
OUTPUT SHAFT ASSEMBLY .....	C7-2905001792

#### D. 变速操纵系统

#### D. TRANSMISSION CONTROL SYSTEM

变速操纵系统 .....	D1-2906000775
TRANSMISSION CONTROL SYSTEM .....	D1-2906000775
变速操纵机构LG936L .....	D2-4110000746
TRANSMISSION CONTROL INSTITUTION LG936L .....	D2-4110000746
变速操纵阀LG03-BSF(350802) .....	D3-4120000064
TRANSMISSION CONTROL LG03-BSF VALVE(350802) .....	D3-4120000064

#### E. 驱动桥系统

#### E. AXLE SYSTEM

前桥总成 .....	E1-2907001276
FRONT AXLE ASSEMBLY .....	E1-2907001276

前主传动总成 .....	E2-2907000106
FRONT AXLE MAIN DRIVE ASSEMBLY .....	E2-2907000106
传动轴总成 .....	E4-2908000802
DRIVE SHAFT ASSEMBLY .....	E4-2908000802
后桥总成 .....	E5-2909000767
REAR AXLE ASSEMBLY .....	E5-2909000767
后主传动总成 .....	E6-2909000106
REAR AXLE MAIN DRIVE ASSEMBLY .....	E6-2909000106
轮边减速器总成 .....	E7-2907000927
FINAL DRIVE ASSEMBLY .....	E7-2907000927
制动钳(371328) .....	E8-4120001739
DISK BRAKE(371328) .....	E8-4120001739
制动钳(371104) .....	E20-4120001739
DISC BRAKE(371104) .....	E20-4120001739

**F. 工作装置液压系统**

**F. IMPLEMENT HYDRAULIC SYSTEM**

液压操纵总成 .....	F1-2912001775
HYDRAULIC CONTROL SYSTEM .....	F1-2912001775
工作泵总成 .....	F2-2911000893
WORKING PUMP ASSEMBLY .....	F2-2911000893
举升缸总成 .....	F3-2913001265
LIFTING CYLINDER ASSEMBLY .....	F3-2913001265



转斗缸总成 .....	F4-2914001124
DUMP CYLINDER ASSEMBLY .....	F4-2914001124
液压油箱总成 .....	F5-2910001312
HYDRAULIC TANK ASSEMBLY .....	F5-2910001312
转斗油缸（371401） .....	F6-4120002763
TILT CYLINDER .....	F6-4120002763
动臂油缸（371401） .....	F8-4120002522
LIFT ARM CYLINDER（371401） .....	F8-4120002522
多路阀DFS-32-16（331001） .....	F11-4120002038
MULTIPLE UNIT VALVE DFS-32-16 .....	F11-4120002038

## H. 工作装置

### H. WORKING EQUIPMENT

工作装置 .....	H1-2916000805
WORKING EQUIPMENT .....	H1-2916000805

## I. 转向系统

### I. STEERING SYSTEM

转向泵总成 .....	I1-2919000907
STEERING PUMP ASSEMBLY .....	I1-2919000907
转向器总成 .....	I2-2920000879
STEERING GEAR .....	I2-2920000879
转向缸总成 .....	I3-2921000401
STEERING CYLINDER ASSEMBLY .....	I3-2921000401

转向油缸 (371401) .....	I4-4120001004
STEERING CYLINDER (371401) .....	I4-4120001004
转向油缸 (371368) .....	I5-4120001004
STEERING CYLINDER (371368) .....	I5-4120001004

**J. 制动系统**

**J. BRAKE SYSTEM**

行车制动总成 .....	J1-2922001028
SERVICE BRAKE SYSTEM .....	J1-2922001028
储气罐 .....	J2-2922000053
AIR RESERVOIR .....	J2-2922000053
加力泵(340201) .....	J3-4120000090
BRAKE BOOSTER .....	J3-4120000090
驻车制动系统 .....	J4-2923000401
PARKING BRAKE SYSTEM .....	J4-2923000401
气制动阀 (330604) .....	J6-4120001795
BRAKE CONTROL VALVE (330604) .....	J6-4120001795

**K. 车架**

**K. FRAME**

前车架总成 .....	K1-2925000818
FRONT FRAME .....	K1-2925000818
灯架及挡泥瓦 .....	K2-2925000818
LAMP FRAME AND FRONT FENDER .....	K2-2925000818

后车架及配件 .....	K3-2927000923
REAR FRAME AND ACCESSORIES .....	K3-2927000923
配重铁总成 .....	K4-2928000820
COUNTER WEIGHT .....	K4-2928000820
<b>L. 驾驶室</b>	
<b>L. CAB GROUP</b>	
驾驶室总成 .....	L1-2929001005
CAB ASSEMBLY .....	L1-2929001005
驾驶室 .....	L2-2929000865
CAB GROUP .....	L2-2929000865
操作台架 .....	L3-2931001340
BENCH GROUP .....	L3-2931001340
座椅总成(321013) .....	L4-2930000755
SEAT ASSEMBLY .....	L4-2930000755
操纵箱总成 .....	L5-2932000904
OPERATE BOX .....	L5-2932000904
座椅总成(331002) .....	L7-2930000755
SEAT ASSEMBLY .....	L7-2930000755
<b>M. 覆盖件系统</b>	
<b>M. CONVER SYSTEM</b>	
发动机罩总成 .....	M1-2933002433
ENGINE HOOD ASSEMBLY .....	M1-2933002433

左台架总成 .....	M2-2934001782
LEFT BENCH GROUP .....	M2-2934001782
右台架总成 .....	M3-2934001783
RIGHT BENCH GROUP .....	M3-2934001783
后转向灯罩 .....	M4-2934001568
REAR STEERING LAMP HOOD .....	M4-2934001568
标志与标识 .....	M5-2936001223
SIGN AND LOGO .....	M5-2936001223
下梯总成 .....	M7-2934001219
DOWN LADDER ASSEMBLY .....	M7-2934001219
<b>N. 空调系统</b>	
<b>N. AIR CONDITIONER SYSTEM</b>	
暖风机 .....	N1-2935000888
WARMING MACHINE .....	N1-2935000888
暖风机 .....	N3-4190000917
WARMING MACHING .....	N3-4190000917
<b>O. 电气系统</b>	
<b>O. ELECTRIC SYSTEM</b>	
电气系统 .....	O1-2937001594
ELECTRIC SYSTEM .....	O1-2937001594
仪表盘总成 .....	O2-2937001604
PANEL ASSEMBLY .....	O2-2937001604

**A 发动机系统**  
**DIESEL ENGINE SYSTEM**

山东临工工程机械有限公司  
**SHANDONG LINGONG CONSTRUCTION MACHINERY CO.,LTD.**



发动机总成 DIESEL ENGINE ASSEMBLY

序号 Key	零件代号 Part No.	名称 Description	是否配件 Spare parts Y/N	数量 Qty	备注 Remarks
1	4013000028	螺母GB6170-M6EpZn-8	N	1	
2	4011000101	螺栓GB5783-M6*20EpZn-8.8	N	1	
3	4015000035	垫圈GB93-6-65Mn	N	1	
4	4120000096	油门踏板ZY75-00	Y	1	
5	4013000033	螺母GB6170-M8EpZn-8	N	1	
6	29010017891	操纵软轴	Y	1	
7	29010014571	操纵软轴	Y	1	
8	4090000177	胶管HG2491-16*2600	Y	1	
9	4017000024	环箍QC390-D26	N	1	
10	4090000178	胶管HG2491-16*1700	Y	1	
11	4041000829	管夹LGB167-0322	Y	1	
12	4041000876	缓冲套LGB123-0322	Y	1	
13	4011000461	螺栓GB16674-M8*16EpZn-8.8	N	1	
14	4120000067	暖风机水阀LG12-NFJSF	Y	1	
15	4110000846	发动机总成WP6G160E201 (DHB06G0055)	Y	1	
16	29010017901	上盖板	Y	1	
17	4011000081	螺栓GB5783-M10*20EpZn-8.8	N	1	
18	4015000197	垫圈GB96.1-10EpZn-300HV	N	1	
19	4015000207	垫圈GB97.1-6EpZn-300HV	N	1	
20	4041000025	螺塞LGB135-01017	Y	1	
21	4015000139	垫圈JB1002-10-T2	N	1	
22	29010006681	连接叉	Y	1	



**发动机总成 DIESEL ENGINE ASSEMBLY**

序号 Key	零件代号 Part No.	名称 Description	是否配件 Spare parts Y/N	数量 Qty	备注 Remarks
23	4016000138	销轴GB882-B6*22EpZn-35	PIN GB882-B6*22EpZn-35	N	1
24	4016000100	开口销GB91-2*20EpZn-Q235A	SPLINT PIN GB91-2*20EpZn-Q235A	N	1
25	4016000120	开口销GB91-2*12EpZn-Q235A	SPLINT PIN GB91-2*12EpZn-Q235A	N	1
26	29010001071	螺栓轴	BOLT SHAFT	Y	1
27	4014000020	螺钉GB75-M6*10EpZn-22H	SCREW GB75-M6*10EpZn-22H	N	1
28	4015000176	垫圈GB97.1-20EpZn-300HV	WASHER GB97.1-20EpZn-300HV	N	1
29	4015000030	垫圈GB93-20-65Mn	WASHER GB93-20-65Mn	N	1
30	4013000020	螺母GB6170-M20EpZn-8	NUT GB6170-M20EpZn-8	N	1
31	4011000236	螺栓GB5782-M20*130EpZn-8.8	BOLT GB5782-M20*130EpZn-8.8	N	1
32	4110000460	减震器CBB95-2	SHOCK ABSORBER CBB95-2	Y	1
33	29050000121	垫圈	WASHER	Y	1
34	29010008401	回油接头	CONNECTOR	Y	1
35	4015000025	垫圈GB93-10-65Mn	WASHER GB93-10-65Mn	N	1
36	4013000007	螺母GB6170-M10EpZn-8	NUT GB6170-M10EpZn-8	N	1
37	29010000111	双头螺栓	DOUBLE BOLT	Y	1
38	29010008701	输油胶管	TUBE PIPE	Y	1
39	29220001191	直接头	CONNECTOR	Y	1
40	26370001951	管夹	CLAMP	Y	1
41	29010019241	支架	BRACKET	Y	1
42	29010019251	软管	TUBE	Y	1
43	4011000488	螺栓GB16674-M10*16EpZn-8.8	BOLT GB16674-M10*16EpZn-8.8	N	1
44	29010017931	油水分离器支架	BRACKET	Y	1



**发动机总成 DIESEL ENGINE ASSEMBLY**

序号 Key	零件代号 Part No.	名称 Description	是否配件 Spare parts Y/N	数量 Qty	备注 Remarks	
45	4120000084	油水分离器组合阀ST-50G	AIR DYER ST-50G	Y	1	
46	4120000750	金属软管	METAL TUBE	Y	1	
47	29220000171	垫圈	WASHER	Y	1	
48	29010022651	直角接头	JOINT	Y	1	
49	4110000054305	旋装式滤清器01174421	SPIN-ON FILTER 01174421	Y	1	
50	7200002385	柴滤芯(13020488)PTD226B-6(13020158)-043	OIL FILTER 13020488	Y	1	
51	4110000846001	空滤滤芯13023205	ELEMENT-AIR FILTER 13023205	Y	1	
52	26350001171	暖风机水管过渡接头	JOINT		1	



燃油箱总成 FUEL TANK ASSY

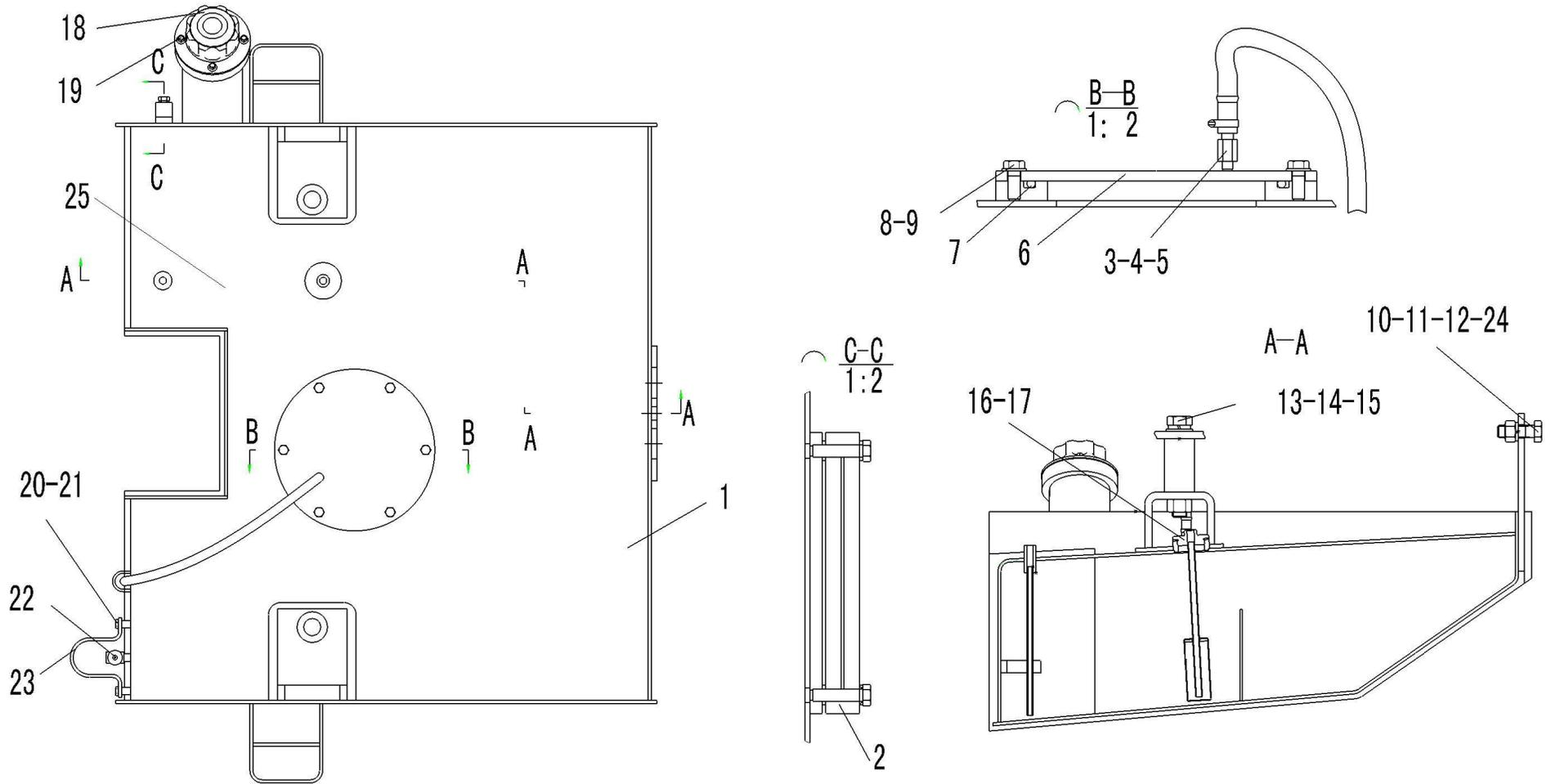

序号 Key	零件代号 Part No.	名称 Description	是否配件 Spare parts Y/N	数量 Qty	备注 Remarks	
1	29020008721	燃油箱体	FUEL TANK	N	1	
2	4120000093	液位计YWZ-200	GAUGE LEVEL YWZ-200	Y	1	
3	29020006561	透气钢管	BREATHER TUBE	Y	1	
4	4017000015	喉箍JB8870-d25	CLAMP COLLAR JB8870-d25	N	1	
5	4120000046	胶管JB8406-A10*560	HOSE JB8406-A10*560	Y	1	
6	29020000041	盖板	PLATE	Y	1	
7	4030000022	O形圈GB3452.1-200*7.00G	O-RING GB3452.1-200*7.00G	Y	1	
8	4011000082	螺栓GB5783-M10*25EpZn-8.8	BOLT GB5783-M10*25EpZn-8.8	N	6	
9	4015000162	垫圈GB97.1-10EpZn-300HV	WASHER GB97.1-10EpZn-300HV	N	6	
10	4011000114	螺栓GB5785-M20*2*60EpZn-8.8	BOLT GB5785-M20*2*60EpZn-8.8	N	1	
11	4013000040	螺母GB6171-M20*2EpZn-8	NUT GB6171-M20*2EpZn-8	N	1	
12	4015000030	垫圈GB93-20-65Mn	WASHER GB93-20-65Mn	N	1	
13	4011000117	螺栓GB5785-M24*2*150EpZn-8.8	BOLT GB5785-M24*2*150-8.8	N	2	
14	4015000167	垫圈GB97.1-24EpZn-300HV	WASHER GB97.1-24EpZn-300HV	N	2	
15	4015000031	垫圈GB93-24-65Mn	WASHER GB93-24-65Mn	N	2	
16	2010900046	滤油器总成	FUEL FILTER	Y	1	
17	29020007931	垫圈	WASHER	Y	1	
18	4110000612	加油滤清器QL8	GASOLINE FILTER QL8	Y	1	
19	4011000461	螺栓GB16674-M8*16EpZn-8.8	BOLT GB16674-M8*16EpZn-8.8	N	4	
20	4011000106	螺栓GB5783-M8*25EpZn-8.8	BOLT GB5783-M8*25EpZn-8.8	N	2	
21	4015000072	垫圈GB97.1-8EpZn-300HV	WASHER GB97.1-8EpZn-300HV	N	2	
22	4120000099	球阀MBS216-1/2"	BALL VALVE	Y	1	

燃油箱总成 FUEL TANK ASSY

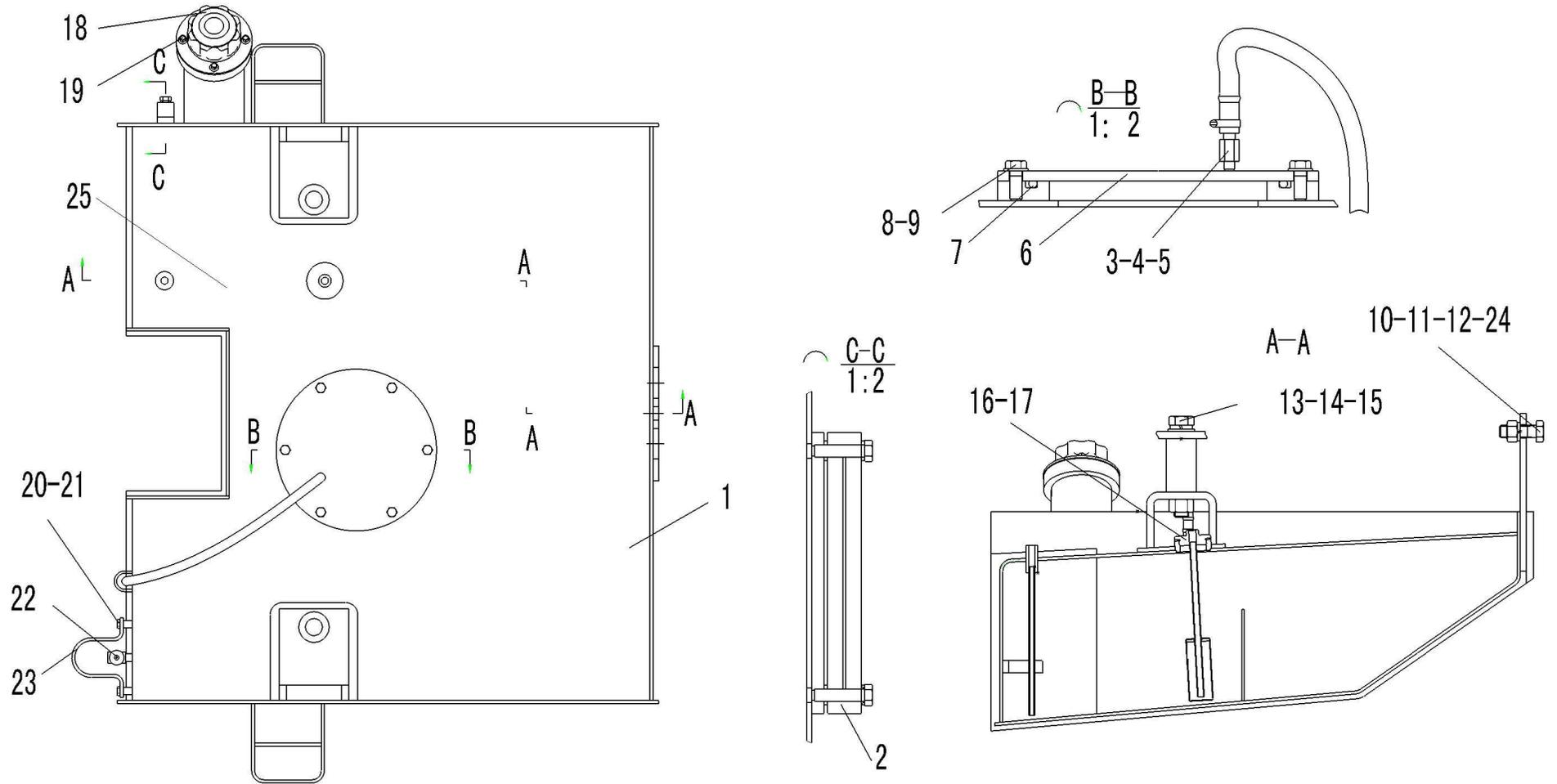

序号 Key	零件代号 Part No.	名称 Description	是否配件 Spare parts Y/N	数量 Qty	备注 Remarks
23	29020006591	护板	Y	1	
24	4015000176	垫圈GB97.1-20EpZn-300HV	N	1	
25	29020008711	燃油箱总成	Y	1	





散热器总成 RADIATOR ASSEMBLY

序号 Key	零件代号 Part No.	名称 Description	是否配件 Spare parts Y/N	数量 Qty	备注 Remarks	
1	4011000458	螺栓GB16674-M8*20EpZn-8.8	BOLT GB16674-M8*20Ep.Zn-8.8	N	8	
2	29330021831	压板	PLATE	Y	1	
3	29030010881	挡风板	WINDSHIELD	Y	1	
4	4017000007	喉箍JB8870-d60	CLAMP JB8870-d60	N	4	
5	29030012201	上水管	UPSIDE COOLANT PIPE	Y	1	
6	4110000963	散热器总成LG946-01	radiator assembly LG946	Y	1	
7	4011000481	螺栓GB16674-M8*30EpZn-8.8	BOLT GB16674-M8*30Ep.Zn-8.8	N	4	
8	4030000279	O形圈GB3452.1-25.0*3.55G	O-RING GB3452.1-25*3.55G	Y	2	
9	4041000137	分体法兰LGB117-306400	FLANGE LGB117306400	Y	2	
10	4011000474	螺栓GB16674-M10*25EpZn-8.8	BOLT GB16674-M10*25EpZn-8.8	N	8	
11	4120001061	液压油散热器B1342	OIL COOLER B1342	Y	1	
12	29030000041	管夹	CLAMP	Y	1	
13	4011000091	螺栓GB5783-M12*40EpZn-8.8	BOLT GB5783-M12*40EpZn-8.8	N	4	
14	4015000168	垫圈GB97.1-12EpZn-300HV	WASHER GB97.1-12EpZn-300HV	N	4	
15	4015000026	垫圈GB93-12-65Mn	WASHER GB93-12-65Mn	N	4	
16	29030001021	接头	CONNECTOR	Y	2	
17	4015000203	垫圈JB1002-24-T2	WASHER JB1002-24-T2	N	4	
18	29030012211	下水管	UNDERSIDE COOLANT PIPE	Y	1	
19	29030006531	管夹	CLAMP	Y	1	
20	29030008401	散热器回油胶管	HOSE	Y	1	
21	29030008411	散热器进油胶管	HOSE	Y	1	
22	29030008431	变矩器至散热器油管	OIL TUBE	Y	1	



散热器总成 RADIATOR ASSEMBLY

序号 Key	零件代号 Part No.	名称 Description	是否配件 Spare parts Y/N	数量 Qty	备注 Remarks	
23	29030008421	散热器至变矩器油管	OIL TUBE	Y	1	





**B 变矩器系统**  
**TORQUE CONVERTER SYSTEM**

山东临工工程机械有限公司  
**SHANDONG LINGONG CONSTRUCTION MACHINERY CO.,LTD.**

变矩器总成 TORQUE CONVERTER ASSEMBLY

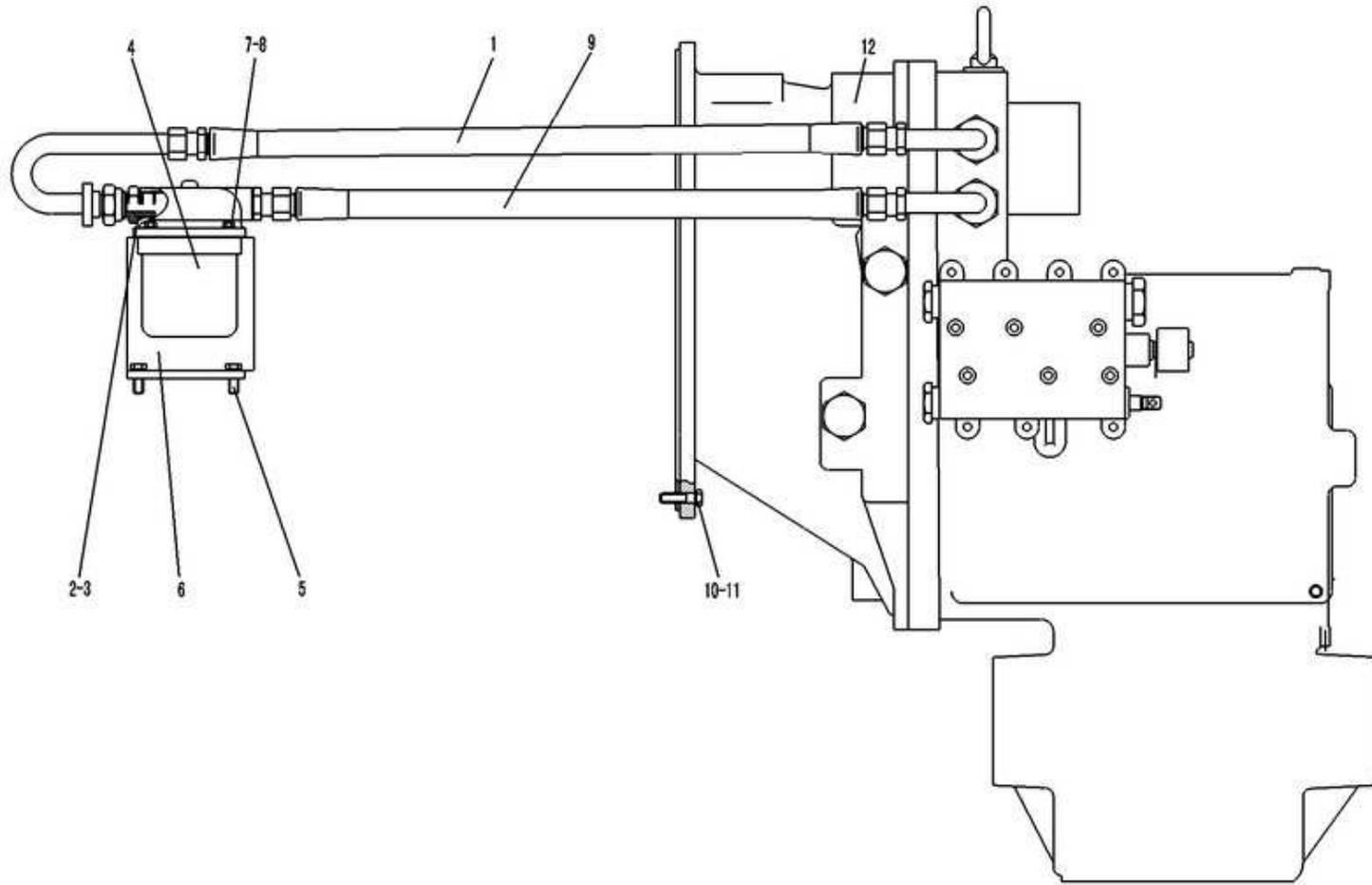

序号 Key	零件代号 Part No.	名称 Description	是否配件 Spare parts Y/N	数量 Qty	备注 Remarks
1	29040008021	变速箱至滤清器油管	TRANSMISSION TO OIL FILTER TUBE	Y	1
2	4120000125	接头体GB3733.2-G28EpZn-35	JOINT BODY GB3733.2-G28EpZn-35	Y	2
3	4030000013	O形圈GB1235-32*3.1	O-RING GB1235-32*3.1	Y	2
4	4110000507	滤清器QF60M33G-1	FILTER QF60M33G-1	Y	1
5	4011000560	螺栓GB16674-M12*25EpZn-8.8	BOLT GB16674-M12*25EpZn-8.8	N	2
6	29040008291	滤清器固定支架	BRACKET	N	1
7	4011000107	螺栓GB5783-M8*30EpZn-8.8	BOLT GB5783-M8*30EpZn-8.8	N	4
8	4015000036	垫圈GB93-8-65Mn	WASHER GB93-8-65Mn	N	4
9	29040007711	滤清器至变速箱油管	OIL TUBE	Y	1
10	4011000091	螺栓GB5783-M12*40EpZn-8.8	BOLT GB5783-M12*40EpZn-8.8	N	12
11	4015000026	垫圈GB93-12-65Mn	WASHER GB93-12-65Mn	N	12
12	4110000841	变矩器YJSW315-6G	TORQUE CONVERTER ASSEMBLY YJSW315-6G	Y	1



变矩器YJSW315-6G

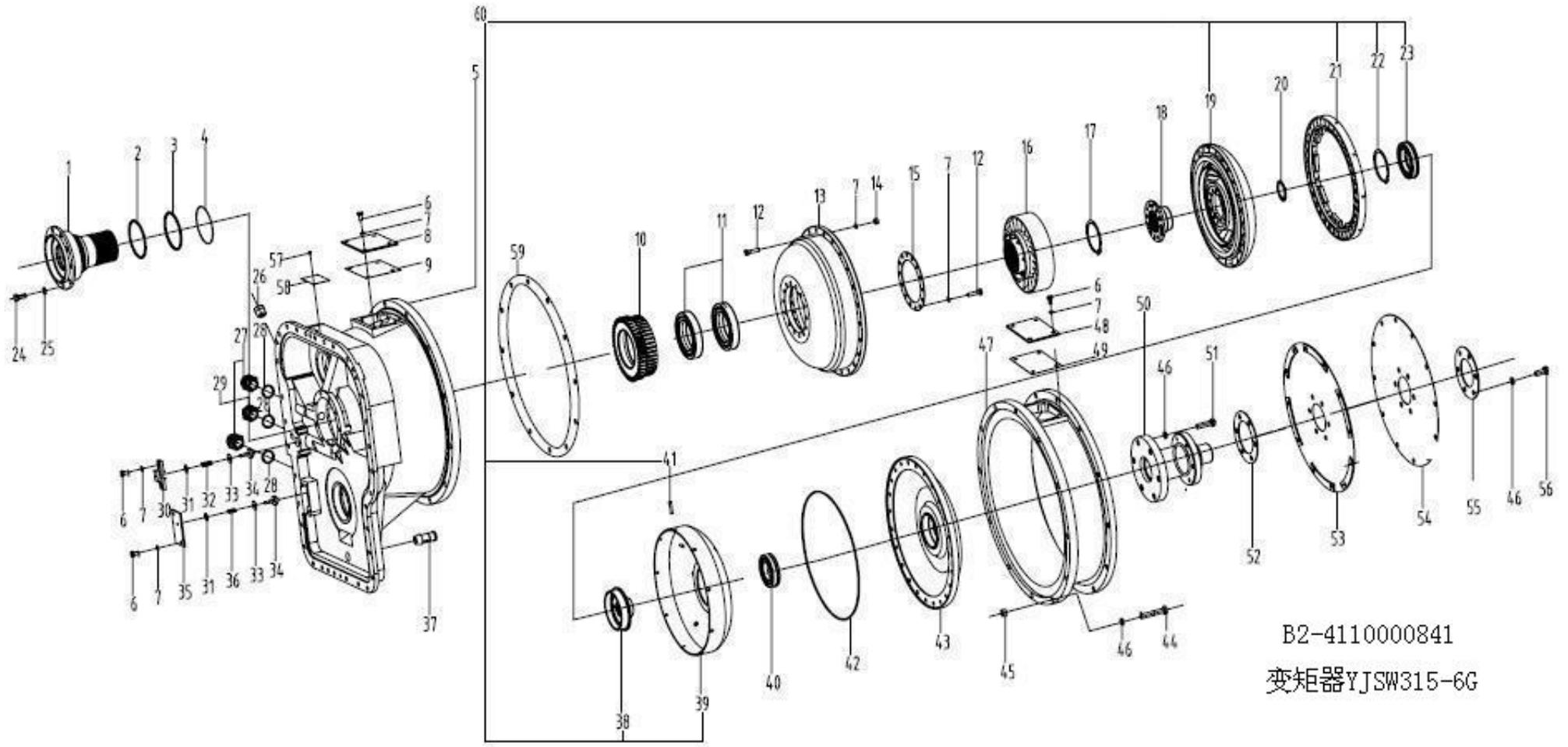

B2-4110000841  
变矩器YJSW315-6G

序号 Key	零件代号 Part No.	名称 Description	是否配件 Spare parts Y/N	数量 Qty	备注 Remarks
1	4110000011081	导轮座YB315Z5-13A	Y	1	
2	4110000011082	密封环YB315Z5-33	Y	1	
3	4110000011083	密封环YB315Z5-12	Y	1	
4	4110000011084	弹性圈YB315Z5-25	Y	1	
5	4110000011085	壳体YB315Z5-08A	Y	1	
6	4110000011086	螺栓M8*16 01010-50816	Y	12	
7	4110000011087	垫圈801602-10825	Y	50	
8	4110000011088	垫板YB315Z5-06A	Y	1	
9	4110000011089	胶垫YB315Z5-07	Y	1	
10	4110000483001	齿轮YJSW315-8A-00004	Y	1	
11	4021000076	滚动轴承GB276-6017	Y	2	
12	4110000160075	螺栓M8*35 01010-60835	Y	38	
13	4110000011092	泵轮YJSW315-6C-00002	Y	1	
14	4110000518002	螺母01580-00806 M8	Y	24	
15	4110000011094	压紧垫片YB315Z5-22A	N	1	
16	4110000011095	导轮YJSW315-6C-00001	Y	1	
17	4110000518004	挡圈04064-08530 85	Y	1	
18	4110000194010	II 涡轮毂YB315Z5.1-2A-2	N	1	
19	4110000194011	II 涡轮YJSW315-6C-11001	N	1	
20	4110000011096	调整垫YB315Z5-30/31/32	Y	1	
21	4110000011123	I 涡轮YJSW315-6C-10001	N	1	
22	4110000011125	挡圈52 YB315Z5.1-5	N	1	

变矩器YJSW315-6G

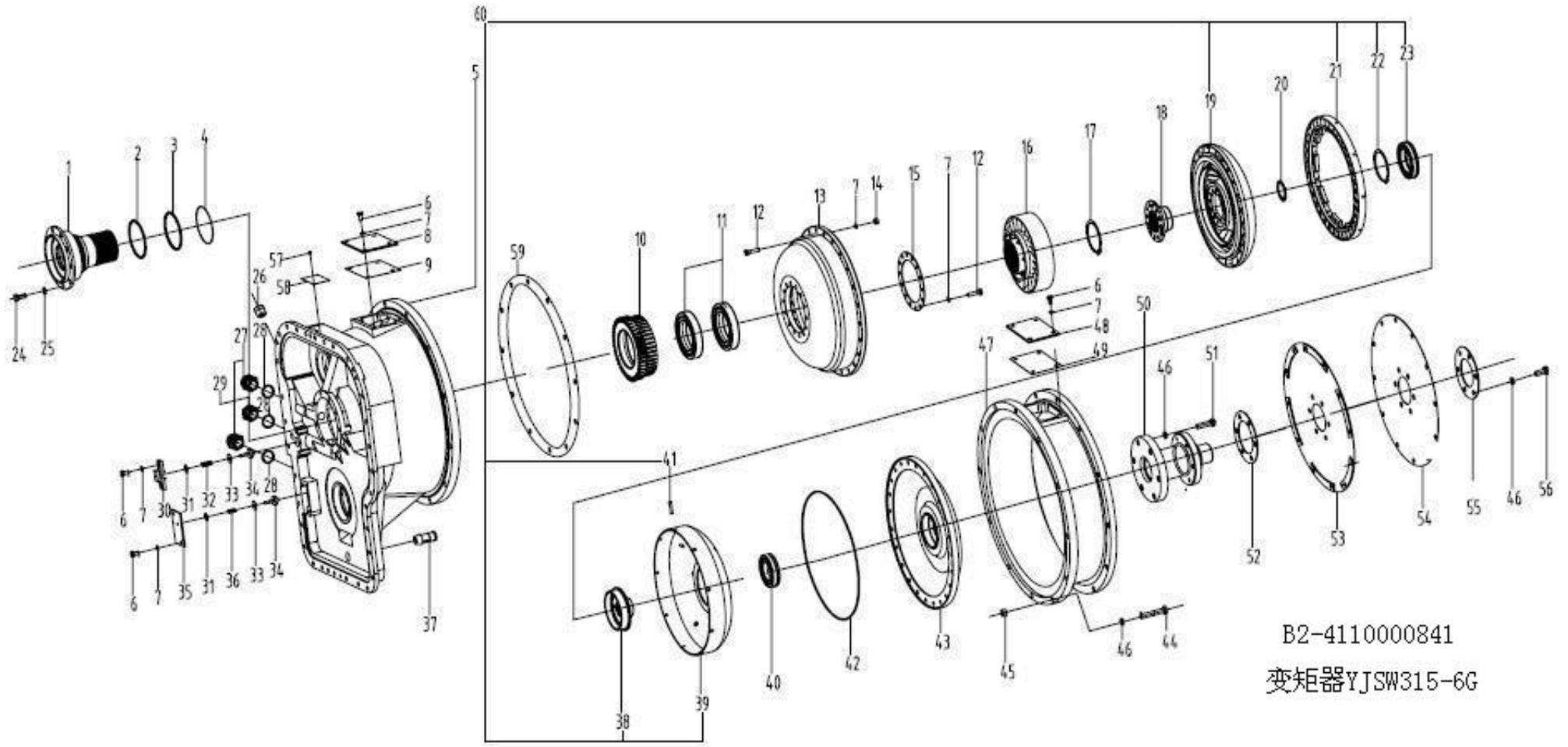

B2-4110000841  
变矩器YJSW315-6G

序号 Key	零件代号 Part No.	名称 Description	是否配件 Spare parts Y/N	数量 Qty	备注 Remarks
23	4021000155	轴承6013	BEARING 6013	N	1
24	4012000022	螺栓GB5783-M10*25-10.9	BOLT GB5783-M10*25-10.9	N	9
25	4110000011097	垫圈10 01602-11030	WASHER 10 01602-11030	Y	9
26	4110000359052	接头1YB315Z5-10L	JOINT 1YB315Z5-10L	Y	1
27	4110000011098	管接头YB315Z5-14L	PIPE JOINT YB315Z5-14L	Y	2
28	4015000209	垫圈JB982-30	WASHER JB982-30	Y	3
29	4110000359015	螺塞1YB315Z5-15L①	PLUG SCREW 1YB315Z5-15L①	Y	1
30	4110000011100	阀盖YB315Z5-17A	VALVE CAP YB315Z5-17A	Y	1
31	4110000011107	调压垫YB315Z5-28.29	ADJUSTING SHIM YB315Z5-28.29	N	1
32	4110000011101	弹簧YB315Z5-18A	SPRING YB315Z5-18A	Y	1
33	4110000011102	调压垫YB315Z5-16.21	ADJUSTING SHIM YB315Z5-16.21	N	1
34	4110000011103	阀杆YB315Z5-26A	VALVE ROD YB315Z5-26A	Y	2
35	4110000011105	压板YB315Z5-19A	PRESS PLATE YB315Z5-19A	N	1
36	4110000011106	弹簧YB315Z5-20	SPRING YB315Z5-20	Y	1
37	4110000011129	管接头YB315Z5-24K	PIPE JOINT YB315Z5-24K	Y	1
38	4110000518010	涡轮毂YJSW315-6C-12001	TURBINE HUB YJSW315-6C-12001	N	1
39	4110000160079	涡轮罩YJSW315-6C-12002	TURBINE CAP YJSW315-6C-12002	N	1
40	4021000018	滚动轴承GB276-6210	BEARING GB276-6210	Y	1
41	4110000011134	销YB315Z5.1-4A	PIN YB315Z5.1-4A	N	9
42	4030000465	PO形圈GB3452.1-355*3.55	O-RING GB3452.1-355*3.55	Y	1
43	4110000194001	罩轮YJSW315-2A-00002	CAP WHEEL YJSW315-2A-00002	Y	1
44	4110000194007	螺栓M12*70-01010-51270	BOLT M12*70-01010-51270	Y	12

变矩器YJSW315-6G

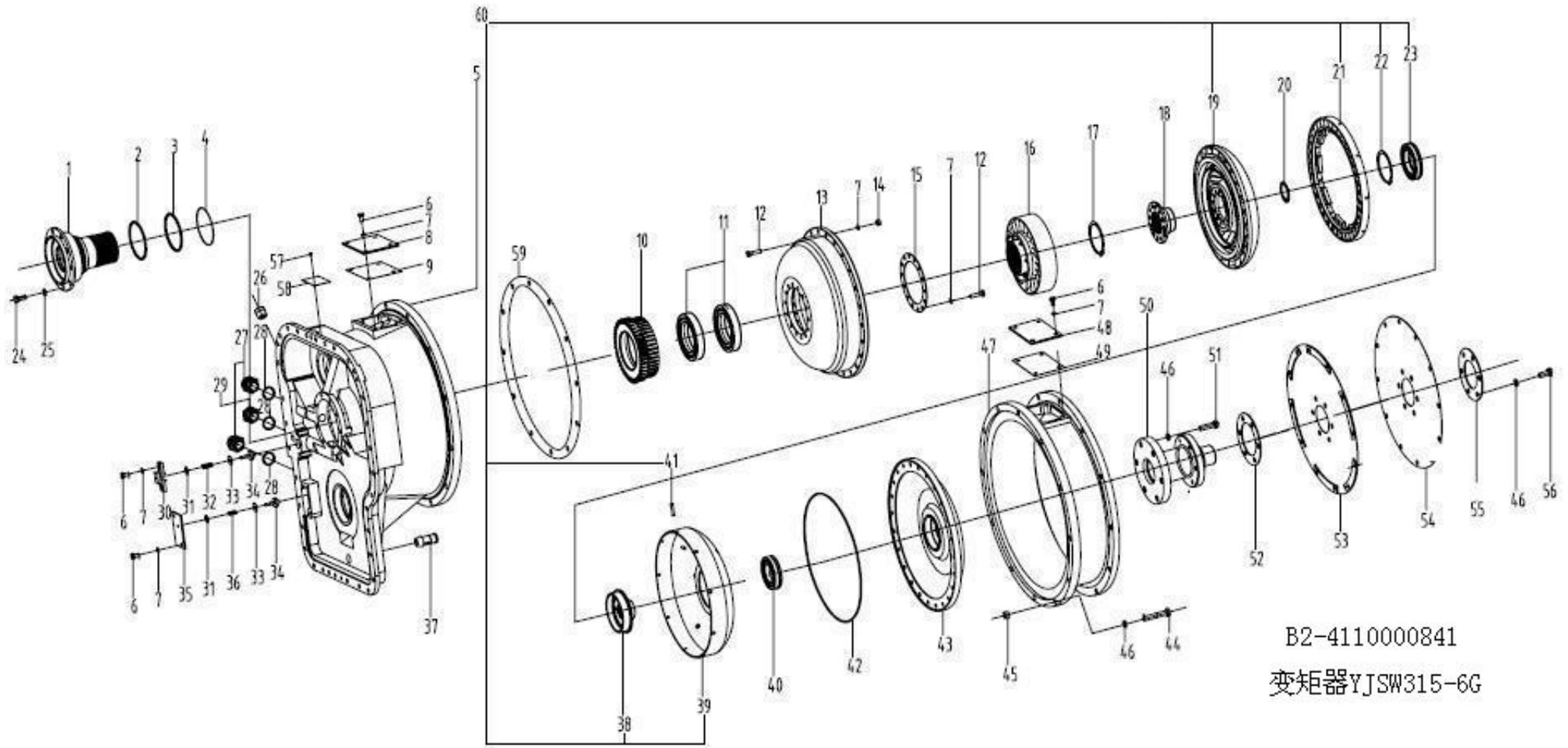

B2-4110000841  
变矩器YJSW315-6G

序号 Key	零件代号 Part No.	名称 Description	是否配件 Spare parts Y/N	数量 Qty	备注 Remarks
45	4110000194006	螺母M12-01580-11210	NUT M12-01580-11210	Y	12
46	4110000011108	垫圈12 01602-11236	WASHER 01602-11236 12	Y	24
47	4110000160056	中节1YJSW315-2A-00001	MEDIUM KNOT 1YJSW315-2A-00001	Y	1
48	4110000194008	盖板YJSW315-2A-00004	COVER PLATE YJSW315-2A-00004	Y	1
49	4110000194009	垫YJSW315-2A-00005	PAD YJSW315-2A-00005	Y	1
50	4110000160059	过渡轴1YJSW315-2A-20000	TRANSITION SHAFT 1YJSW315-2A-20000	Y	1
51	4110000160080	螺栓M12*45 01010-61245	BOLT M12*45 01010-61245	Y	6
52	4110000011113	调整垫YB315Z5-34	ADJUSTING SHIM YB315Z5-34	Y	1
53	4110000011114	弹性板总成YJSW315-20000	ELASTIC PLATE ASSEMBLY YJSW315-20000	Y	1
54	4110000011115	弹性板YJSW315-20001	ELASTIC PLATE	Y	1
55	4110000011116	圆垫板YB315Z5-04	RING PALLET YB315Z5-04	Y	1
56	4110000160081	螺栓M12*30 01010-61230	BOLT M12*30 01010-61230	Y	6
57	7200000846	铆钉3*6 04418-03060	RIVET 3*6 04418-03060	N	4
58	4110000841001	铭牌YJSW315-6G-BP	NAME PLATE YJSW315-6G-BP	N	1
59	4110000011118	衬垫YB315Z5-05	MAT YB315Z5-05	Y	1
60	4110000011111	涡轮组YJSW315-6C-10000	TURBINE GROUP YJSW315-6C-10000	Y	1

滤清器QF60M33G-1 (410708) CLEANER QF60M33G-1 (410708)

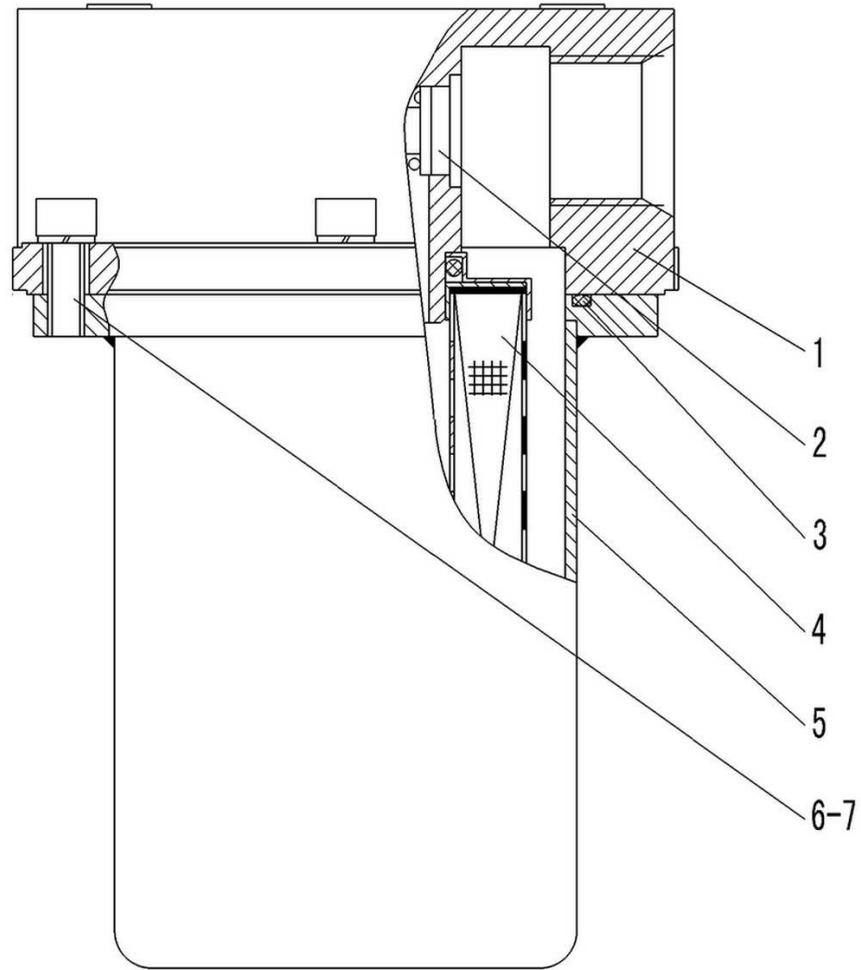

序号 Key	零件代号 Part No.	名称 Description	是否配件 Spare parts Y/N	数量 Qty	备注 Remarks	
1	4110000507002	上壳体PYQ120A-001	UPPER SHELL PYQ120A-001	N	1	
2	4110000507003	旁通阀SFM360-300	VALVE SFM360-300	N	1	
3	4110000507004	胶圈PYQ120A-002W	CUSHION RUBBER PYQ120A-002W	Y	1	
4	4110000508	滤清器滤芯	FILTER CORE	Y	1	
5	4110000507005	下壳体PYQ120A-200	LOWER SHELL PYQ120A-200	N	1	
6	4014000128	螺钉GB70-M8*25EpZn-8.8	SCREW GB70-M8*25EpZn-8.8	N	6	
7	4015000036	垫圈GB93-8-65Mn	WASHER GB93-8-65Mn	N	6	



滤清器QF60M33G-1(371328) CLEANER QF60M33G-1(371328)

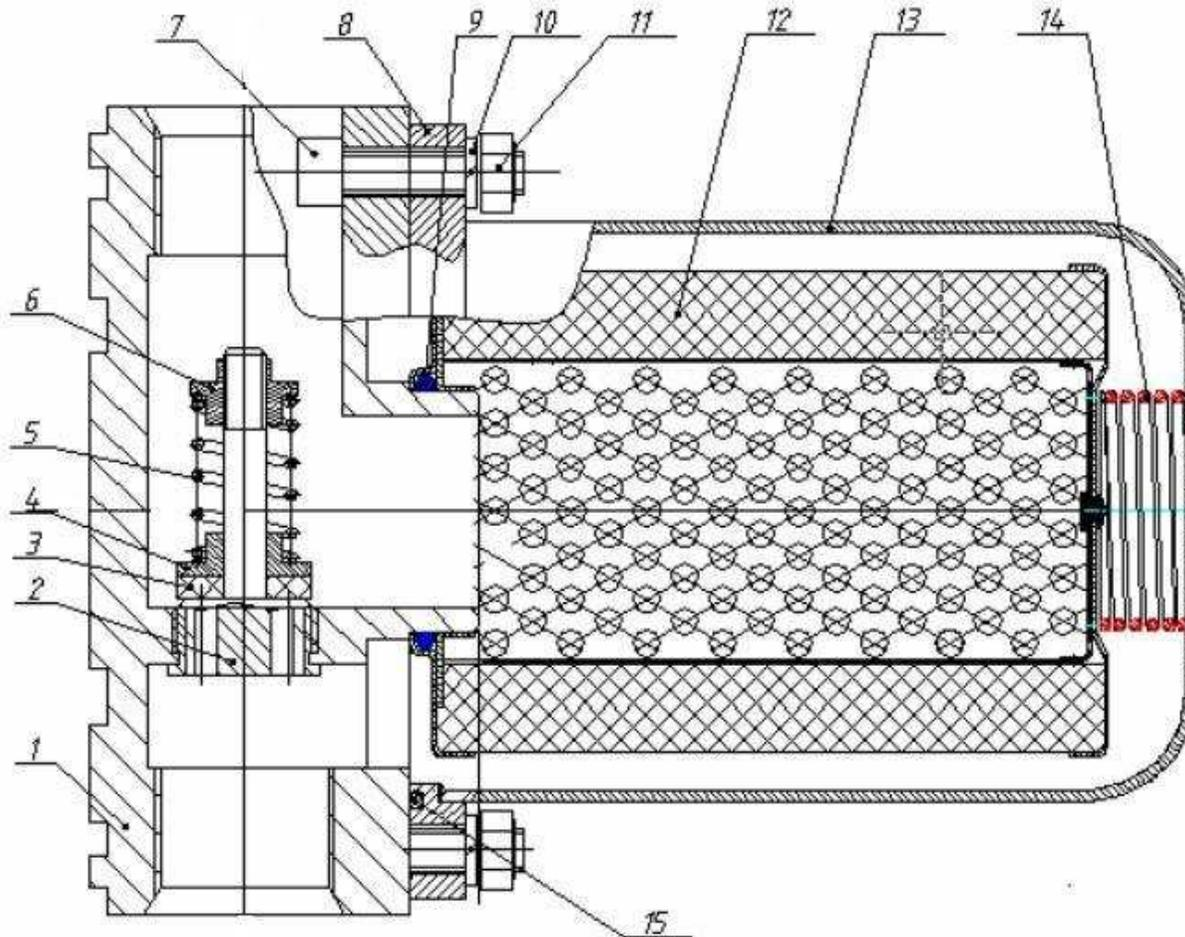

序号 Key	零件代号 Part No.	名称 Description	是否配件 Spare parts Y/N	数量 Qty	备注 Remarks
1	4110000507020	底座JS-LQXX-01	N	1	
2	4110000507021	阀体JS-LQQ-05-05	N	1	
3	4110000507023	密封垫JS-LQQ-05-04	N	1	
4	4110000507024	弹簧支撑JS-LQQ-05-03	N	1	
5	4110000507025	弹簧JS-LQQ-05-02	N	1	
6	4110000507026	压紧螺母JS-LQQ-05-01	N	1	
7	4014000235	螺钉GB2671.2-M8*40EpZn-8.8	N	6	
8	4110000507027	滤清器压板JS-LQXX-04	N	1	
9	4110000507028	O型密封圈44*3.1 JS-LQQ-06	Y	1	
10	4015000036	垫圈GB93-8-65Mn	N	6	
11	4013000033	螺母GB6170-M8EpZn-8	N	6	
12	4110000508	滤清器滤芯	Y	1	
13	4110000507029	外罩JS-LQXX-03	N	1	
14	4110000507030	支撑簧JS-LQXX-08	N	1	
15	4110000507031	密封圈106*3.1 JS-LQXX-07	Y	1	



**C 变速箱系统**  
**TRANSMISSION SYSTEM**

山东临工工程机械有限公司  
**SHANDONG LINGONG CONSTRUCTION MACHINERY CO.,LTD.**

变速箱总成 TRANSMISSION ASSEMBLY

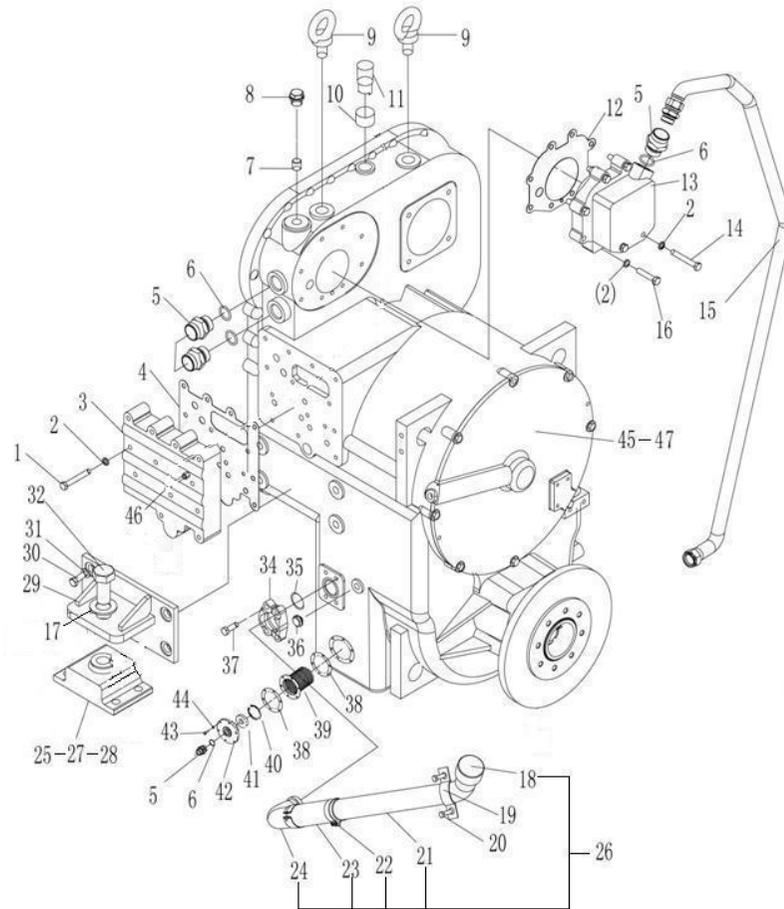

序号 Key	零件代号 Part No.	名称 Description	是否配件 Spare parts Y/N	数量 Qty	备注 Remarks
1	4011000174	螺栓GB21-M10*70EpZn-8.8	N	13	
2	4015000025	垫圈GB93-10-65Mn	N	21	
3	4120000064	变速操纵阀LG03-BSF	Y	1	
4	29050011381	密封垫	Y	1	
5	29050018471	接头体	Y	3	
6	4030000013	O形圈GB1235-32*3.1	Y	3	
7	3030900098	圆柱堵塞	Y	1	
8	4120000345	螺塞Q/ZB286-ZG1/2"-Q235A	Y	2	
9	4014000030	吊环螺钉GB825-M20EpZn-20	N	2	
10	29050000061	透气管	Y	1	
11	29050000051	透气盖总成	Y	1	
12	29050011361	密封垫	Y	1	
13	4120000063	变速泵LG03-BSB	Y	1	
14	4011000052	螺栓GB5782-M10*75EpZn-8.8	N	2	
15	29050000031	变速泵吸油管总成	Y	1	
16	4011000048	螺栓GB5782-M10*50EpZn-8.8	N	6	
17	29050000121	垫圈	Y	1	
18	29050000261	加油管盖	Y	1	
19	29050000091	管夹	Y	1	
20	4011000461	螺栓GB16674-M8*16EpZn-8.8	N	2	
21	3030900208	弯管	Y	1	
22	4120000383	胶管夹箍Q/ZB251-1.5	Y	2	

变速箱总成 TRANSMISSION ASSEMBLY

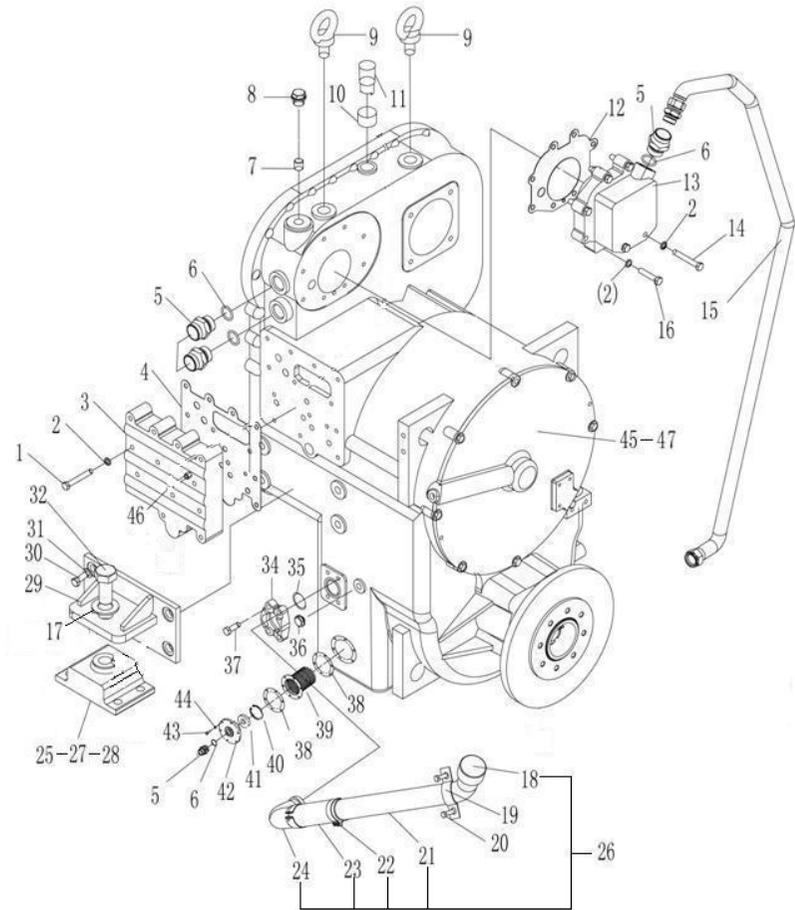

序号 Key	零件代号 Part No.	名称 Description	是否配件 Spare parts Y/N	数量 Qty	备注 Remarks
23	4030000096	胶管JB8406-B38*380	TUBE JB8406-B38*380	Y	1
24	2030900047	加油弯管	PIPE	Y	1
25	4110000460	减震器CBB95-2	SHOCK ABSORBER CBB95-2	Y	1
26	2030900083	加油管	OIL FILLING PIPE	Y	1
27	4013000160	螺母GB889.2-M20*1.5EpZn-8	NUT GB889.2-M20*1.5 EpZn-8	N	1
28	4015000176	垫圈GB97.1-20EpZn-300HV	WASHER GB97.1-20EpZn-300HV	N	1
29	29050000111	连接座	SEAT	Y	1
30	4011000097	螺栓GB5783-M18*40EpZn-8.8	BOLT GB5783-M18*40EpZn-8.8	N	8
31	4015000029	垫圈GB93-18-65Mn	WASHER GB93-18-65Mn	N	8
32	4011000695	螺栓GB5785-M20*1.5*130EpZn-8.8	BOLT	N	1
34	4041000056	分体法兰LGB117-312550	FLANGE LGB117-312550	Y	1
35	4030000029	O形圈GB3452.1-37.5*3.55G	O-RING GB3452.1-37.5*3.55G	Y	1
36	4190000010	检油塞LG03-JYS1/4"	PLUG FOR CHECK UP LG03-JYS1/4"	Y	1
37	4011000475	螺栓GB16674-M10*30EpZn-8.8	BOLT GB16674-M10*30EpZn-8.8	N	4
38	3030900232	垫片	SHIM	Y	2
39	2030900065	滤油器总成	OIL-FILTER ASSEMBLY	Y	1
40	4015000013	挡圈GB893.1-70-65Mn	RETAINER RING GB893.1-70-65Mn	N	1
41	4190000007	环形磁铁LG03-CT70*32*14	RING MAGNET LG03-CT70*32*14	Y	1
42	3030900230	压盖	PRESS COVER	Y	1
43	4011000106	螺栓GB5783-M8*25EpZn-8.8	BOLT GB5783-M8*25EpZn-8.8	N	6
44	4015000036	垫圈GB93-8-65Mn	WASHER GB93-8-65Mn	N	6
45	29050016331	A307A变速箱总成	A307A TRANSMISSION SYSTEM	N	1

变速箱总成 TRANSMISSION ASSEMBLY

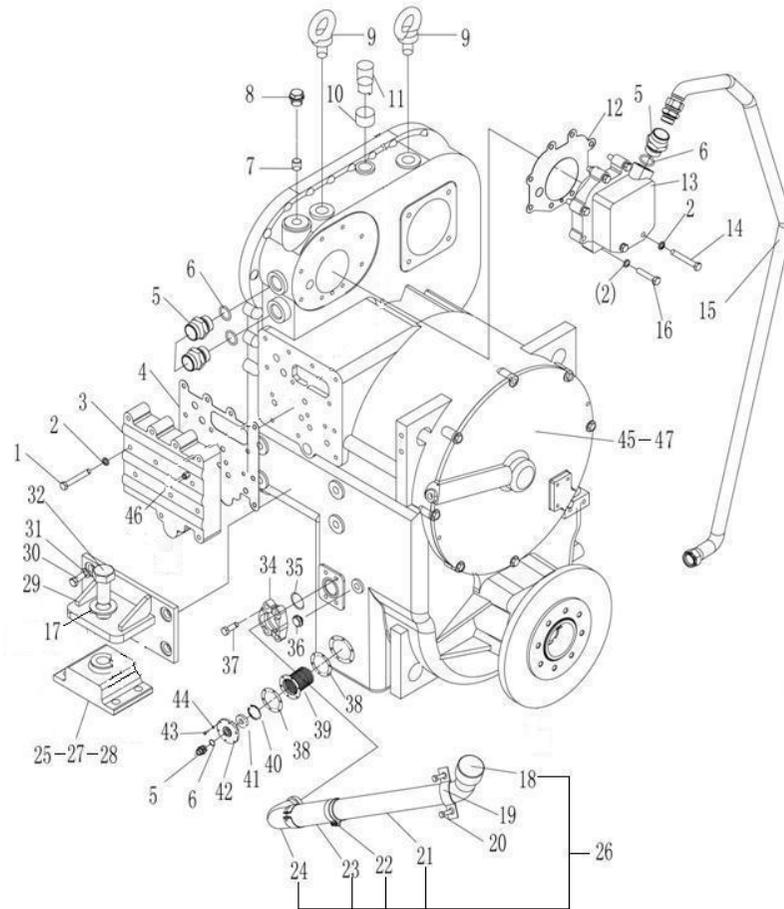

序号 Key	零件代号 Part No.	名称 Description	是否配件 Spare parts Y/N	数量 Qty	备注 Remarks
46	3030900101	压力表接头	Y	1	
47	2190900379	LG946L双变总成	Y	1	





**A307A变速箱总成 A307A TRANSMISSION ASSEMBLE**

序号 Key	零件代号 Part No.	名称 Description	是否配件 Spare parts Y/N	数量 Qty	备注 Remarks
1	4021000012	滚动轴承GB276-6012	BEARING GB276-6012	Y	1
2	29050012701	轴齿轮	GEAR	Y	1
3	4015000024	挡圈GB894.1-90-65Mn	RETAINNER RING GB894.1-90-65Mn	N	2
4	4021000019	滚动轴承GB276-6210N	BEARING GB276-6210N	Y	2
5	29050000071	轴承套	BEARING COVER	Y	1
6	4021000020	滚动轴承GB276-6211	BEARING GB276-6211	Y	1
7	29050000081	驱动轴	DRIVE SHAFT	Y	1
8	4022000001	键GB1096-14*36-45	KEY GB1096-14*36-45	Y	1
9	29050012691	转向泵驱动齿轮	DRIVE GEAR	Y	1
10	2030900027	三轴总成	3RD SHAFT ASS'Y	N	1
11	2030900026	四轴总成(1)	4TH SHAFT ASS'Y ( I )	N	1
12	29050011341	密封垫	SEALING SPACER	Y	1
13	29050011351	密封垫	SEALING SPACER	Y	1
14	29050017921	输出轴总成	OUTPUT SHAFT ASS'Y	Y	1
15	4120000345	螺塞Q/ZB286-ZG1/2"-Q235A	PLUG SCREW Q/ZB286-ZG1/2"-Q235A	Y	1
16	3030900102	螺塞	PLUG SCREW	Y	1
17	3030900090	中盖	COVER	Y	1
18	4015000027	垫圈GB93-14-65Mn	WASHER GB93-14-65Mn	N	8
19	3030900089	中盖螺栓	BOLT	Y	8
20	29050011321	密封垫	SEALING SPACER	Y	1
21	29050011331	密封垫	SEALING SPACER	Y	1
22	29050016561	四轴总成(2)	4TH SHAFT ASSEMBLY(2)	N	1



**A307A变速箱总成 A307A TRANSMISSION ASSEMBLE**

序号 Key	零件代号 Part No.	名称 Description	是否配件 Spare parts Y/N	数量 Qty	备注 Remarks
23	3030900091	端盖 END COVER	Y	1	
24	4015000025	垫圈GB93-10-65Mn WASHER GB93-10-65Mn	N	39	
25	4011000017	螺栓GB21-M10*30EpZn-8.8 BOLT GB21-M10*30EpZn-8.8	N	34	
26	3030900088	箱体 CASE	Y	1	
27	4011000174	螺栓GB21-M10*70EpZn-8.8 BOLT GB21-M10*70EpZn-8.8	N	5	
28	4030000011	O形圈GB1235-20*2.4 O-RING GB1235-20*2.4	Y	1	





三轴总成 3RD SHAFT ASS'Y

序号 Key	零件代号 Part No.	名称 Description	是否配件 Spare parts Y/N	数量 Qty	备注 Remarks
1	4021000013	滚动轴承GB276-6016	Y	1	
2	3030900110	旋转油封	Y	1	
3	3030900178	输入二级齿轮	Y	1	
4	3030900111	旋转油封	Y	1	
5	4021000040	滚动轴承GB301-51111	Y	1	
6	3030900177	输入一级齿轮	Y	1	
7	4021000023	滚动轴承GB276-6311	Y	1	

四轴总成 ( I ) 4TH SHAFT ASS'Y ( I )

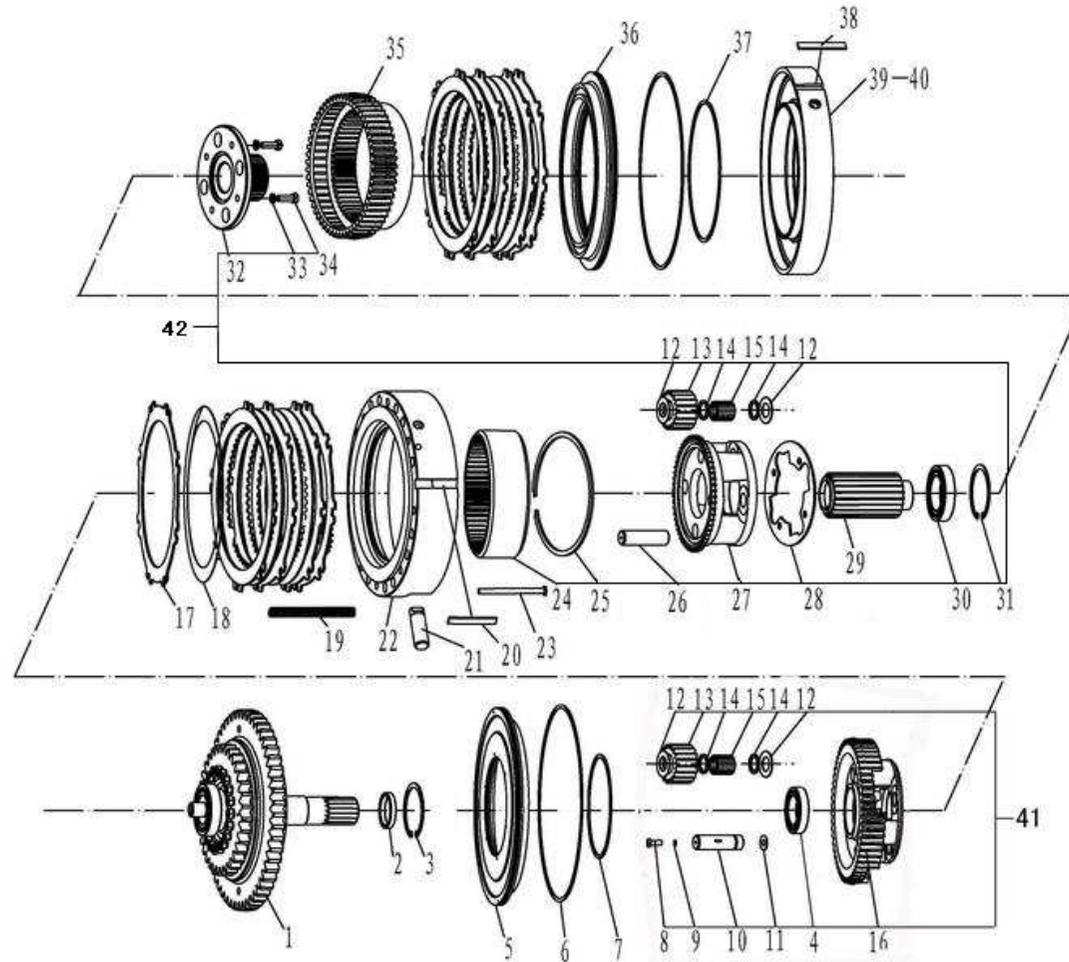

序号 Key	零件代号 Part No.	名称 Description	是否配件 Spare parts Y/N	数量 Qty	备注 Remarks
1	720000462	二轴总成	Y	1	
2	3030900168	间隔套	Y	1	
3	4015000017	挡圈GB893.1-90-65Mn	N	1	
4	4021000011	滚动轴承GB276-6010	Y	2	
5	3030900139	倒档活塞	Y	1	
6	3030900143	外密封环	Y	2	
7	3030900163	内密封环	Y	1	
8	3030900170	螺栓	Y	4	
9	4015000036	垫圈GB93-8-65Mn	N	4	
10	3030900160	倒档行星轴	Y	4	
11	3030900162	止动垫圈	Y	4	
12	3030900147	垫片	Y	16	
13	3030900148	行星轮	Y	8	
14	3030900154	挡圈	Y	16	
15	4090000001	滚针GB309-4*35-GCr15	Y	176	
16	3030900171	倒档行星架	Y	1	
17	3030900140	倒档一档从动片	Y	8	
18	2030900028	倒档一档主动片	Y	8	
19	3030900141	弹簧	Y	15	
20	3030900176	销	Y	8	
21	3030900161	圆柱销	Y	1	
22	2030900029	摩擦片隔离架总成	Y	1	

四轴总成 ( I ) 4TH SHAFT ASS'Y ( I )

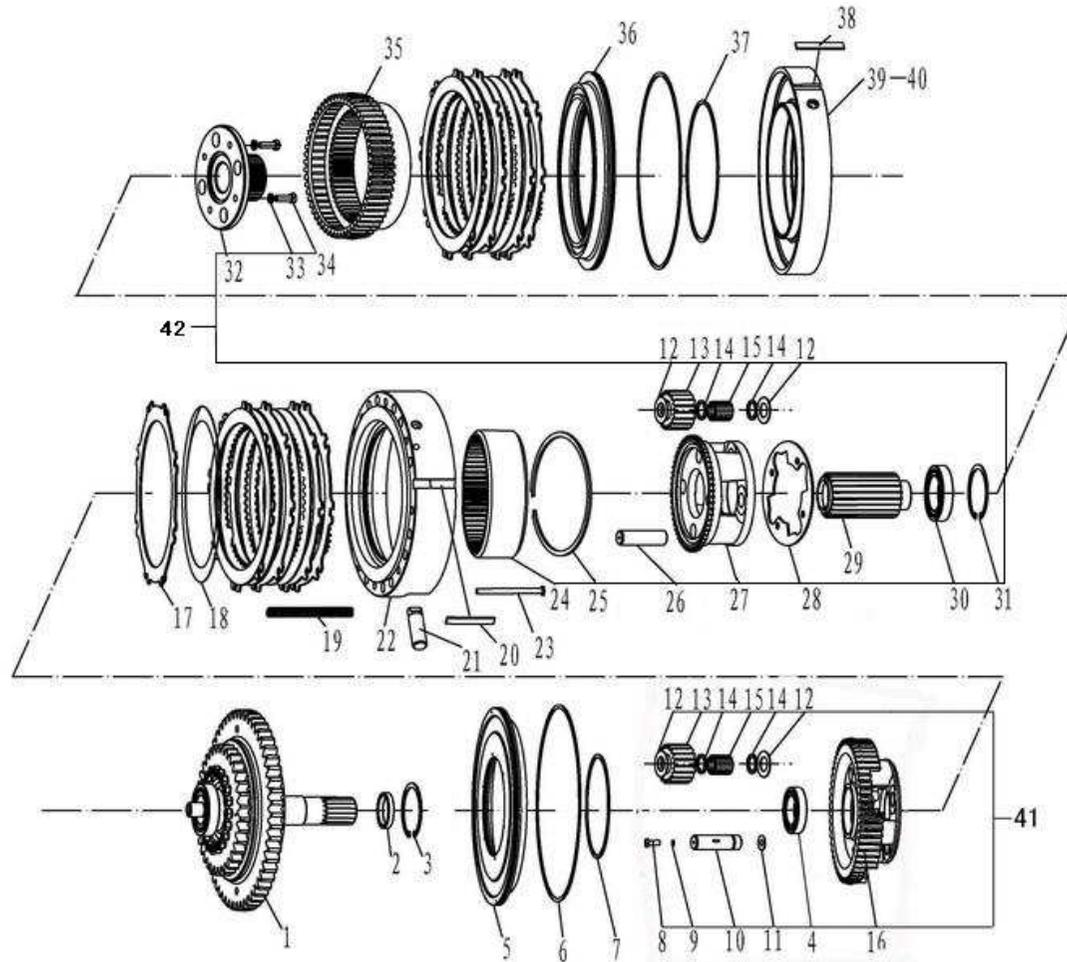

序号 Key	零件代号 Part No.	名称 Description	是否配件 Spare parts Y/N	数量 Qty	备注 Remarks
23	3030900142	弹簧销轴	SPRING PIN	Y	15
24	3030900158	倒档内齿圈	REVERSE RANGE GEAR-RING	Y	1
25	3030900156	挡圈	RIONG SNAP	Y	1
26	3030900149	一档行星轴	FIRST SPEED PLANET SPINDLE	Y	4
27	3030900151	一档行星架	CARRIER OF THE FIRST RANGE PLANET GEAR	Y	1
28	3030900150	止动盘	LOCK PLATE	Y	1
29	3030900153	太阳轮	GEAR-SUN	Y	1
30	4021000019	滚动轴承GB276-6210N	BEARING GB276-6210N	Y	1
31	4015000024	挡圈GB894.1-90-65Mn	RETAINNER RING GB894.1-90-65Mn	N	1
32	3030900152	直接档连接盘	CONNECTING DISH FOR THE DIRECT RANGE	Y	1
33	4015000026	垫圈GB93-12-65Mn	WASHER GB93-12-65Mn	N	4
34	4011000125	螺栓GB5786-M12*1.25*35EpZn-8.8	BOLT GB5786-M12*1.25*35EpZn-8.8	N	4
35	3030900172	内齿圈	INTERNAL GEAR-RING ASSEMBLY FOR FIRST RANGE	Y	1
36	3030900144	一档活塞	FIRST RANGE PISTION	Y	1
37	3030900113	密封环	SEALING RING	Y	1
38	3030900159	固定板	MOUNTING PLATE	Y	1
39	3030900145	一档油缸	CYLINDER-HOUSING FOR THE FIRST RANGE	Y	1
40	3030900146	矩形密封圈	SQUARE SEAL	Y	1
41	7200000115	倒档行星架总成	REVERSING PLANET CARRIER ASSEMBLY	Y	1
42	7200000114	一档行星架总成	ONE STEP PLANET CARRIER ASSEMBLY	Y	1

四轴总成 ( II ) 4TH SHAFT ASS'Y ( II )

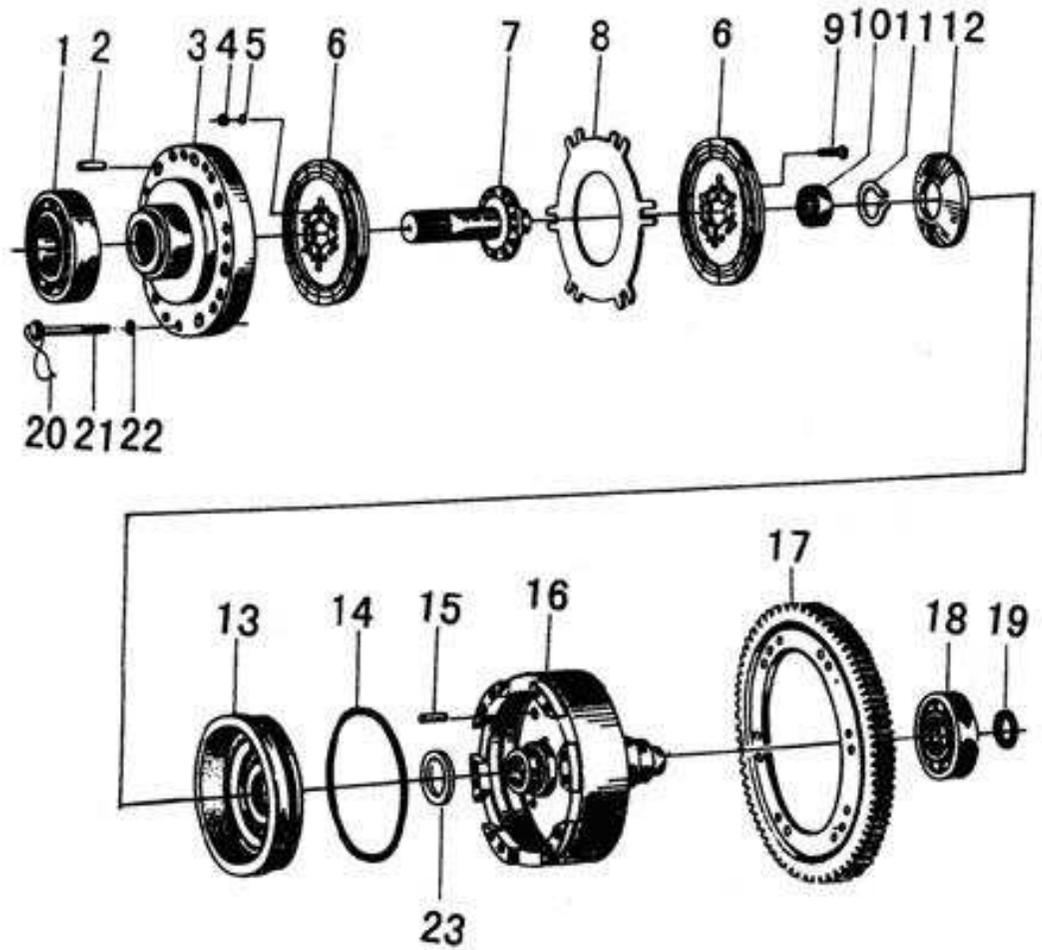

序号 Key	零件代号 Part No.	名称 Description	是否配件 Spare parts Y/N	数量 Qty	备注 Remarks	
1	4021000015	滚动轴承GB276-6022	BALL BEARING GB276-6022	Y	1	
2	3030900112	销	PIN	Y	6	
3	3030900103	直接档受压盘	BACK DISK FOR THE SECOND SPEED	Y	1	
4	4013000162	螺母GB6170-M8-8	NUT GB6170-M8-8	N	12	
5	4015000036	垫圈GB93-8-65Mn	WASHER GB93-8-65Mn	N	12	
6	2030900020	直接档主动片	DRIVE DISK ASS'Y FOR THE SECOND SPEED	Y	2	
7	3030900104	直接档轴	SHAFT FOR THE SECOND SPEED	Y	1	
8	3030900106	直接档从动片	DRIVEN DISK FOR THE SECOND SPEED	Y	1	
9	4011000105	螺栓GB5783-M8*20EpZn-8.8	BOLT GB5783-M8*20EpZn-8.8	N	12	
10	4021000016	滚动轴承GB276-6204	BALL BEARING GB276-6204	Y	1	
11	4015000023	挡圈GB894.1-65-65Mn	RIONG SNAP GB894.1-65-65Mn	N	1	
12	3030900114	碟形弹簧	DISH SPRING	Y	1	
13	3030900107	直接档活塞	PISTION	Y	1	
14	3030900113	密封环	SEALING RING	Y	1	
15	3030900115	销	PIN	Y	3	
16	3030900109	直接档油缸	CYLINDER ASS'Y FOR THE SECOND SPEED	Y	1	
17	29050016321	中间输出齿轮	OUTPUT GEAR OF THE INTER-SHAFT	Y	1	
18	4021000024	滚动轴承GB276-6312	BALL BEARING GB276-6312	Y	1	
19	3030900111	旋转油封	SEAL	Y	1	
20	4090000011	低碳钢丝GB343-1.6*200-SZ	STEEL WIRE GB343-1.2*1200-SZ	Y	1	
21	3030900105	螺栓	BOLT M12X1.25X100	Y	12	
22	4015000026	垫圈GB93-12-65Mn	WASHER GB93-12-65Mn	N	12	

四轴总成 (II) 4TH SHAFT ASS'Y (II)

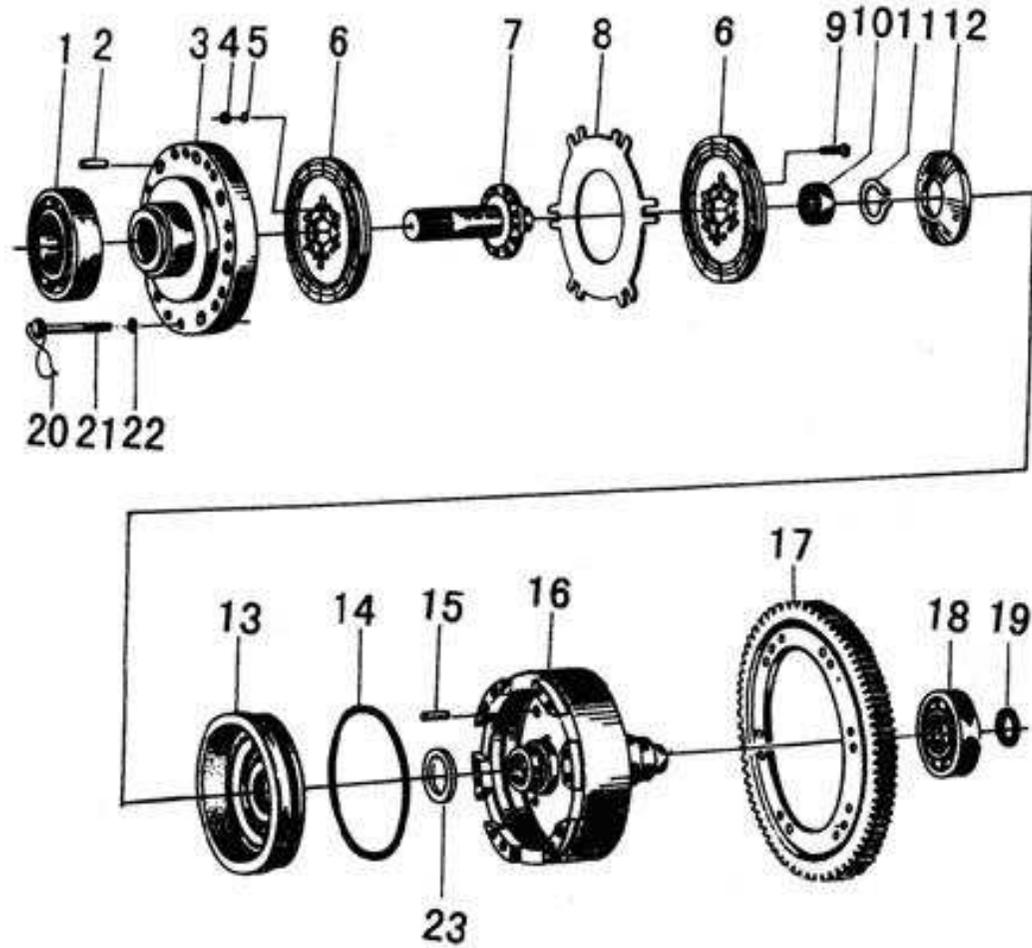

序号 Key	零件代号 Part No.	名称 Description	是否配件 Spare parts Y/N	数量 Qty	备注 Remarks
23	3030900110	旋转油封	Y	1	





**输出轴总成 OUTPUT SHAFT ASSEMBLY**

序号 Key	零件代号 Part No.	名称 Description	是否配件 Spare parts Y/N	数量 Qty	备注 Remarks	
1	4011000084	螺栓GB5783-M10*30EpZn-8.8	BOLT GB5783-M10*30EpZn-8.8	N	2	
2	29050011151	止推垫片	THRUST SPACER	Y	1	
3	29050011161	垫圈	WASHER	Y	1	
4	4030000536	O形圈GB3452.1-122*3.55G	O-RING GB3452.1-122*3.55G	Y	4	
5	29050017481	油封座	OIL SEAL SEAT	Y	2	
6	4021000024	滚动轴承GB276-6312	BALL BEARING GB276-6312	Y	2	
7	29050017461	输出轴	OUTPUT SHAFT	Y	1	
8	29050016311	输出轴齿轮	GAER OF THE OUT SHAFT	Y	1	
9	29050016931	挡圈	CIRCLIP	Y	2	
10	4030000768	密封圈GB13871.1-FB070095-F	SEALING RING GB13871.1-FB070095-F	Y	2	
11	29050017471	密封套	PACKET	Y	2	
12	29050012731	调整垫片	ADJUST SHIM	Y	2	
13	29050012741	调整垫片	ADJUST SHIM	Y	2	
14	29050012751	调整垫片	ADJUST SHIM	Y	2	
15	29070000221	垫圈	WASHER	Y	1	
16	4013000066	螺母GB889.2-M33*1.5-8	NUT GB889.2-M33*1.5-8	N	1	
17	29050018381	O型圈	O-Ring	Y	2	



**D 变速操纵系统**  
**TRANSMISSION CONTROL SYSTEM**

山东临工工程机械有限公司  
**SHANDONG LINGONG CONSTRUCTION MACHINERY CO.,LTD.**

变速操纵系统 TRANSMISSION CONTROL SYSTEM

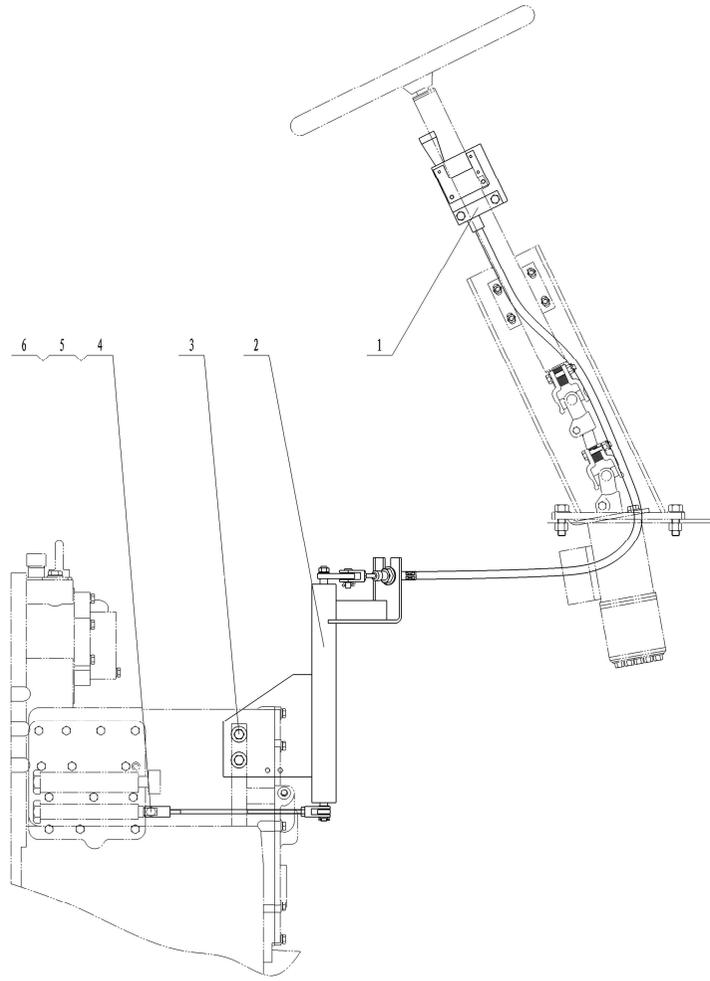

序号 Key	零件代号 Part No.	名称 Description	是否配件 Spare parts Y/N	数量 Qty	备注 Remarks
1	4110000746	变速操纵机构LG936L SPEED CONTROL SETUP LG936L	Y	1	
2	4110000747	变速连杆机构LG936L SPEED CONNECTION SETUP	Y	1	
3	4011000137	螺栓GB16674-M12*20EpZn-8.8 BOLT GB16674-M12*20EpZn-8.8	N	2	
4	4016000143	销轴GB882-B8*26EpZn-35 PIN GB882-B8*26EpZn-35	N	1	
5	4015000072	垫圈GB97.1-8EpZn-300HV WASHER GB97.1-8EpZn-300HV	N	1	
6	4016000183	开口销GB91-3.2*22EpZn-Q235A PIN GB91-3.2*22EpZn-Q235A	N	1	



变速操纵机构LG936L TRANSMISSION CONTROL INSTITUTION LG936L

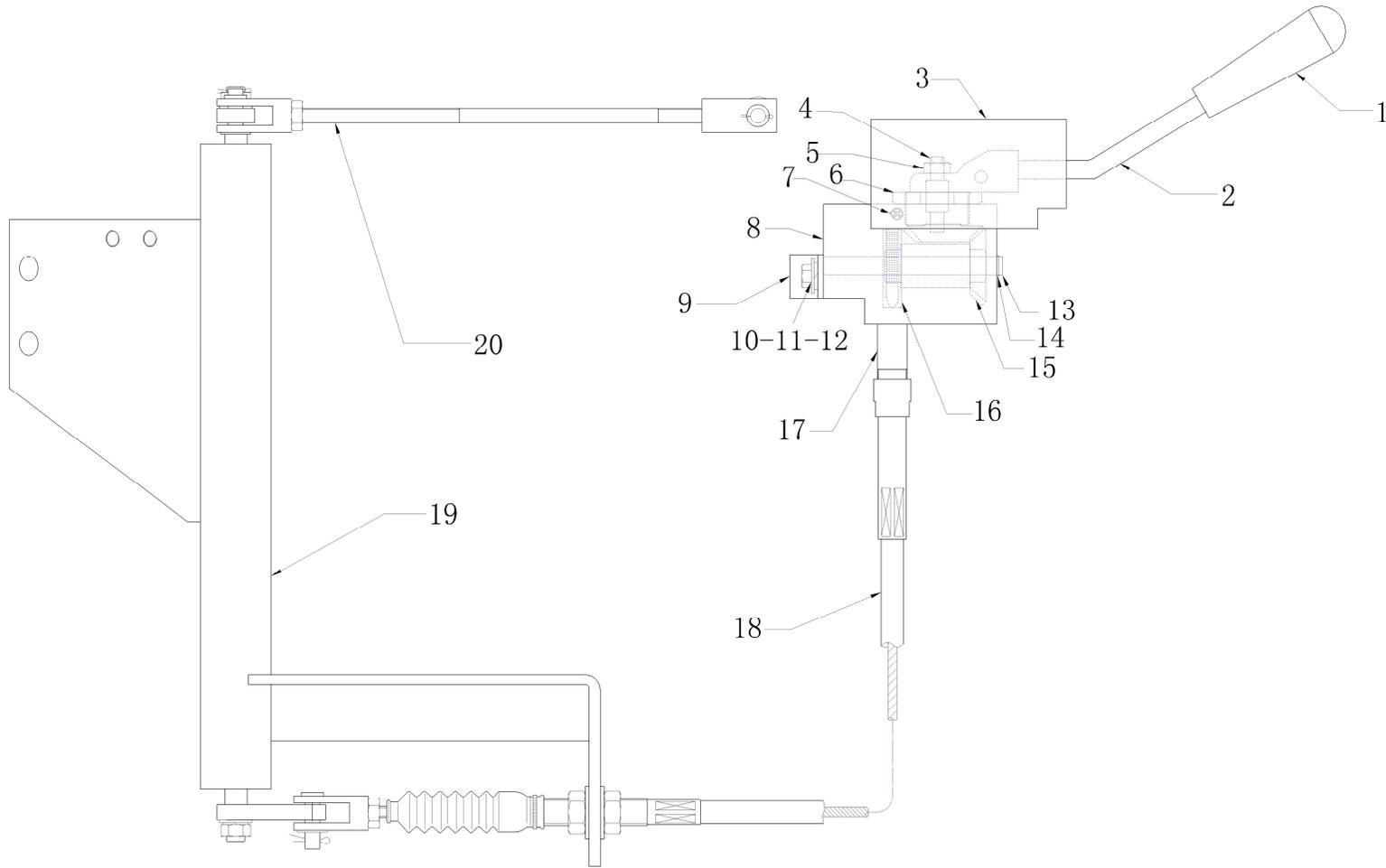

序号 Key	零件代号 Part No.	名称 Description	是否配件 Spare parts Y/N	数量 Qty	备注 Remarks	
1	4110000172006	手球LGHD9530001	HAND BALL LGHD9530001	Y	1	
2	4110000172007	手柄组件LGHD9530002	HANDLE PARTS LGHD9530002	Y	1	
3	4110000172008	盒罩LGHD9530003	COVER LGHD9530003	Y	1	
4	4110000172025	轴组件LGHD9530004	BUSHING LGHD9530004	Y	1	
5	4110000172010	螺母LGHD9530005 M10	NUT LGHD9530005 M10	N	1	
6	4110000172011	螺母LGHD9530006 M36	NUT LGHD9530006 M36	Y	1	
7	4110000172012	螺母LGHD9530007 M5	NUT LGHD9530007 M5	N	3	
8	4110000172013	换挡盒LGHD9530008	BOX LGHD9530008	Y	1	
9	4110000172009	固定板LG953HD0009	MOUNTED PLATE	Y	1	
10	4110000172015	螺栓LGHD9530010 M8	BOLT LGHD9530010 M8	N	2	
11	4110000172016	螺母LGHD9530011 M8	NUT LGHD9530011 M8	N	2	
12	4110000172017	弹垫LGHD9530012	WASHER LGHD9530012	N	2	
13	4110000172018	销轴LGHD9530013	PIN LGHD9530013	Y	1	
14	4110000172019	卡簧LGHD9530014	CIRCLIP LGHD9530014	N	1	
15	4110000172020	齿轮套组件LGHD9530015	GEARED SLEEVE PARTS LGHD9530015	Y	1	
16	4110000172021	齿条LGHD9530016	RACK LGHD9530016	Y	1	
17	4110000172022	齿条筒LGHD9530017	RACK CANISTER LGHD9530017	Y	1	
18	4110000746001	软轴总成LGHD9360001	FLEXIBLE ASSEMBLY LGHD9360001	Y	1	
19	4110000746002	软轴支架LGHD9360002	FLEXIBLE BRACKET LGHD9360002	Y	1	
20	4110000659001	连接杆LGHD9560004	CONNECTING LINK LGHD9560004	Y	1	

变速操纵阀LG03-BSF(350802) TRANSMISSION CONTROL LG03-BSF VALVE(350802)

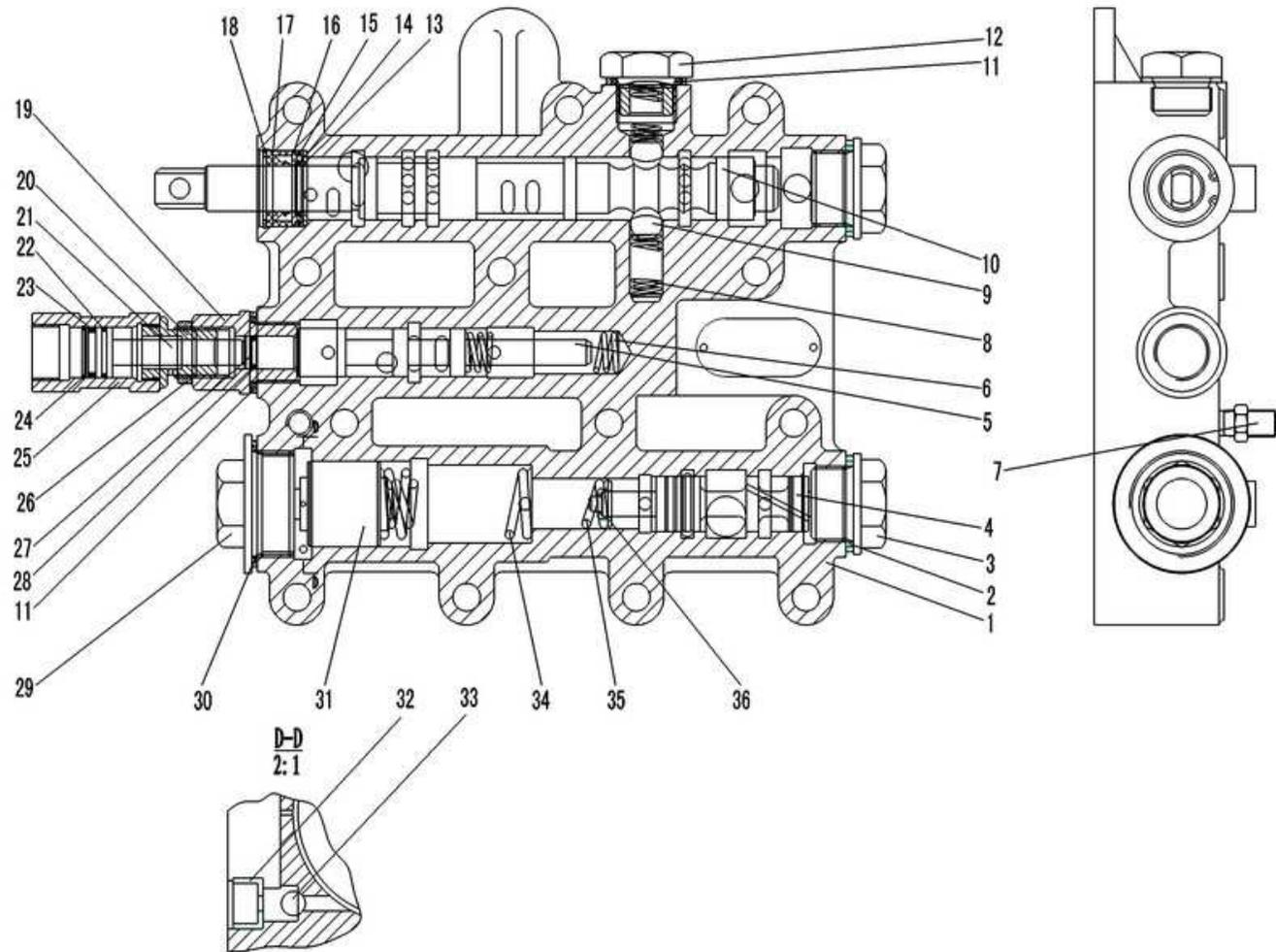

序号 Key	零件代号 Part No.	名称 Description	是否配件 Spare parts Y/N	数量 Qty	备注 Remarks
1	412000064005	阀体ZL30.05.17-1	N	1	
2	4015000209	垫圈JB982-30	Y	2	
3	412000064003	螺栓ZL30.05.17-2	N	2	
4	412000064007	减压阀杆ZL30.05.17-4	N	1	
5	412000064013	刹车阀杆ZL30.05.17-5a	N	1	
6	412000064002	刹车弹簧ZL30.05.17-6	Y	1	
7	412000064006	压力表接头403727-A	Y	1	
8	412000064028	弹簧ZL30.05.17-7	N	2	
9	4090000120	钢球GB308-12.7-GCr15	N	2	
10	412000064024	分配阀杆ZL30.05.17-8	N	1	
11	4015000122	垫圈JB982-24	N	1	
12	412000064031	螺栓ZL30.05.17-10	N	1	
13	412000064034	垫圈ZL30.05.17-11/2	N	1	
14	4030000012	O形圈GB1235-22*2.4	Y	1	
15	4030000731	O形圈GB1235-30*2.4	Y	1	
16	412000064025	挡套ZL30.05.17-11	N	1	
17	412000064026	骨架油封18*30*10 HG4-692-67	Y	1	
18	4015000283	挡圈GB893.1-30-65Mn	N	1	
19	412000064017	螺栓ZL30.05.17-19	N	1	
20	412000064035	气阀座ZL30.05.17-12A	N	1	
21	412000064036	气阀杆ZL30.05.17-13B	N	1	
22	4030000268	O形圈GB3452.1-17.0*1.80G	Y	1	

变速操纵阀LG03-BSF(350802) TRANSMISSION CONTROL LG03-BSF VALVE(350802)

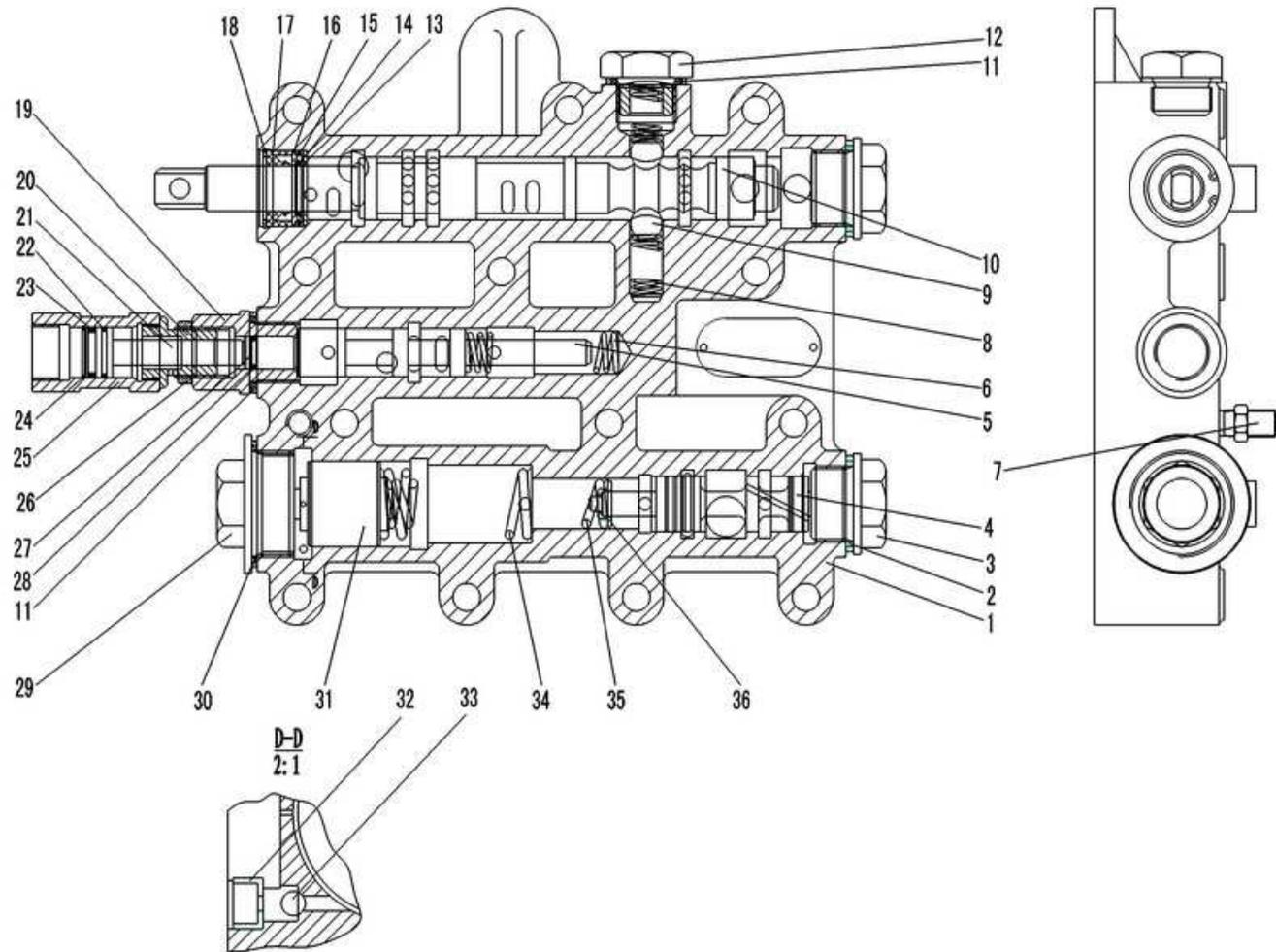

序号 Key	零件代号 Part No.	名称 Description	是否配件 Spare parts Y/N	数量 Qty	备注 Remarks
23	4030000011	O形圈GB1235-20*2.4	O-RING GB1235-20*2.4	Y	1
24	4015000308	挡圈GB893.1-20-65Mn	RETAINER GB893.1-20-65Mn	N	1
25	4120000064037	气阀体ZL50.6.18-16a/1	VALVE BODY ZL50.6.18-16a/1	N	1
26	4120000064018	螺母ZL25.1-09A	NUT ZL25.1-09A	N	1
27	4120000064014	圆柱塞ZL30.05.17-18	ROUND PLUG ZL30.05.17-18	N	1
28	4030000634	O形圈GB1235-13*1.9	O-RING GB1235-13*1.9	N	1
29	4120000064001	螺栓Φ55*31 ZL30.05.17-20	BOLT Φ55*31 ZL30.05.17-20	Y	1
30	4015000307	垫圈JB982-42	WASHER JB982-42	N	1
31	4120000064011	滑块ZL30.05.17-22	SLIDE BLOCK ZL30.05.17-22	N	1
32	4120000064033	圆板ZL30.05.17-26	CIRCULAR FLAT-PLATE ZL30.05.17-26	N	1
33	4090000154	钢球GB308-4.762-GCr15	STEEL BALL GB308-4.762-GCr15	N	1
34	4120000064010	弹簧ZL30.05.17-23	SPRING ZL30.05.17-23	Y	1
35	4120000064009	弹簧ZL30.05.17-24B	SPRING ZL30.05.17-24B	Y	1
36	4120000064008	弹簧座ZL30.05.17-25	SPRING SEAT ZL30.05.17-25	N	1



**E 驱动桥系统**  
**AXLE SYSTEM**

山东临工工程机械有限公司  
**SHANDONG LINGONG CONSTRUCTION MACHINERY CO.,LTD.**

前桥总成 FRONT AXLE ASSEMBLY

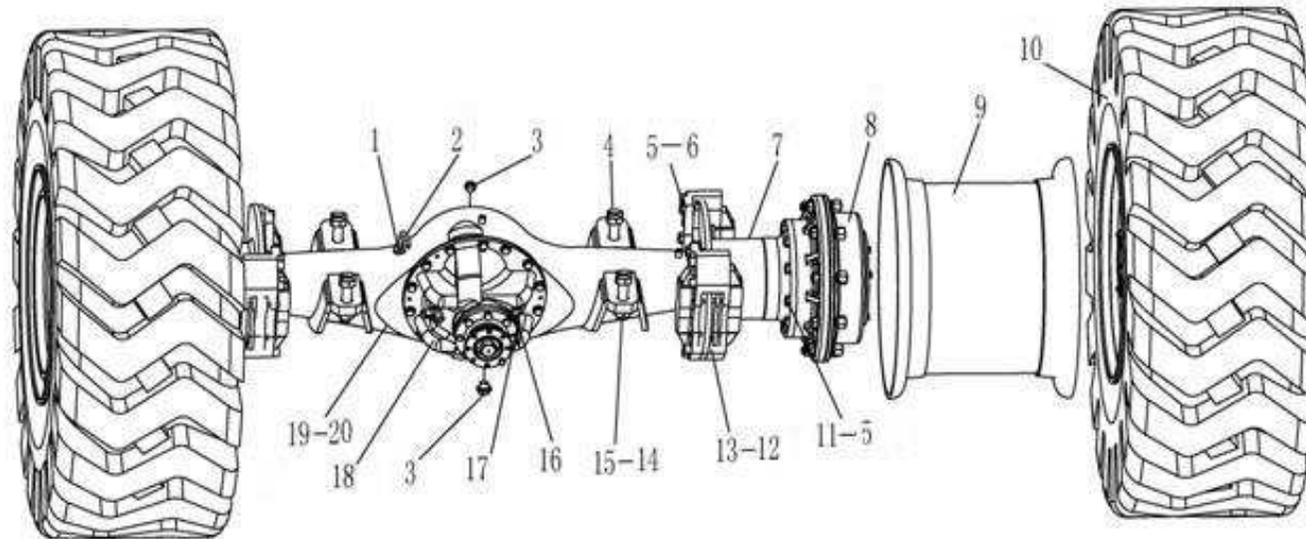

序号 Key	零件代号 Part No.	名称 Description	是否配件 Spare parts Y/N	数量 Qty	备注 Remarks
1	4013000078	螺母GB6173-M10*1EpZn-05	N	1	
2	29070000051	透气管	Y	1	
3	29070012481	磁性螺塞	Y	2	
4	4011000915	螺栓GB5785-M30*2*140EpZn-8.8	N	8	
5	4015000030	垫圈GB93-20-65Mn	N	36	
6	29070000101	螺栓	Y	16	
7	3090900009	制动盘	Y	2	
8	29070009271	轮边减速器	Y	1	
9	4190000414	轮辋	Y	2	
10	4110000005	轮胎GB2980-20.5-25	Y	2	
11	4011000130	螺栓GB5786-M20*1.5*50EpZn-8.8	N	20	
12	4120001739	制动钳	Y	1	
13	4120001740	放气嘴	Y	8	
14	4015000032	垫圈GB93-30-65Mn	N	8	
15	4013000064	螺母GB889.2-M30*2EpZn-8	N	8	
16	4044000081	标牌LGB402-D/A504	Y	1	
17	4019000012	铆钉GB827-3*5-BL2	N	4	
18	29070001061	前主传动	Y	1	
19	29070009251	前桥壳总成	Y	1	
20	29070009241	A504前驱动桥总成	Y	1	

前主传动总成 FRONT AXLE MAIN DRIVE ASSEMBLY

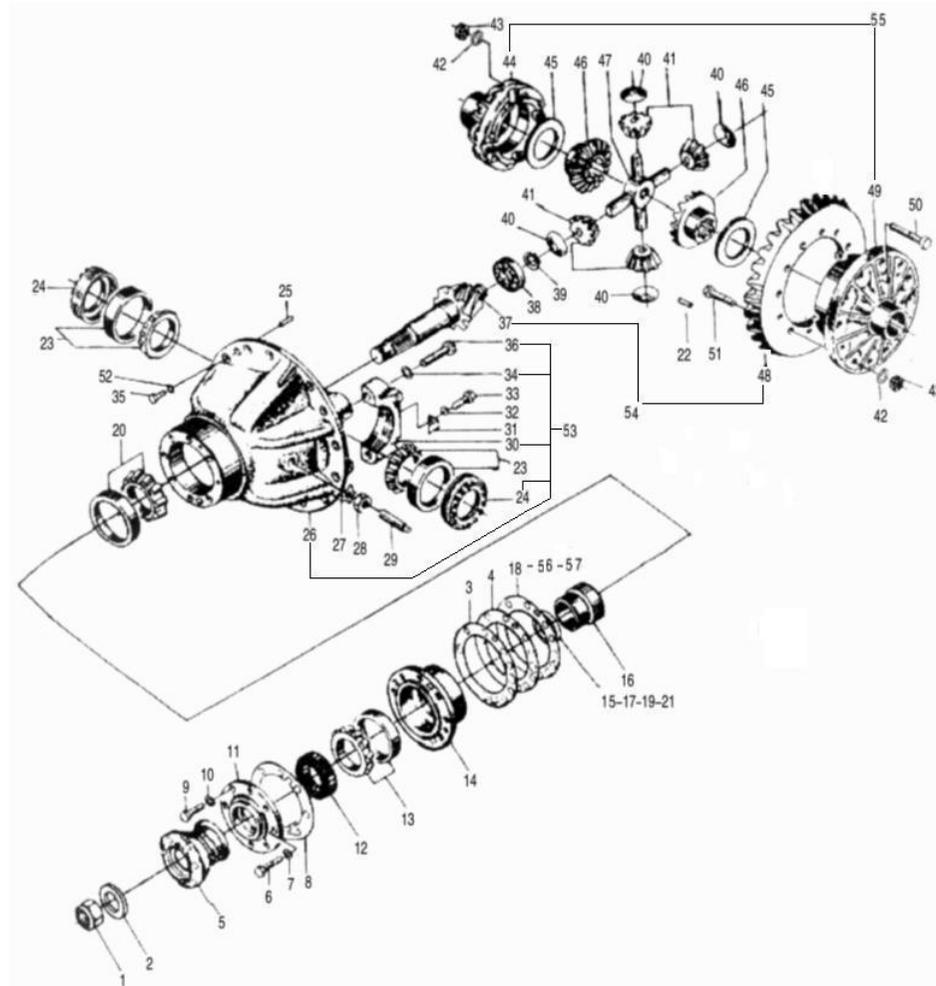

序号 Key	零件代号 Part No.	名称 Description	是否配件 Spare parts Y/N	数量 Qty	备注 Remarks
1	4013000066	螺母GB889.2-M33*1.5-8	N	1	
2	29070001121	垫圈	Y	1	
3	29070001181	调整垫片	Y	3	
4	29070001191	调整垫片	Y	4	
5	29070001131	输入法兰	Y	1	
6	4011000067	螺栓GB5782-M14*55EpZn-8.8	N	7	
7	4015000027	垫圈GB93-14-65Mn	N	7	
8	29070001161	垫密片	Y	1	
9	4011000186	螺栓GB5782-M12*55EpZn-8.8	N	1	
10	4015000026	垫圈GB93-12-65Mn	N	1	
11	29070001141	密封盖	Y	1	
12	4030000049	油封HG4-692-SG80*100*12	Y	1	
13	4021000030	滚动轴承GB297-31313	Y	1	
14	29070001171	轴承套	Y	1	
15	29070000181	垫片	Y	2	
16	29070001151	轴套	Y	1	
17	29070000191	垫片	Y	2	
18	29070001201	调整垫片	Y	5	
19	29070000201	垫片	Y	3	
20	4021000032	滚动轴承GB297-31314	Y	1	
21	29070000211	垫片	Y	3	
22	29070000461	固定销	Y	4	

前主传动总成 FRONT AXLE MAIN DRIVE ASSEMBLY

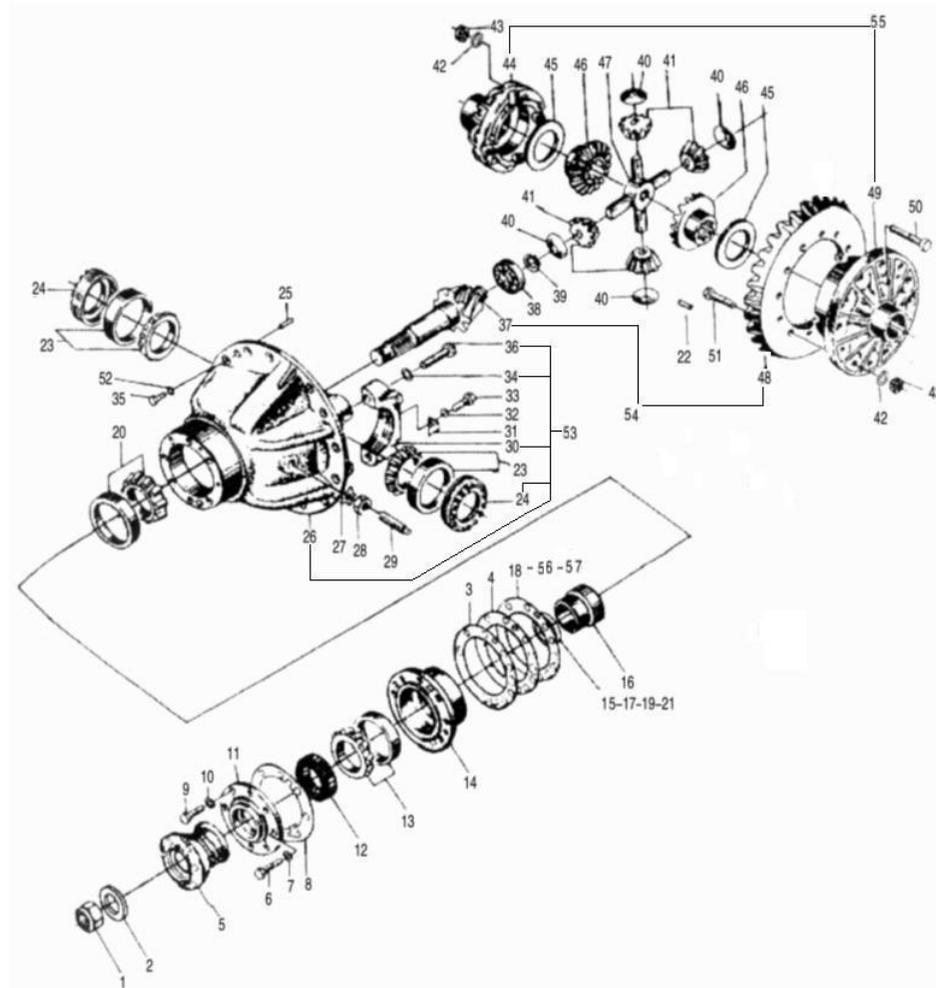

序号 Key	零件代号 Part No.	名称 Description	是否配件 Spare parts Y/N	数量 Qty	备注 Remarks
23	4021000036	滚动轴承GB297-32216	BEARING GB297-32216	Y	2
24	29070000351	调整螺母	ADJUSTING NUT	Y	2
25	4016000124	销GB119.2-10u8*30	PIN GB119.2-10u8*30	N	2
26	29070001221	托架	CARRIER	N	1
27	29070000311	锁紧片	LOCKING LEAF	Y	1
28	4013000052	螺母GB6173-M27*2-05	NUT GB6173-M27*2-05	N	1
29	29070000301	止推螺栓	BOLT	Y	1
30	29070000391	轴承座	CAGE	N	2
31	29070000401	锁紧片	LOCKING LEAF	Y	2
32	4015000025	垫圈GB93-10-65Mn	WASHER GB93-10-65Mn	N	2
33	4011000597	螺栓GB5786-M10*1*20EpZn-8.8	BOLT GB5786-M10*1*20EpZn-8.8	N	2
34	29070001301	垫圈	WASHER	Y	4
35	4011000126	螺栓GB5786-M16*1.5*40EpZn-8.8	BOLT GB5786-M16*1.5*40EpZn-8.8	N	14
36	29070009521	螺栓	BOLT	Y	4
37	29070001211	主动螺旋伞齿轮（左）	SPIRAL BEVEL GEAR PINION(LEFT)	N	1
38	4021000027	滚动轴承GB283-NUP2307	BEARING GB283-NUP2307	Y	1
39	4015000020	挡圈GB894.1-35-65Mn	RETAINER RING GB894.1-35-65Mn	N	1
40	29070000331	锥齿轮垫片	WASHER THRUST	Y	4
41	29070000341	锥齿轮	GEAR PINION	Y	4
42	29070009511	垫圈	WASHER	Y	20
43	4013000198	螺母GB6176-M16*1.5-10	NUT GB6176-M16*1.5-10	N	20
44	29070000431	差速器左壳	LEFT CASE DIFFERENTIAL MECHANISM	N	1

前主传动总成 FRONT AXLE MAIN DRIVE ASSEMBLY

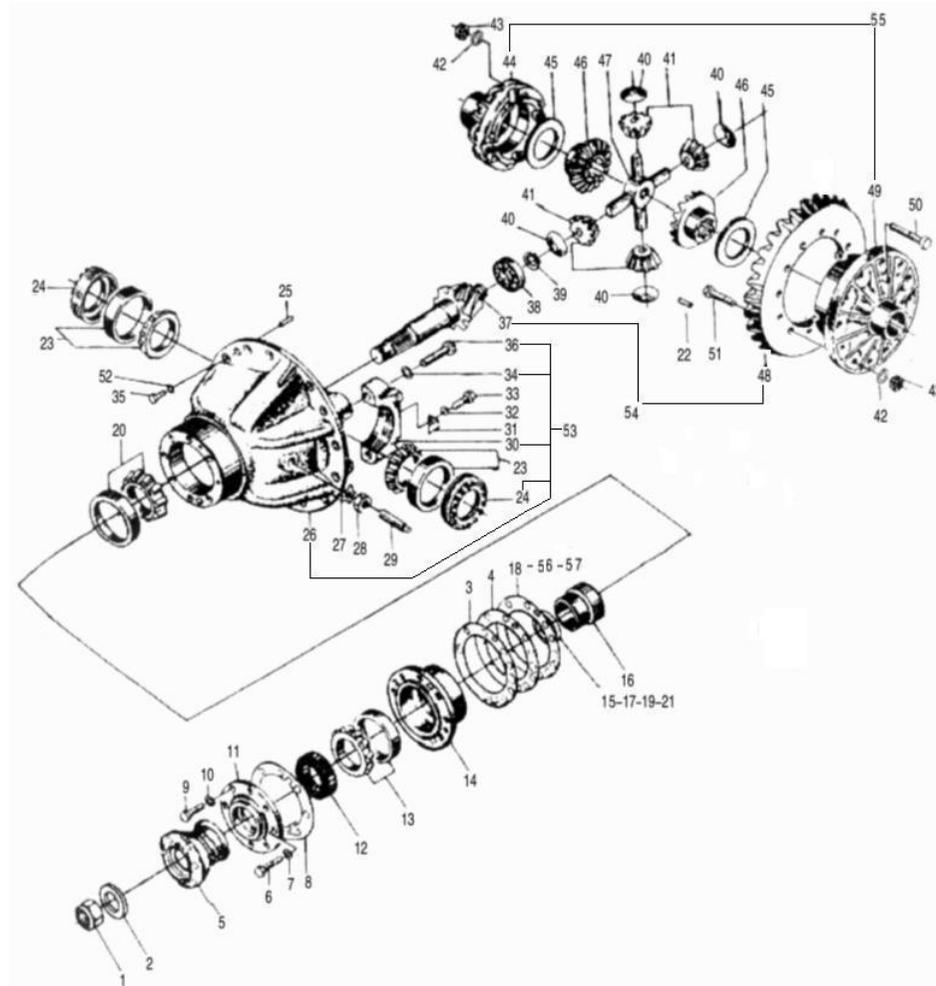

序号 Key	零件代号 Part No.	名称 Description	是否配件 Spare parts Y/N	数量 Qty	备注 Remarks
45	29070000381	半轴齿轮垫片	Y	2	
46	29070000371	半轴齿轮	Y	2	
47	29070000411	十字轴	Y	1	
48	29070000451	从动螺旋伞齿轮（右）	N	1	
49	29070000361	差速器右壳	N	1	
50	29070009491	螺栓	Y	8	
51	29070009501	螺栓	Y	12	
52	4015000098	垫圈GB93-16-65Mn	N	14	
53	29070001321	托架总成	Y	1	
54	2050900103	主动螺旋伞齿轮(左)	Y	1	
55	2050900079	差速器左右壳	Y	1	
56	29070013031	调整垫片	Y	2	
57	29070013041	调整垫片	Y	2	



**传动轴总成 DRIVE SHAFT ASSEMBLY**

序号 Key	零件代号 Part No.	名称 Description	是否配件 Spare parts Y/N	数量 Qty	备注 Remarks	
1	4011000568	螺栓GB5786-M12*1.25*40EpZn-10.9	BOLT GB5786-M12*1.25*40EpZn-10.9	N	24	
2	4013000072	螺母GB889.2-M12*1.25EpZn-10	NUT GB889.2-M12*1.25EpZn-10	N	32	
3	4110000844	后传动轴CDZP-372	REAR TRANSMISSION SHAFT CDZP-372	Y	1	
4	29080001031	螺栓	BOLT	Y	8	
5	4015000026	垫圈GB93-12-65Mn	WASHER GB93-12-65Mn	N	8	
6	4110000843	中间传动轴CDZP-601	MIDDLE TRANSMISSION SHAFT CDZP-601	Y	1	
7	4011000843	螺栓GB5786-M12*1.25*45EpZn-10.9	BOLT GB5786-M12*1.25*45EpZn-10.9	N	8	
8	4011000566	螺栓GB5785-M20*1.5*70EpZn-8.8	BOLT GB5785-M20*1.5*70EpZn-8.8	N	2	
9	4013000160	螺母GB889.2-M20*1.5EpZn-8	NUT GB889.2-M20*1.5 EpZn-8	N	2	
10	4015000176	垫圈GB97.1-20EpZn-300HV	WASHER GB97.1-20EpZn-300HV	N	4	
11	4110000842	前传动轴CDZP-583	FRONT TRANSMISSION SHAFT CDZP-583	Y	1	
12	4090000011	低碳钢丝GB343-1.6*200-SZ	STEEL WIRE GB343-1.2*1200-SZ	Y	1	

后桥总成 REAR AXLE ASSEMBLY

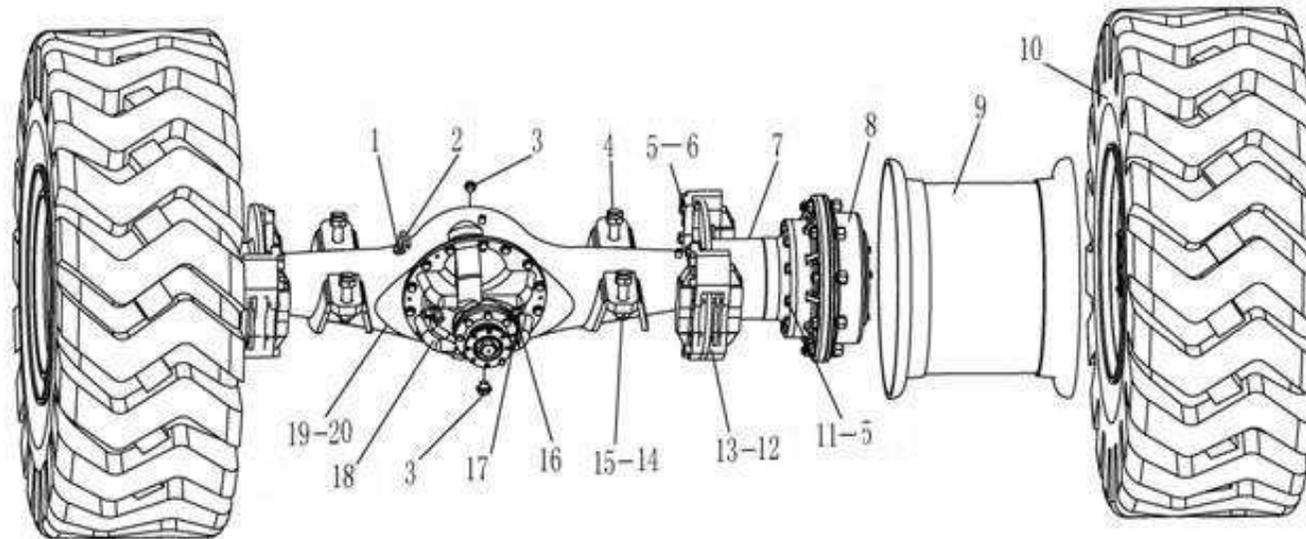

序号 Key	零件代号 Part No.	名称 Description	是否配件 Spare parts Y/N	数量 Qty	备注 Remarks
1	4013000078	螺母GB6173-M10*1EpZn-05	N	1	
2	29070000051	透气管	Y	1	
3	29070012481	磁性螺塞	Y	2	
4	29090001031	后桥螺栓	Y	8	
5	4015000030	垫圈GB93-20-65Mn	N	36	
6	29070000101	螺栓	Y	16	
7	3090900009	制动盘	Y	2	
8	29070009271	轮边减速器	Y	1	
9	4190000414	轮辋	Y	2	
10	4110000005	轮胎GB2980-20.5-25	Y	2	
11	4011000130	螺栓GB5786-M20*1.5*50EpZn-8.8	N	20	
12	4120001739	制动钳	Y	2	
13	4120001740	放气嘴	Y	8	
14	4015000032	垫圈GB93-30-65Mn	N	8	
15	4013000064	螺母GB889.2-M30*2EpZn-8	N	8	
16	4044000082	标牌LGB402-E/A504	Y	1	
17	4019000012	铆钉GB827-3*5-BL2	N	4	
18	29090001061	后主传动	Y	1	
19	29090007691	后桥壳总成	Y	1	
20	29090007681	A504后驱动桥总成	Y	1	



后传动总成 REAR AXLE MAIN DRIVE ASSEMBLY

序号 Key	零件代号 Part No.	名称 Description	是否配件 Spare parts Y/N	数量 Qty	备注 Remarks
1	4013000066	螺母GB889.2-M33*1.5-8	N	1	
2	29070001121	垫圈	Y	1	
3	29070001181	调整垫片	Y	3	
4	29070001191	调整垫片	Y	4	
5	29070001131	输入法兰	Y	1	
6	4011000067	螺栓GB5782-M14*55EpZn-8.8	N	7	
7	4015000027	垫圈GB93-14-65Mn	N	7	
8	29070001161	垫密片	Y	1	
9	4011000186	螺栓GB5782-M12*55EpZn-8.8	N	1	
10	4015000026	垫圈GB93-12-65Mn	N	1	
11	29070001141	密封盖	Y	1	
12	4030000049	油封HG4-692-SG80*100*12	Y	1	
13	4021000030	滚动轴承GB297-31313	Y	1	
14	29070001171	轴承套	Y	1	
15	29070000181	垫片	Y	2	
16	29070001151	轴套	Y	1	
17	29070000191	垫片	Y	2	
18	29070001201	调整垫片	Y	5	
19	29070000201	垫片	Y	3	
20	4021000032	滚动轴承GB297-31314	Y	1	
21	29070000211	垫片	Y	3	
22	29070000461	固定销	Y	4	



后传动总成 REAR AXLE MAIN DRIVE ASSEMBLY

序号 Key	零件代号 Part No.	名称 Description	是否配件 Spare parts Y/N	数量 Qty	备注 Remarks
23	4021000036	滚动轴承GB297-32216	BEARING GB297-32216	Y	2
24	29070000351	调整螺母	ADJUSTING NUT	Y	2
25	4016000124	销GB119.2-10u8*30	PIN GB119.2-10u8*30	N	2
26	29070001221	托架	CARRIER	N	1
27	29070000311	锁紧片	LOCKING LEAF	Y	1
28	4013000052	螺母GB6173-M27*2-05	NUT GB6173-M27*2-05	N	1
29	29070000301	止推螺栓	BOLT	Y	1
30	29070000391	轴承座	CAGE	N	2
31	29070000401	锁紧片	LOCKING LEAF	Y	2
32	4015000025	垫圈GB93-10-65Mn	WASHER GB93-10-65Mn	N	2
33	4011000597	螺栓GB5786-M10*1*20EpZn-8.8	BOLT GB5786-M10*1*20EpZn-8.8	N	2
34	29070001301	垫圈	WASHER	Y	4
35	4011000126	螺栓GB5786-M16*1.5*40EpZn-8.8	BOLT GB5786-M16*1.5*40EpZn-8.8	N	14
36	29070009521	螺栓	BOLT	Y	4
37	29090001091	主动螺旋伞齿轮（右）	SPIRAL BEVEL GEAR PINION(RIGHT)	N	1
38	4021000027	滚动轴承GB283-NUP2307	BEARING GB283-NUP2307	Y	1
39	4015000020	挡圈GB894.1-35-65Mn	RETAINER RING GB894.1-35-65Mn	N	1
40	29070000331	锥齿轮垫片	WASHER THRUST	Y	4
41	29070000341	锥齿轮	GEAR PINION	Y	4
42	29070009511	垫圈	WASHER	Y	20
43	4013000198	螺母GB6176-M16*1.5-10	NUT GB6176-M16*1.5-10	N	20
44	29070000431	差速器左壳	LEFT CASE DIFFERENTIAL MECHANISM	N	1



后传动总成 REAR AXLE MAIN DRIVE ASSEMBLY

序号 Key	零件代号 Part No.	名称 Description	是否配件 Spare parts Y/N	数量 Qty	备注 Remarks	
45	29070000381	半轴齿轮垫片	HALF AXLE GEAR SPACER	Y	2	
46	29070000371	半轴齿轮	HALF AXLE GEAR	Y	2	
47	29070000411	十字轴	CROSS AXLE	Y	1	
48	29090000081	从动螺旋伞齿轮（左）	LARGE SPRIAL BEVELGEAR (LEFT)	N	1	
49	29070000361	差速器右壳	RIGHT CASE DIFFERENTIAL MECHANISM	N	1	
50	29070009491	螺栓	BOLT	Y	8	
51	29070009501	螺栓	BOLT	Y	12	
52	4015000098	垫圈GB93-16-65Mn	WASHER GB93-16-65Mn	N	14	
53	29070001321	托架总成	BRACKET ASSEMBLY	Y	1	
54	3050900203	后主从动螺旋伞齿轮	REAR LARGE SPRIAL BEVELGEAR	Y	1	
55	2050900079	差速器左右壳	LEFT 、 RIGHT CASE DIFFERENTIAL MECHANISM	Y	1	
56	29070013031	调整垫片	ADJUSTING SHIM	Y	2	
57	29070013041	调整垫片	ADJUSTING SHIM	Y	2	

轮边减速器总成 FINAL DRIVE ASSEMBLY

序号 Key	零件代号 Part No.	名称 Description	是否配件 Spare parts Y/N	数量 Qty	备注 Remarks
1	29070000541	垫片	Y	6	
2	29070000551	挡环	Y	6	
3	29070000561	行星齿轮	Y	3	
4	4090000004	滚针GB309-5*45-GCr15	Y	93	
5	29070000081	轮辋螺母	Y	10	
6	29070000621	轮辋螺栓	Y	10	
7	29070009281	半轴	Y	1	
8	4013000203	螺母GB6171-M20*1.5EpZn-10	N	10	
9	4015000030	垫圈GB93-20-65Mn	N	10	
10	29070001241	轮毂	Y	1	
11	29070007611	行星轮架	Y	1	
12	4090000008	钢球GB308-9.525-GCr15	Y	3	
13	29070000611	行星齿轮轴	Y	3	
14	4120000080	螺塞Q/ZB286-ZG3/4"-Q235A	Y	1	
15	4090000006	钢球GB308-17.462-GCr15	Y	1	
16	29070009161	定位块	Y	1	
17	29070000511	太阳齿轮	Y	1	
18	4015000022	挡圈GB894.1-52-65Mn	N	1	
19	29070007621	盖	Y	1	
20	4015000025	垫圈GB93-10-65Mn	N	10	
21	4011000084	螺栓GB5783-M10*30EpZn-8.8	N	10	
22	4014000016	螺钉GB70-M10*1*20EpZn-8.8	N	1	

轮边减速器总成 FINAL DRIVE ASSEMBLY

序号 Key	零件代号 Part No.	名称 Description	是否配件 Spare parts Y/N	数量 Qty	备注 Remarks
23	29070000571	圆螺母	Y	1	
24	29070000481	驱动桥内齿轮	Y	1	
25	4041000020	O形圈LGB308-440*3.5	Y	1	
26	4021000037	滚动轴承GB297-32221	Y	1	
27	4021000033	滚动轴承GB297-32024	Y	1	
28	29070001261	隔套	Y	1	
29	4030000047	骨架油封HG4-692-PD150*180*16	Y	1	
30	29070001271	垫片	Y	1	
31	29070001231	油封端盖	Y	1	
32	4015000036	垫圈GB93-8-65Mn	N	6	
33	4011000298	螺栓GB5782-M8*45EpZn-8.8	N	6	



制动钳(371328) DISK BRAKE(371328)

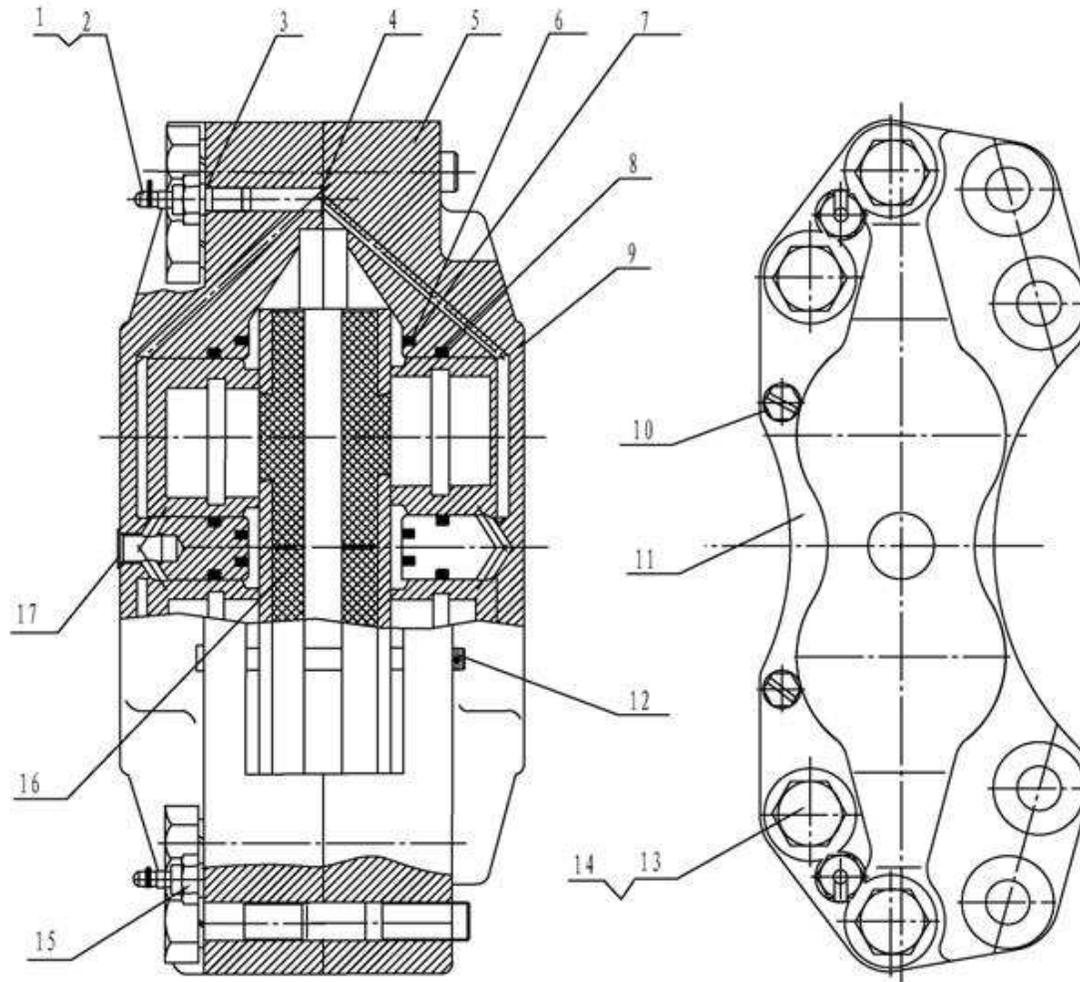

序号 Key	零件代号 Part No.	名称 Description	是否配件 Spare parts Y/N	数量 Qty	备注 Remarks	
1	4120001739001	橡皮帽JS-ZL50-001	RUBBER COVER JS-ZL50-001	Y	2	
2	4120001740	放气嘴	VENT NOZZLE	Y	1	
3	4120001739003	O形圈16*2.4 JS-ZL50-014	O-RING 16*2.4 JS-ZL50-014	Y	2	
4	4120001739004	O形圈20*2.4 JS-ZL50-015	O-RING 20*2.4 JS-ZL50-015	Y	2	
5	4120001739005	外钳JS-ZL50-003	EXTERNAL PLIERS JS-ZL50-003	N	1	
6	4120001739006	防尘罩JS-ZL50-004	DUST CAP JS-ZL50-004	Y	4	
7	4120001739007	卡圈JS-ZL50-005	RETAINER RING JS-ZL50-005	Y	4	
8	4120001739008	矩形密封圈JS-ZL50-006	SQUQRE SEAL JS-ZL50-006	Y	4	
9	4120001739009	活塞JS-ZL50-007	PISTON JS-ZL50-007	N	4	
10	4120001739010	螺栓销JS-ZL50-008	BOLT PIN JS-ZL50-008	N	2	
11	4120001739011	内钳JS-ZL50-009	INTERNAL PLIERS JS-ZL50-009	N	1	
12	4016000101	开口销GB91-2.5*20EpZn-Q235A	SPLIT PIN	N	1	
13	4120001739013	螺栓M22 (10.9) JS-ZL50-010	BOLT M22 (10.9) JS-ZL50-010	N	4	
14	4015000087	垫圈GB93-22-65Mn	WASHER GB93-22-65Mn	N	1	
15	4120001739015	接头JS-ZL50-011	CONNECTOR JS-ZL50-011	Y	2	
16	4120001739016	制动片JS-ZL50-012	BRAKE SHOE JS-ZL50-012	Y	2	
17	4120001739017	防尘塞JS-ZL50-013	DUST CORK JS-ZL50-013	Y	1	

制动钳(371104) DISC BRAKE(371104)

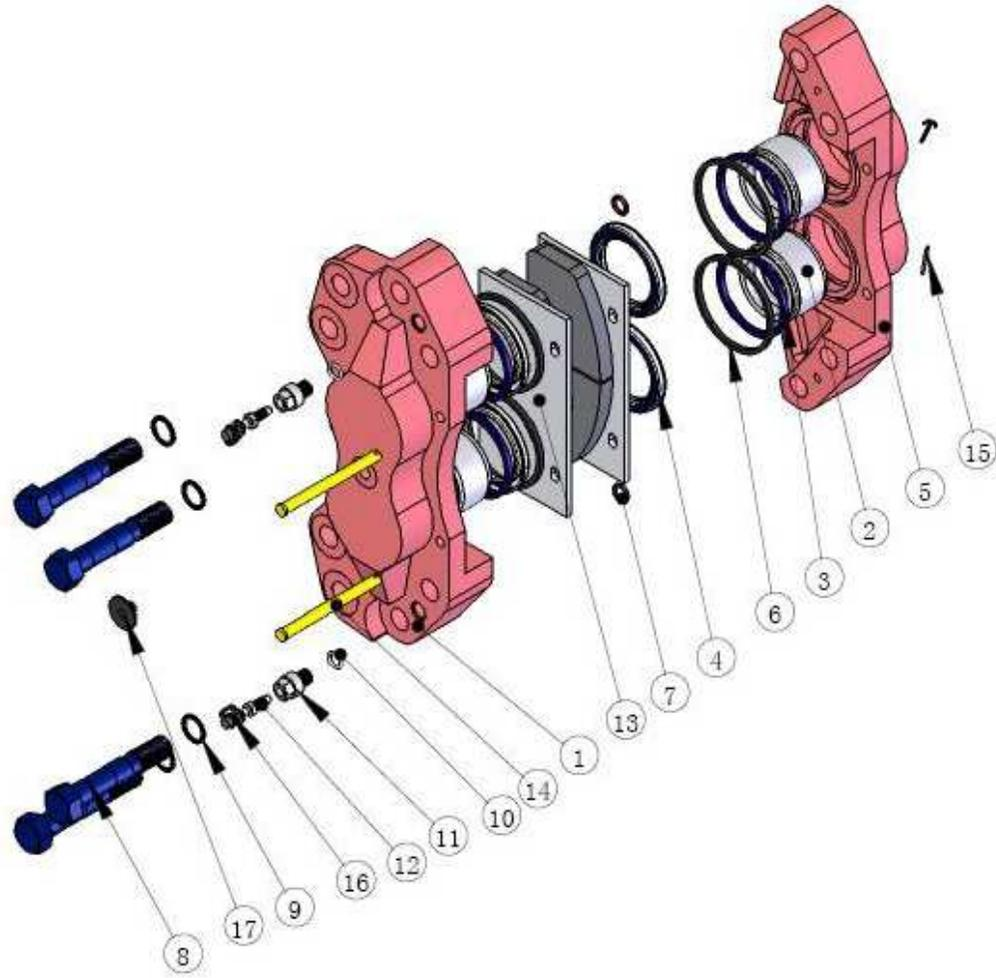

序号 Key	零件代号 Part No.	名称 Description	是否配件 Spare parts Y/N	数量 Qty	备注 Remarks
1	4120001739050	内钳体JF.A.ZL4050.01	INTERNAL PLIERS JF.A.ZL4050.01	N	1
2	4120001739051	活塞JF.A.ZL4050.09	PISTON JF.A.ZL4050.09	N	4
3	4120001739052	矩形密封圈JF.A.ZL4050.07	SQUQRE SEAL JF.A.ZL4050.07	Y	4
4	4120001739053	防尘罩JF.A.ZL4050.08	DUST CAP JF.A.ZL4050.08	Y	4
5	4120001739054	外钳体JF.A.ZL4050.01	EXTERNAL PLIERS JF.A.ZL4050.01	N	1
6	4120001739055	卡圈JF.A.ZL4050.11	RETAINER RING JF.A.ZL4050.11	Y	4
7	4120001739056	O型密封圈ZBJ22002-88	O-RING ZBJ22002-88	Y	2
8	4120001739057	螺栓M22 JF.A.ZL4050.13	BOLT M22 JF.A.ZL4050.13	Y	4
9	4015000087	垫圈GB93-22-65Mn	WASHER GB93-22-65Mn	N	4
10	4120001739056	O型密封圈ZBJ22002-88	O-RING ZBJ22002-88	Y	2
11	4120001739058	放气嘴座JF.A.ZL4050.05	VENT NOZZLE SEAT JF.A.ZL4050.05	Y	2
12	4120001739059	放气嘴JF.A.ZL4050.04	VENT NOZZLE JF.A.ZL4050.04	Y	2
13	4120001739060	制动片JF.A.ZL4050.A.06	BRAKE SHOE JF.A.ZL4050.A.06	Y	2
14	4120001739061	销子JF.A.ZL4050.A.12	PIN JF.A.ZL4050.A.12	Y	2
15	4016000264	开口销GB91-2.5*32EpZn-Q235A	PIN GB91-2.5*32EpZn-Q235A	Y	2
16	4120001739062	橡皮帽JF.A.ZL4050.03	RUBBER COVER JF.A.ZL4050.03	Y	2
17	4120001739063	皮塞JF.A.ZL4050.10	PLUG JF.A.ZL4050.10	Y	1



**F 工作装置液压系统**  
**IMPLEMENT HYDRAULIC SYSTEM**

山东临工工程机械有限公司  
**SHANDONG LINGONG CONSTRUCTION MACHINERY CO.,LTD.**

液压操纵总成 HYDRAULIC CONTROL SYSTEM

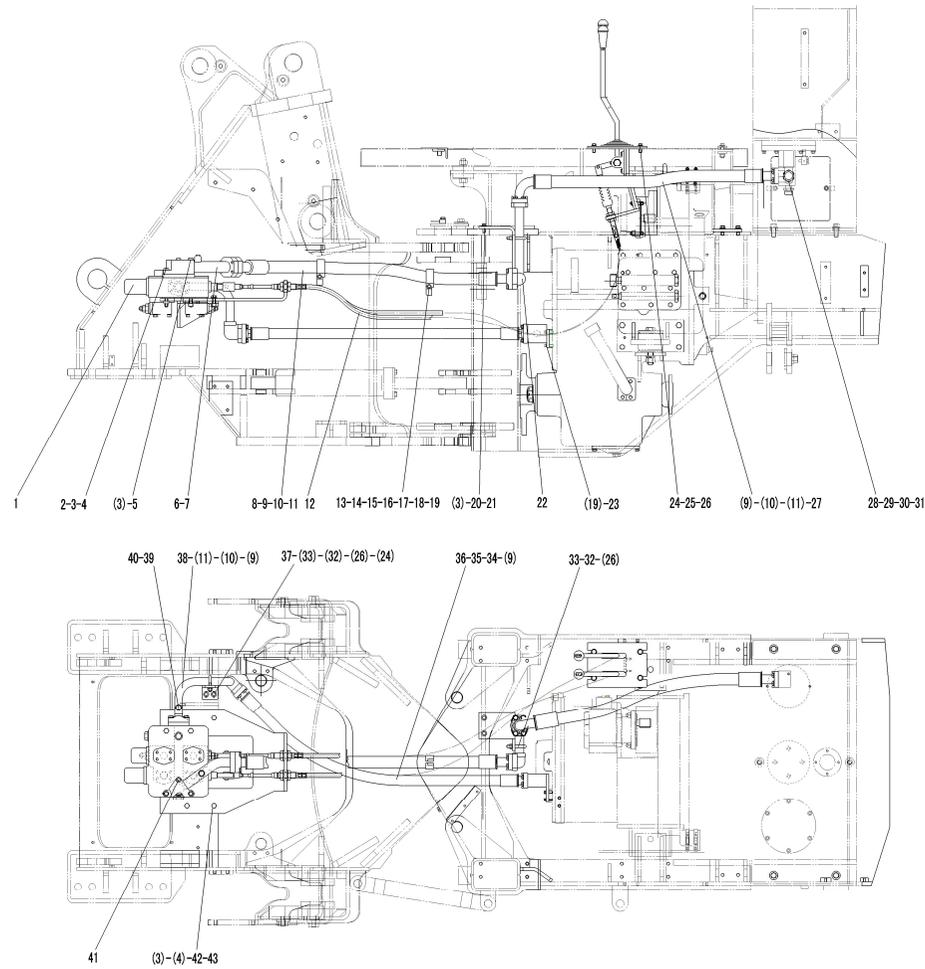

序号 Key	零件代号 Part No.	名称 Description	是否配件 Spare parts Y/N	数量 Qty	备注 Remarks
1	4120002038	多路阀DFS-32-16	CONTROL VALVE DFS-32-16	Y	1
2	4011000056	螺栓GB5782-M12*145EpZn-8.8	BOLT GB5782-M12*145EpZn-8.8	N	3
3	4015000168	垫圈GB97.1-12EpZn-300HV	WASHER GB97.1-12EpZn-300HV	N	10
4	4013000011	螺母GB6170-M12EpZn-8	NUT GB6170-M12 EpZn-8	N	8
5	4011000058	螺栓GB5782-M12*175EpZn-8.8	BOLT GB5782-M12*175EpZn-8.8	N	1
6	29120005021	多路阀回油钢管	TUBE	Y	1
7	4030000130	O形圈GB3452.1-47.5*3.55G	O-RING GB3452.1-47.5*3.55G	Y	1
8	4041000705	软管LGB163-012112	PIPE LGB163012112	Y	1
9	4011000475	螺栓GB16674-M10*30EpZn-8.8	BOLT GB16674-M10*30EpZn-8.8	N	28
10	4041000056	分体法兰LGB117-312550	FLANGE LGB117-312550	Y	5
11	4030000029	O形圈GB3452.1-37.5*3.55G	O-RING GB3452.1-37.5*3.55G	Y	5
12	29120016802	软轴	AXIS	Y	2
13	29120015431	管夹	CLAMP	Y	2
14	4041000869	缓冲套LGB123-0740	CUSHION LGB123-0740	Y	2
15	4041001188	缓冲套LGB123-0219	CUSHION LGB123-0219	Y	2
16	4015000072	垫圈GB97.1-8EpZn-300HV	WASHER GB97.1-8EpZn-300HV	N	2
17	4013000033	螺母GB6170-M8EpZn-8	NUT GB6170-M8EpZn-8	N	2
18	29120015711	管夹	CLAMP	Y	2
19	4011000458	螺栓GB16674-M8*20EpZn-8.8	BOLT GB16674-M8*20Ep.Zn-8.8	N	6
20	4011000087	螺栓GB5783-M12*20EpZn-8.8	BOLT GB5783-M12*20EpZn-8.8	N	2
21	29120013521	固定板	MOUNTED PLATE	Y	1
22	29120016771	钢管	TUBE	Y	1

液压操纵总成 HYDRAULIC CONTROL SYSTEM

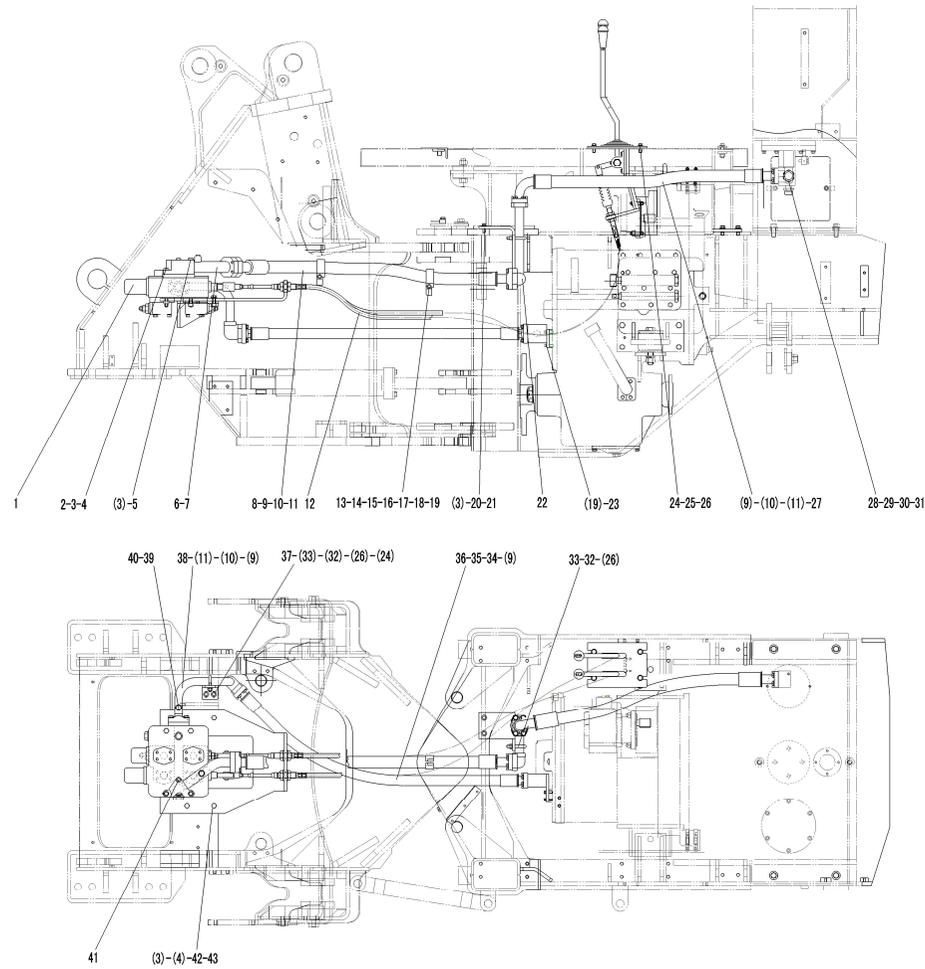

序号 Key	零件代号 Part No.	名称 Description	是否配件 Spare parts Y/N	数量 Qty	备注 Remarks	
23	29120004041	二通块	TWO-WAY MASS	Y	1	
24	4011000474	螺栓GB16674-M10*25EpZn-8.8	BOLT GB16674-M10*25EpZn-8.8	N	6	
25	4120002148	操纵机构LG12-936CZJG02	OPERATING GEAR LG12-936CZJG02	Y	1	
26	4015000162	垫圈GB97.1-10EpZn-300HV	WASHER GB97.1-10EpZn-300HV	N	12	
27	4041000532	软管LGB162-012105	TUBE LGB162012105	Y	1	
28	4041000728	堵塞LGB142-01805	PLUG LGB142-01805	Y	1	
29	4030000490	O形圈GB3452.1-10.0*1.80G	O-RING GB3452.1-10.0*1.80G	Y	1	
30	4041000598	堵塞LGB142-01604	PLUG LGB142-01604	Y	1	
31	4030000240	O形圈GB3452.1-8.00*1.80G	O-RING GB3452.1-8.00*1.80G	Y	1	
32	4041001141	U形螺栓LGB159-03646	U-BOLT LGB159-03646	Y	3	
33	4013000007	螺母GB6170-M10EpZn-8	NUT GB6170-M10EpZn-8	N	6	
34	4041000698	软管LGB107-010125	PIPE LGB107010125	Y	1	
35	4041000043	分体法兰LGB117-310490	FLANGE LGB117310490	Y	2	
36	4030000026	O形圈GB3452.1-32.5*3.55G	O-RING GB3452.1-32.5*3.55G	Y	2	
37	29120005101	固定支架	FRAME	Y	1	
38	29120004051	多路阀进油钢管	TUBE	Y	1	
39	4041000774	螺塞LGB135-01422	PLUG LGB13501421	Y	2	
40	4041000767	O形圈LGB168-11124	O-RING LGB168-11124	Y	2	
41	4011000230	螺栓GB16674-M10*65EpZn-8.8	BOLT GB16674-M10*65EpZn-8.8	N	1	
42	29120017761	多路阀固定板	claping plate of mutiple congtrrol valve	Y	1	
43	4011000090	螺栓GB5783-M12*35EpZn-8.8	BOLT GB5783-M12*35EpZn-8.8	N	4	

工作泵总成 WORKING PUMP ASSEMBLY

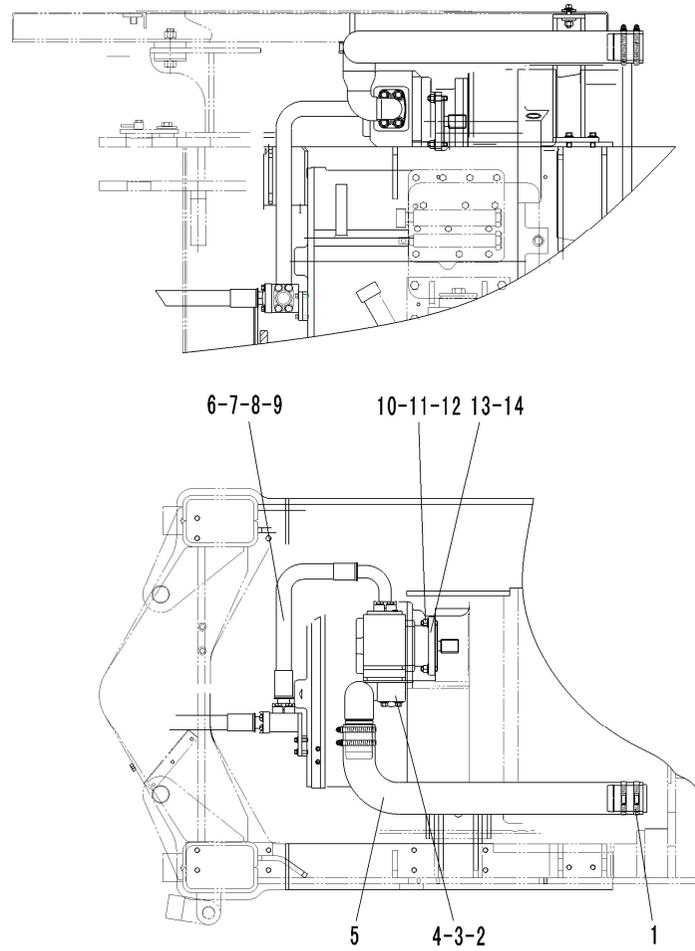

序号 Key	零件代号 Part No.	名称 Description	是否配件 Spare parts Y/N	数量 Qty	备注 Remarks	
1	4017000013	喉箍JB8870-d90	CLAMP JB8870-d90	N	4	
2	29110004021	工作泵吸油钢管	INTAKE OIL TUBE OF PUMP	Y	1	
3	4011000337	螺栓GB16674-M12*60EpZn-8.8	BOLT GB16674-M12*60EpZn-8.8	N	4	
4	4030000235	O形圈GB3452.1-43.7*3.55G	O-RING GB3452.1-43.7*3.55G	Y	1	
5	29110008991	吸油胶管	INTAKE OIL HOSE	Y	1	
6	29110004041	工作泵出油胶管	OUT OIL TUBE OF PUMP	Y	1	
7	4011000475	螺栓GB16674-M10*30EpZn-8.8	BOLT GB16674-M10*30EpZn-8.8	N	8	
8	4041000056	分体法兰LGB117-312550	FLANGE LGB117-312550	Y	2	
9	4030000029	O形圈GB3452.1-37.5*3.55G	O-RING GB3452.1-37.5*3.55G	Y	2	
10	4013000011	螺母GB6170-M12EpZn-8	NUT GB6170-M12 EpZn-8	N	4	
11	4015000168	垫圈GB97.1-12EpZn-300HV	WASHER GB97.1-12EpZn-300HV	N	4	
12	4012000003	螺柱GB898-M12*35EpZn-8.8	DOUBLE-SCREW BOLT GB898-M12*35EpZn-8.8	N	4	
13	4120002520	齿轮泵JHP3125	GEAR PUMP JHP3125	Y	1	
14	29110000041	泵用密封垫	SEALING WASHER	Y	1	

举升缸总成 LIFTING CYLINDER ASSEMBLY

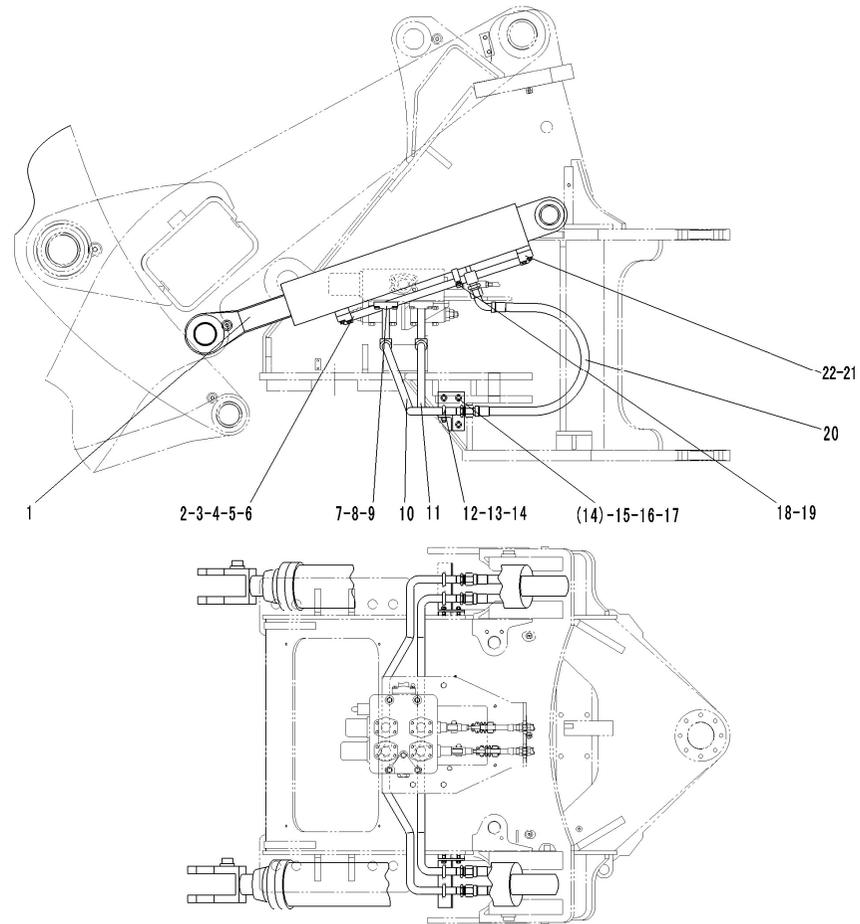

序号 Key	零件代号 Part No.	名称 Description	是否配件 Spare parts Y/N	数量 Qty	备注 Remarks	
1	4120002522	动臂油缸HSGF-140*80*779-1234	BOOM CYLINDER HSGF-140*80*779-1234	Y	2	
2	4030000279	O形圈GB3452.1-25.0*3.55G	O-RING GB3452.1-25*3.55G	Y	4	
3	4011000309	螺栓GB16674-M10*50EpZn-8.8	BOLT GB16674-M10*50EpZn-8.8	N	8	
4	4011000164	螺栓GB16674-M10*35EpZn-8.8	BOLT GB16674-M10*35EpZn-8.8	N	8	
5	29130012761	左动臂缸小腔钢管	STEEL PIPE	Y	1	
6	29130012741	右动臂缸小腔钢管	STEEL PIPE	N	1	
7	4030000029	O形圈GB3452.1-37.5*3.55G	O-RING GB3452.1-37.5*3.55G	Y	2	
8	4041000056	分体法兰LGB117-312550	FLANGE LGB117-312550	Y	2	
9	4011000475	螺栓GB16674-M10*30EpZn-8.8	BOLT GB16674-M10*30EpZn-8.8	N	8	
10	29130012661	动臂联小腔三通钢管	STEEL TUBE	Y	1	
11	29130012731	动臂联大腔三通钢管	STEEL TUBE	Y	1	
12	4041001415	U形螺栓LGB159-02535	BOLT(U SHAPE)LGB159-02535	Y	4	
13	4013000007	螺母GB6170-M10EpZn-8	NUT GB6170-M10EpZn-8	N	8	
14	4015000162	垫圈GB97.1-10EpZn-300HV	WASHER GB97.1-10EpZn-300HV	N	14	
15	29130004091	固定支架A	STEADY REST A	Y	1	
16	29130004111	固定支架B	STEADY REST B	Y	1	
17	4011000080	螺栓GB5783-M10*16EpZn-8.8	BOLT GB5783-M10*16EpZn-8.8	N	6	
18	4011000458	螺栓GB16674-M8*20EpZn-8.8	BOLT GB16674-M8*20Ep.Zn-8.8	N	4	
19	29130004081	管夹	CLAMP	Y	2	
20	29130004101	动臂缸胶管	HOSE	Y	4	
21	29130012861	右动臂缸大腔钢管	STEEL PIPE	Y	1	
22	29130012871	左动臂缸大腔钢管	STEEL PIPE	Y	1	

转斗缸总成 DUMP CYLINDER ASSEMBLY

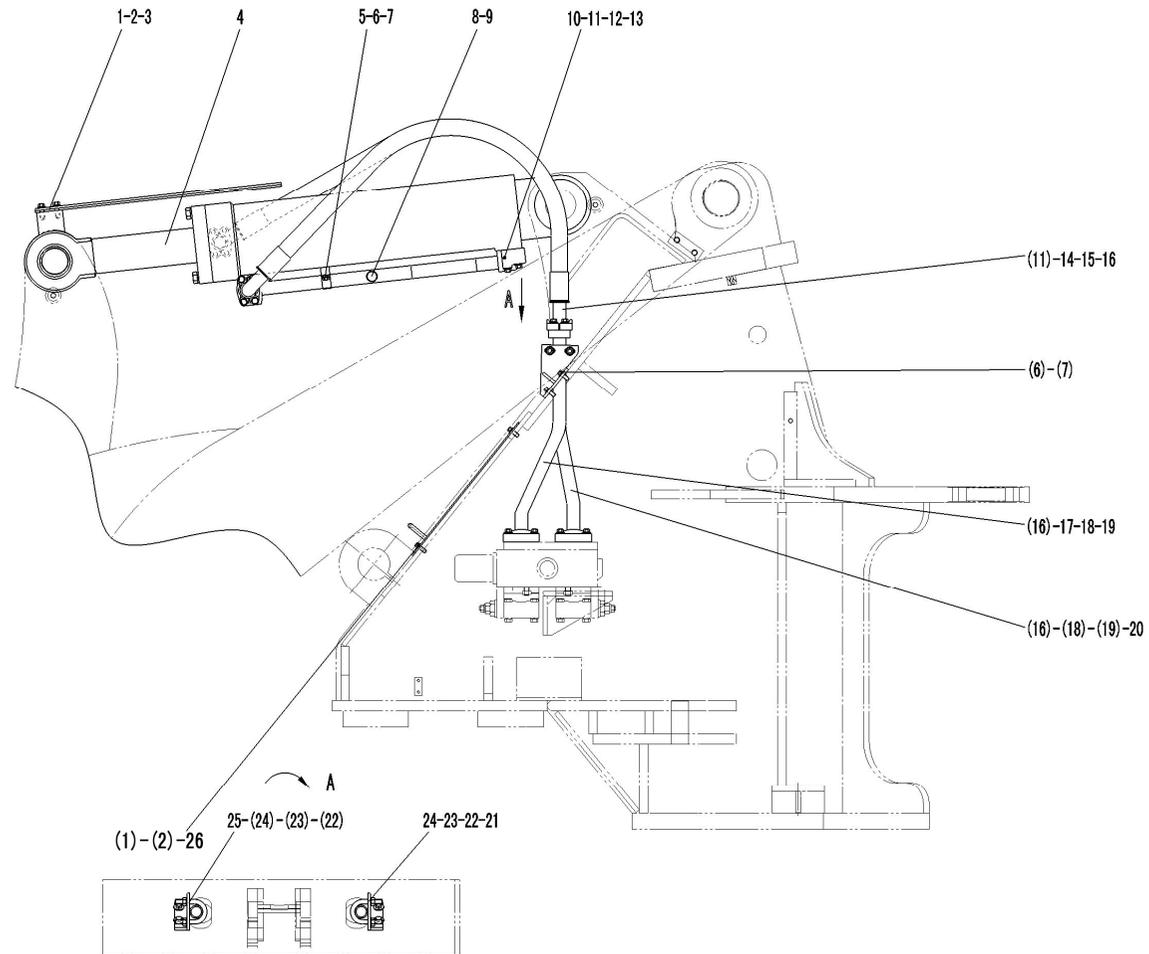

序号 Key	零件代号 Part No.	名称 Description	是否配件 Spare parts Y/N	数量 Qty	备注 Remarks	
1	4011000081	螺栓GB5783-M10*20EpZn-8.8	BOLT GB5783-M10*20EpZn-8.8	N	8	
2	4015000197	垫圈GB96.1-10EpZn-300HV	WASHER GB96.1-10EpZn-300HV	N	8	
3	29140009881	放平护板	INDICATING ROD OF BUCKET	Y	1	
4	4120002763	转斗油缸HSGF-165*80*496-954	TILT CYLINDER HSGF-165*80*496-954	Y	1	
5	29130000111	管夹	CLAMP	Y	1	
6	4011000105	螺栓GB5783-M8*20EpZn-8.8	BOLT GB5783-M8*20EpZn-8.8	N	6	
7	4015000072	垫圈GB97.1-8EpZn-300HV	WASHER GB97.1-8EpZn-300HV	N	10	
8	4041000774	螺塞LGB135-01422	PLUG LGB13501421	Y	1	
9	4041000767	O形圈LGB168-11124	O-RING LGB168-11124	Y	1	
10	29140012011	转斗缸大腔钢管	STEEL TUBE	Y	1	
11	4030000026	O形圈GB3452.1-32.5*3.55G	O-RING GB3452.1-32.5*3.55G	Y	5	
12	4011000309	螺栓GB16674-M10*50EpZn-8.8	BOLT GB16674-M10*50EpZn-8.8	N	2	
13	4011000473	螺栓GB16674-M10*55EpZn-8.8	BOLT GB16674-M10*55EpZn-8.8	N	2	
14	4041000703	软管LGB106-010120	TUBE LGB106-010120	Y	1	
15	4041000043	分体法兰LGB117-310490	FLANGE LGB117310490	Y	4	
16	4011000475	螺栓GB16674-M10*30EpZn-8.8	BOLT GB16674-M10*30EpZn-8.8	N	24	
17	29140011312	转斗联大腔钢管	STEEL PIPE	Y	1	
18	4030000029	O形圈GB3452.1-37.5*3.55G	O-RING GB3452.1-37.5*3.55G	Y	2	
19	4041000056	分体法兰LGB117-312550	FLANGE LGB117-312550	Y	2	
20	29140011302	转斗联小腔钢管	STEEL PIPE	Y	1	
21	29140004061	固定支架A	STEADY REST A	Y	1	
22	4041000958	U形螺栓LGB159-03040	U-BOLT LGB159-03040	Y	2	

转斗缸总成 DUMP CYLINDER ASSEMBLY

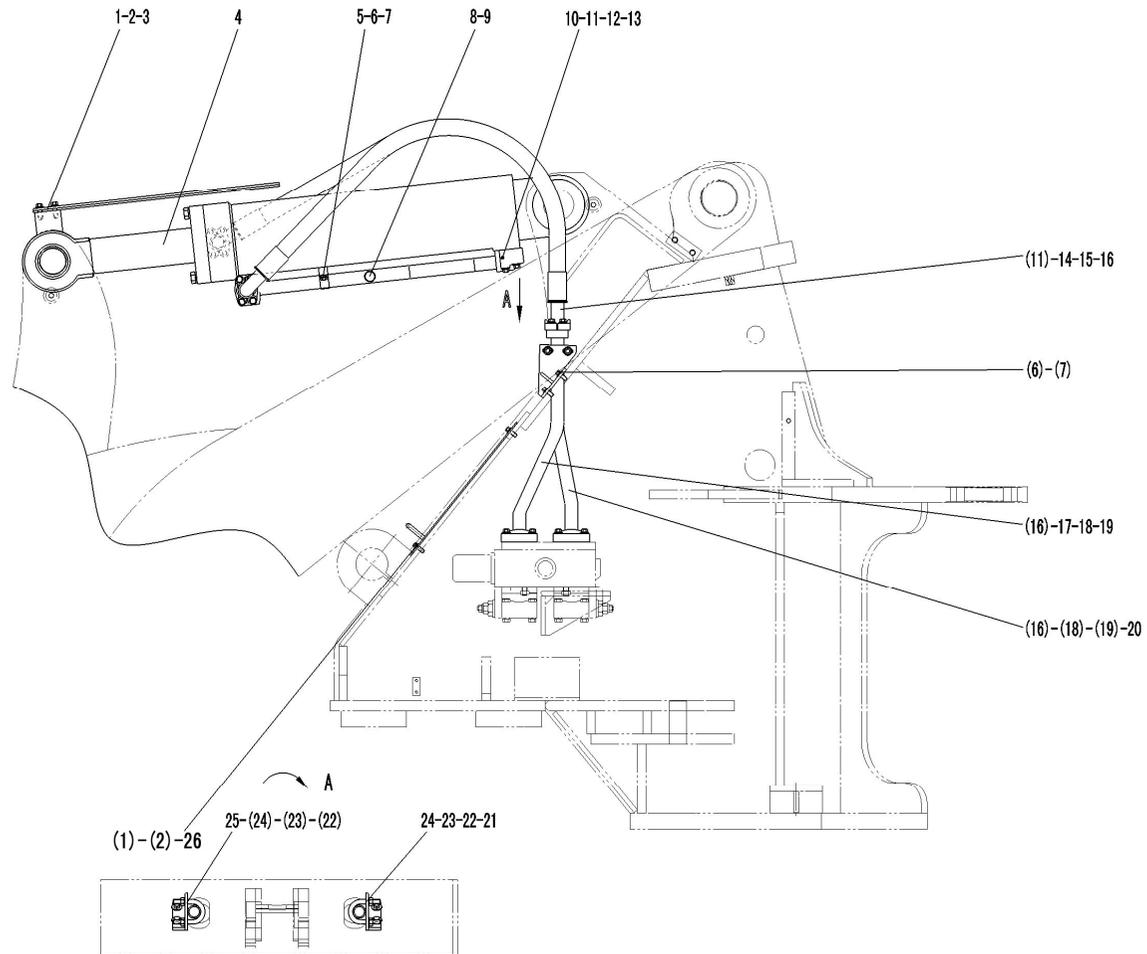

序号 Key	零件代号 Part No.	名称 Description	是否配件 Spare parts Y/N	数量 Qty	备注 Remarks
23	4013000007	螺母GB6170-M10EpZn-8	N	4	
24	4015000162	垫圈GB97.1-10EpZn-300HV	N	4	
25	29140004071	固定支架B	Y	1	
26	29140011342	前盖板	Y	1	



### 液压油箱总成 HYDRAULIC TANK ASSEMBLY

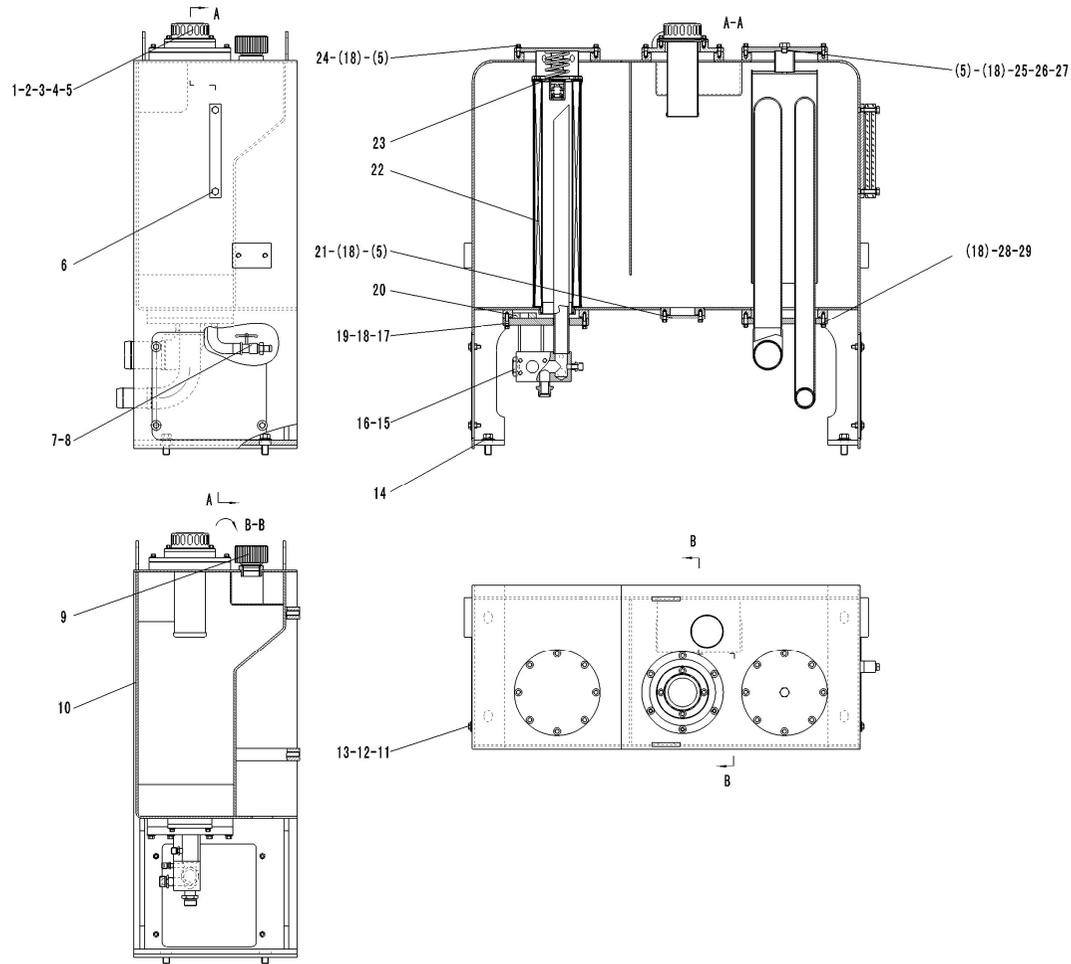

序号 Key	零件代号 Part No.	名称 Description	是否配件 Spare parts Y/N	数量 Qty	备注 Remarks
1	4120000452	加油滤芯SFM-323M	OIL-SUPPLYING FILTER SFM-323M	Y	1
2	4011000461	螺栓GB16674-M8*16EpZn-8.8	BOLT GB16674-M8*16EpZn-8.8	N	4
3	29100008361	法兰座	FLANGE SEAT	N	1
4	4030000452	O形圈GB3452.1-160*3.55G	O-RING GB3452.1-160*3.55G	Y	1
5	4011000458	螺栓GB16674-M8*20EpZn-8.8	BOLT GB16674-M8*20Ep.Zn-8.8	N	26
6	4120000093	液位计YWZ-200	GAUGE LEVEL YWZ-200	Y	1
7	4120000099	球阀MBS216-1/2"	BALL VALVE	Y	1
8	29100009061	放油接头	FITTING	Y	1
9	4120001088	换气过滤器L1.0807-31	GAS-EXCHANGE FILTER L1.00807-51	Y	1
10	29100013141	液压油箱体	HYDRAULIC TANK BODY	Y	1
11	29100008551	侧板	SIDE BROAD	Y	2
12	4011000106	螺栓GB5783-M8*25EpZn-8.8	BOLT GB5783-M8*25EpZn-8.8	N	8
13	4015000256	垫圈GB96.1-8EpZn-300HV	WASHER GB96.1-8EpZn-300HV	N	8
14	4011000449	螺栓GB16674-M16*35EpZn-8.8	BOLT GB16674-M16*35EpZn-8.8	N	4
15	4041000192	螺塞LGB135-03341	PLUG LGB13503341	Y	1
16	4041000765	O形圈LGB168-12931	O-RING LGB168-12931	Y	1
17	29100013231	回油法兰总成	RETURN OIL FLANGE ASSMEBLY	Y	1
18	4030000232	O形圈GB3452.1-170*3.55G	O-RING GB3452.1-170*3.55G	Y	5
19	4011000481	螺栓GB16674-M8*30EpZn-8.8	BOLT GB16674-M8*30Ep.Zn-8.8	N	8
20	4190000006	环形磁铁LG03-CT58*20*13	MAGNET		1
21	29100000361	法兰盖	FLANGE CAP	Y	1
22	29100000061	回油滤芯	STRAIN CORE	Y	1

### 液压油箱总成 HYDRAULIC TANK ASSEMBLY

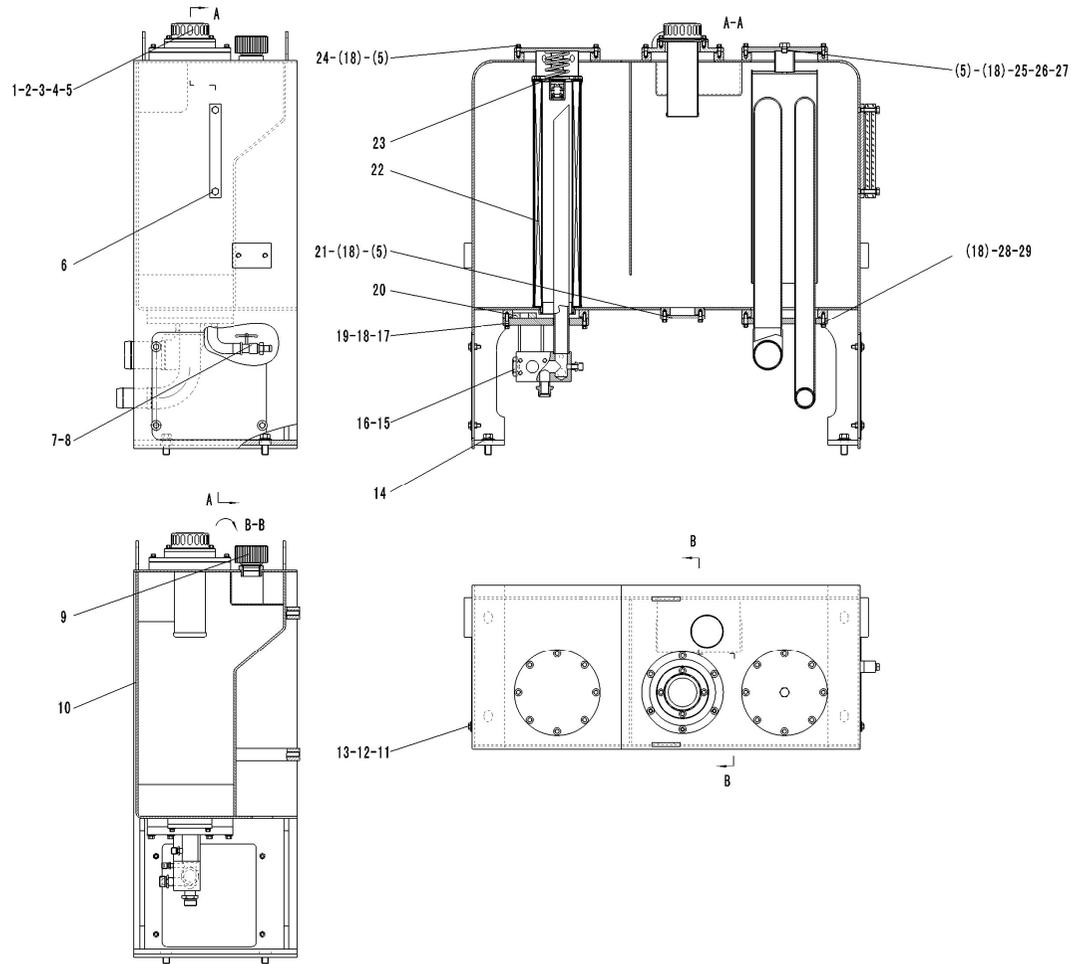

序号 Key	零件代号 Part No.	名称 Description	是否配件 Spare parts Y/N	数量 Qty	备注 Remarks
23	29100000051	弹簧	Y	1	
24	29100000041	回油法兰盖	Y	1	
25	4041000774	螺塞LGB135-01422	Y	1	
26	4041000767	O形圈LGB168-11124	Y	1	
27	29100013251	上部吸油法兰	Y	1	
28	29100013291	吸油法兰总成	Y	1	
29	4011000455	螺栓GB16674-M8*25EpZn-8.8	N	8	



转斗油缸 (371401) TILT CYLINDER

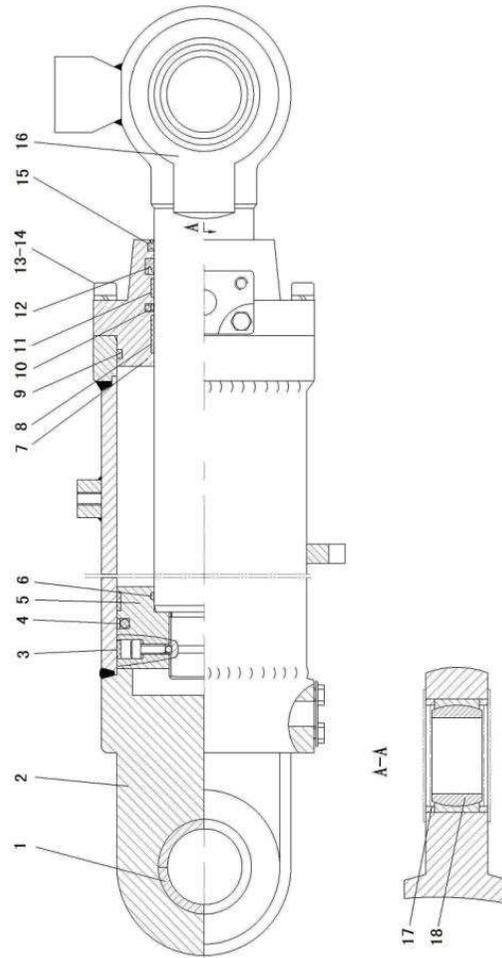

序号 Key	零件代号 Part No.	名称 Description	是否配件 Spare parts Y/N	数量 Qty	备注 Remarks	
1	4120002763003	衬套	BUSHING	Y	1	
2	4120002763004	缸体	CYLINDER BODY	N	1	
3	4120002763001	密封件包	SEALING KIT	Y	2	
4	4120002763001	密封件包	SEALING KIT	Y	1	
5	4120002763005	活塞	PISTON	N	1	
6	4120002763001	密封件包	SEALING KIT	Y	1	
7	4120002763006	缸盖	CYLINDER HEAD	N	1	
8	4120002763001	密封件包	SEALING KIT	Y	1	
9	4120002763001	密封件包	SEALING KIT	Y	1	
10	4120002763001	密封件包	SEALING KIT	Y	1	
11	4120002763001	密封件包	SEALING KIT	Y	1	
12	4120002763001	密封件包	SEALING KIT	Y	1	
13	4011000791	螺栓GB5785-M18*1.5*70EpZn-10.9	BOLT	N	10	
14	4015000029	垫圈GB93-18-65Mn	WASHER GB93-18-65Mn	N	10	
15	4120002763001	密封件包	SEALING KIT	Y	1	
16	4120002763002	活塞杆	PISTON ROD	Y	1	
17	4120002763007	挡块	STOPPER	N	2	
18	4021000043	关节轴承GB9163-GE70ES-2RS	SPHERICAL PLAIN BEARING	Y	1	

动臂油缸 (371401) LIFT ARM CYLINDER (371401)

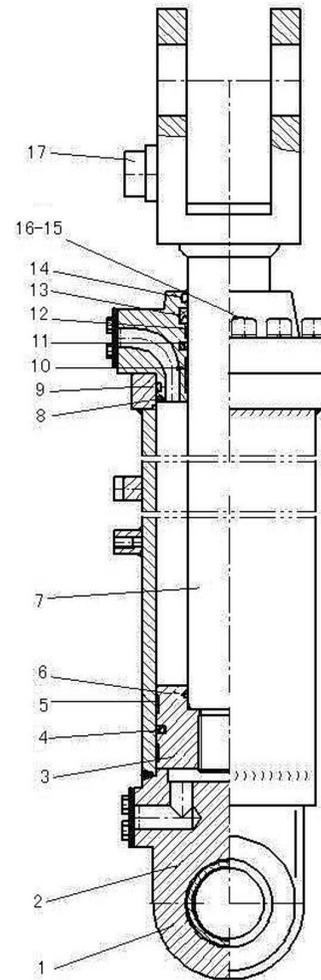

序号 Key	零件代号 Part No.	名称 Description	是否配件 Spare parts Y/N	数量 Qty	备注 Remarks	
1	4120002522002	衬套	BUSH	Y	1	
2	4120002522003	缸体	CYLINDER BODY	N	1	
3	4120002522004	活塞	PISTON	N	1	
4	4120002522001	密封件包	SEALING KIT	Y	1	
5	4120002522001	密封件包	SEALING KIT	Y	2	
6	4120002522001	密封件包	SEALING KIT	Y	1	
7	4120002522005	活塞杆	PISTON ROD	Y	1	
8	4120002522006	缸盖	CYLINDER HEAD	N	1	
9	4120002522001	密封件包	SEALING KIT	Y	1	
10	4120002522001	密封件包	SEALING KIT	Y	1	
11	4120002522001	密封件包	SEALING KIT	Y	1	
12	4120002522001	密封件包	SEALING KIT	Y	1	
13	4120002522001	密封件包	SEALING KIT	Y	1	
14	4120002522001	密封件包	SEALING KIT	Y	1	
15	4014000147	螺钉GB70.1-M12*45EpZn-10.9	SCREW GB70.1-M12*45EpZn-10.9	N	14	
16	4015000026	垫圈GB93-12-65Mn	WASHER GB93-12-65Mn	N	14	
17	4120002522007	座	SEAT	N	1	

多路阀DFS-32-16 (331001) MULTIPLE UNIT VALVE DFS-32-16

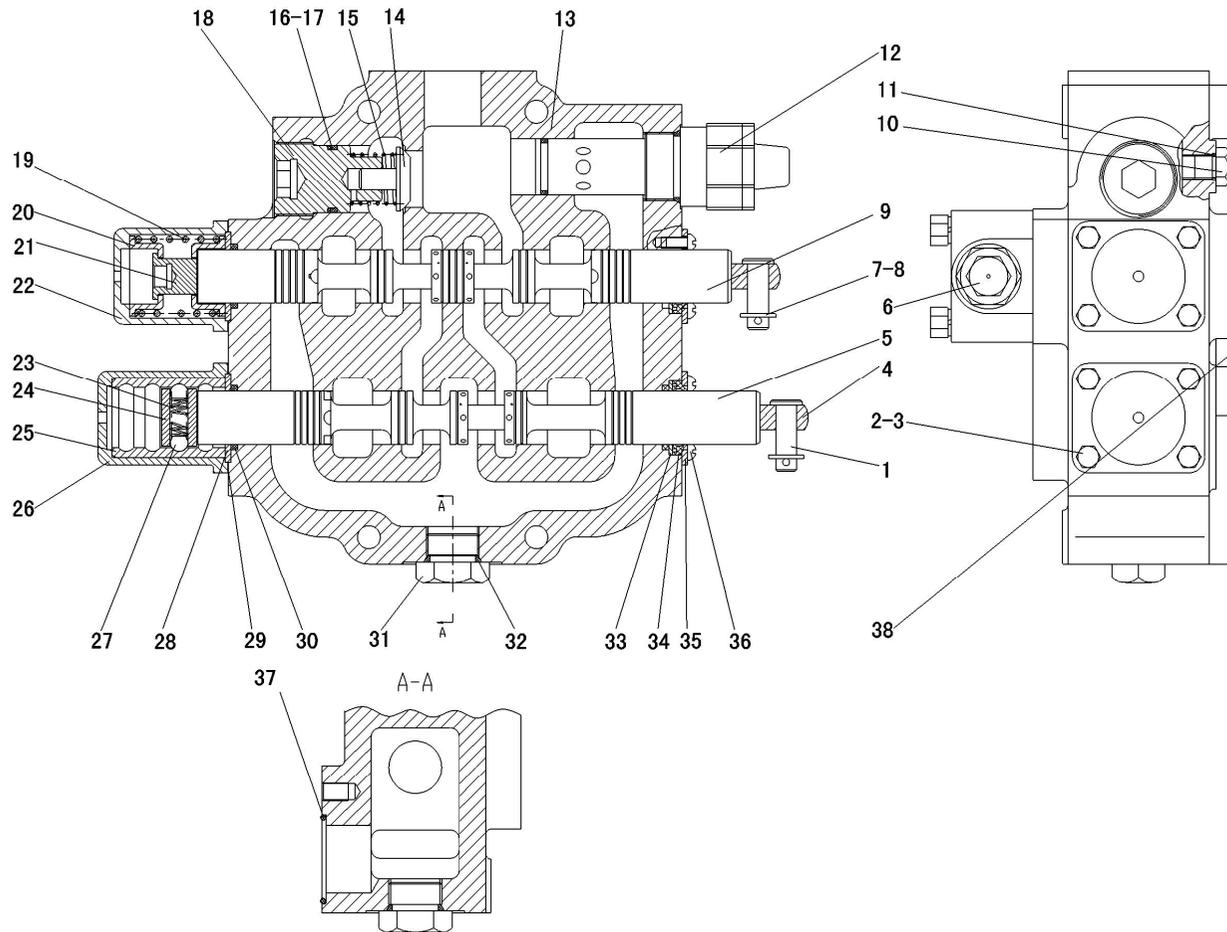

序号 Key	零件代号 Part No.	名称 Description	是否配件 Spare parts Y/N	数量 Qty	备注 Remarks
1	4120000703017	圆肩销DF-32-01	N	2	
2	4120002038003	螺栓GB5784-M8*20	N	8	
3	4015000036	垫圈GB93-8-65Mn	N	8	
4	4120002038004	连接头SD32-20	N	2	
5	4120002038005	动臂阀杆DFS-32III-01	Y	1	
6	4120002038002	过载补油阀ZL50106C	Y	2	
7	4016000035	开口销GB91-4*20EpZn-Q235A	N	2	
8	4015000168	垫圈GB97.1-12EpZn-300HV	N	2	
9	4120002038006	转斗阀杆DFS-32III-02	Y	1	
10	4120000703025	螺塞DF-32-19	N	1	
11	7200000438	O型圈	Y	3	
12	4120002038001	安全阀DFX-32-09	Y	1	
13	4120002038007	阀体DFS-32-04	N	1	
14	4120002038008	单向阀D32-17	Y	1	
15	4120001054023	弹簧D32-16	N	1	
16	4120002038009	O形密封圈GB1235-38*3.1	Y	1	
17	4120002038010	挡圈A GB1235-38*33	Y	1	
18	4120002038011	阀盖DFS-32-03	N	1	
19	4120002038012	弹簧DFS-32-05	Y	1	
20	4120002038013	弹簧座DFS-32-06	N	2	
21	4120002038014	杆头螺栓DFS-32-07	N	1	
22	4120002038015	端盖DFS-32-08	N	1	

多路阀DFS-32-16 (331001) MULTIPLE UNIT VALVE DFS-32-16

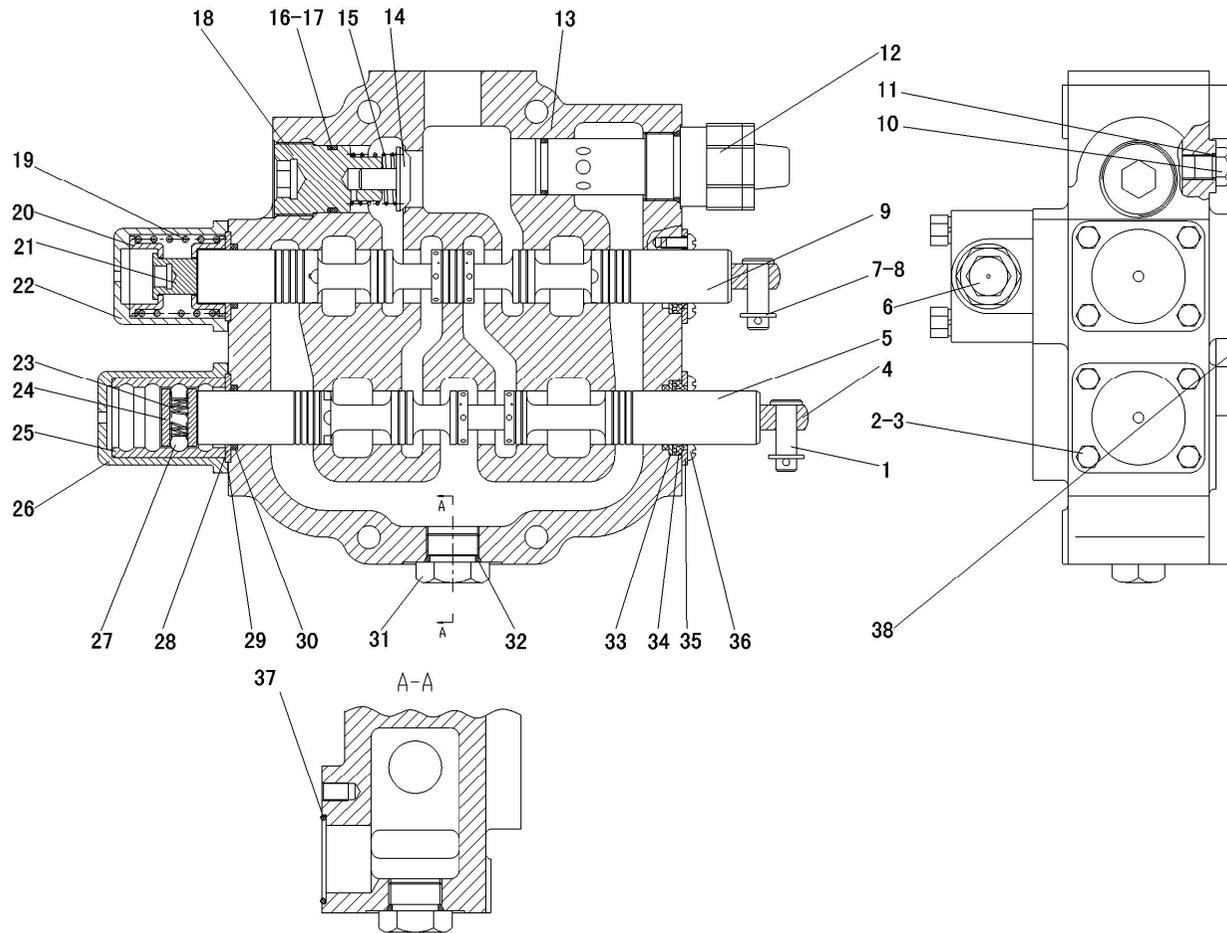

序号 Key	零件代号 Part No.	名称 Description	是否配件 Spare parts Y/N	数量 Qty	备注 Remarks	
23	4120002038016	弹簧DFS-32-09	SPRING DFS-32-09	Y	1	
24	4120002038017	钢球座DFS-32-10	SEAT DFS-32-10	N	1	
25	4120002038018	定位衬套DFS-32III-04	BUSH DFS-32III-04	N	1	
26	4120002038019	定位外套DFS-32III-05	BUSH DFS-32III-05	N	1	
27	4120002038020	钢球GB308-10-GCr15	STEEL BALL GB308-10-GCr15	N	2	
28	4120002038021	压板DFS-32-13	PRESS PLATE DFS-32-13	N	2	
29	4120002038022	密封垫DFS-32-14	SEAL WASHER DFS-32-14	Y	2	
30	4120002038023	O形圈（派克2-217）29.74*3.53	O-RING 29.74*3.53	Y	4	
31	4120000703019	螺塞DF-32-20	PLUG DF-32-20	N	1	
32	4030000013	O形圈GB1235-32*3.1	O-RING GB1235-32*3.1	Y	1	
33	4120002038024	隔板DFS-32-15	BAFFLE DFS-32-15	N	2	
34	4120002038025	CK30防尘圈DFS-32-16	WIPER SCRAPER SEA DFS-32-16	Y	2	
35	4120002038026	压板DFS-32-17	PLATE DFS-32-17	N	2	
36	4120000703029	螺钉GB67-M6*12	SCREW GB67-M6*12	N	8	
37	4030000760	O形圈GB1235-50*3.1	O-RING GB1235-50*3.1	Y	1	
38	4120002038030	螺塞DFS-32-18	PLUG SCREW DFS-32-18	N	2	



**H 工作装置**  
**WORKING EQUIPMENT**

山东临工工程机械有限公司  
**SHANDONG LINGONG CONSTRUCTION MACHINERY CO.,LTD.**

工作装置 WORKING EQUIPMENT

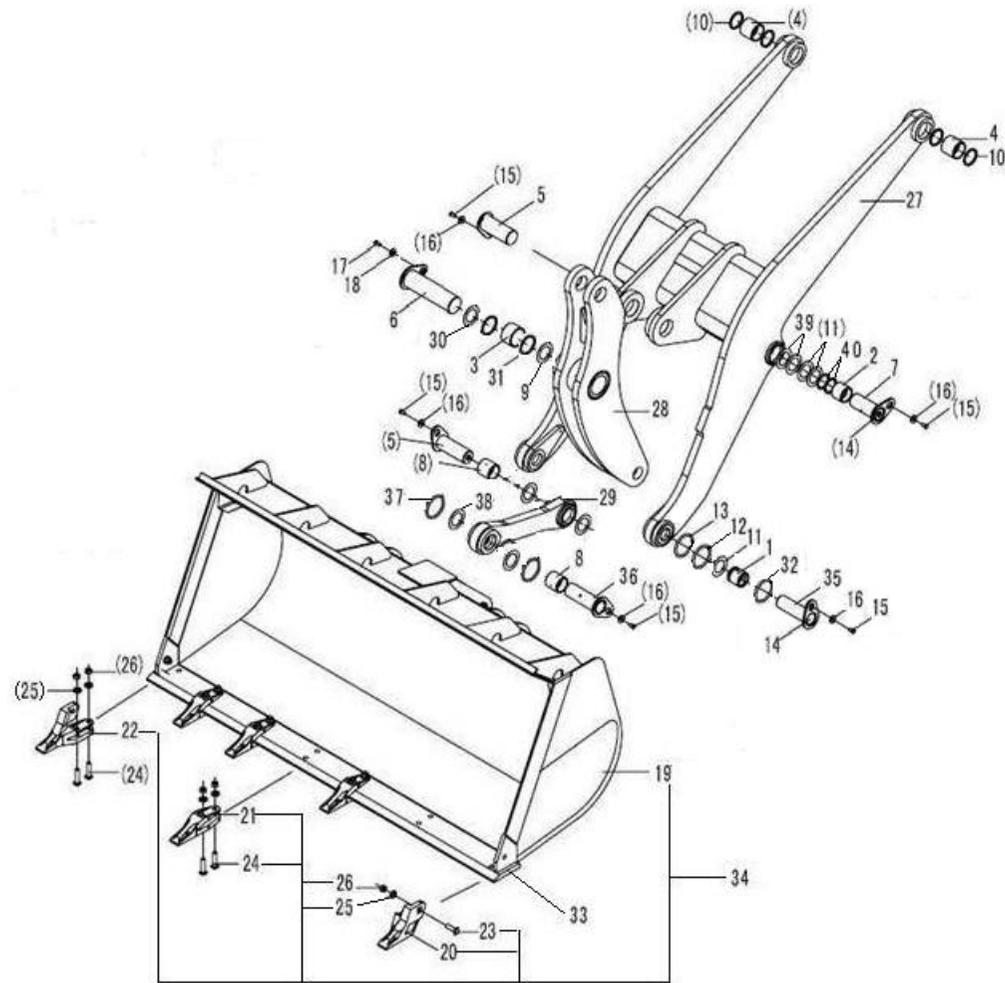

序号 Key	零件代号 Part No.	名称 Description	是否配件 Spare parts Y/N	数量 Qty	备注 Remarks
1	4043000122	轴套LGB302-60*60A2 BUSHING	Y	2	
2	4043000423	轴套LGB302-60*50A2 SHAFT SLEEVE LGB302-60*50A2	Y	2	
3	4043000419	轴套LGB302-100*137A2 SHAFT SLEEVE LGB302-100*137A2	Y	1	
4	4043000439	轴套LGB302-85*80C2 SHAFT SLEEVE LGB302-85*80C2	Y	2	
5	4043000418	销轴LGB301-70*100*185-40Cr PIN LGB301-70*100*185-40Cr	Y	2	
6	4043000420	销轴LGB301-100*148*280/2-40Cr PIN LGB301-100*148*280/2-40Cr	Y	1	
7	4043000119	销轴LGB301-60*85*150-40Cr PIN LGB301-60*85*150-40Cr	Y	2	
8	4043000421	轴套LGB302-70*60A2 SHAFT SLEEVE LGB302-70*60A2	Y	2	
9	4043000354	垫片LGB303-100*180*2 SHIM	Y	1	
10	4043000056	防尘圈LGB307-85 PUSTRING LGB307-85	Y	4	
11	4043000127	防尘圈LGB307-60 PUSTRING LGB307-60	Y	8	
12	4043000126	垫片LGB303-60*100*2 WASHER LGB303-60*100*2	Y	2	
13	4043000129	O形圈LGB308-98*8 O-RING LGB308-98*8	Y	4	
14	4030000065	油杯JB7940.1-M10*1 GREASE NIPPLE JB7940.1-M10*1	Y	8	
15	4011000197	螺栓GB5783-M12*25EpZn-8.8 BOLT GB5783-M12*30EpZn-8.8	N	7	
16	4040000001	垫圈LGB001-12 WASHER LGB001-12*45*6	Y	7	
17	4011000094	螺栓GB5783-M16*30EpZn-8.8 BOLT GB5783-M16*30EpZn-8.8	N	1	
18	4040000002	垫圈LGB001-16 WASHER LGB001-16	Y	1	
19	29170037991	铲斗 BUCKET	Y	1	
20	29170036981	左边齿 LEFT SIDE BUCKET TEETH	Y	1	
21	29170036971	斗齿 BUCKET TEETH	Y	5	
22	29170036961	右边齿 RIGHT SIDE BUCKET TEETH	Y	1	

工作装置 WORKING EQUIPMENT

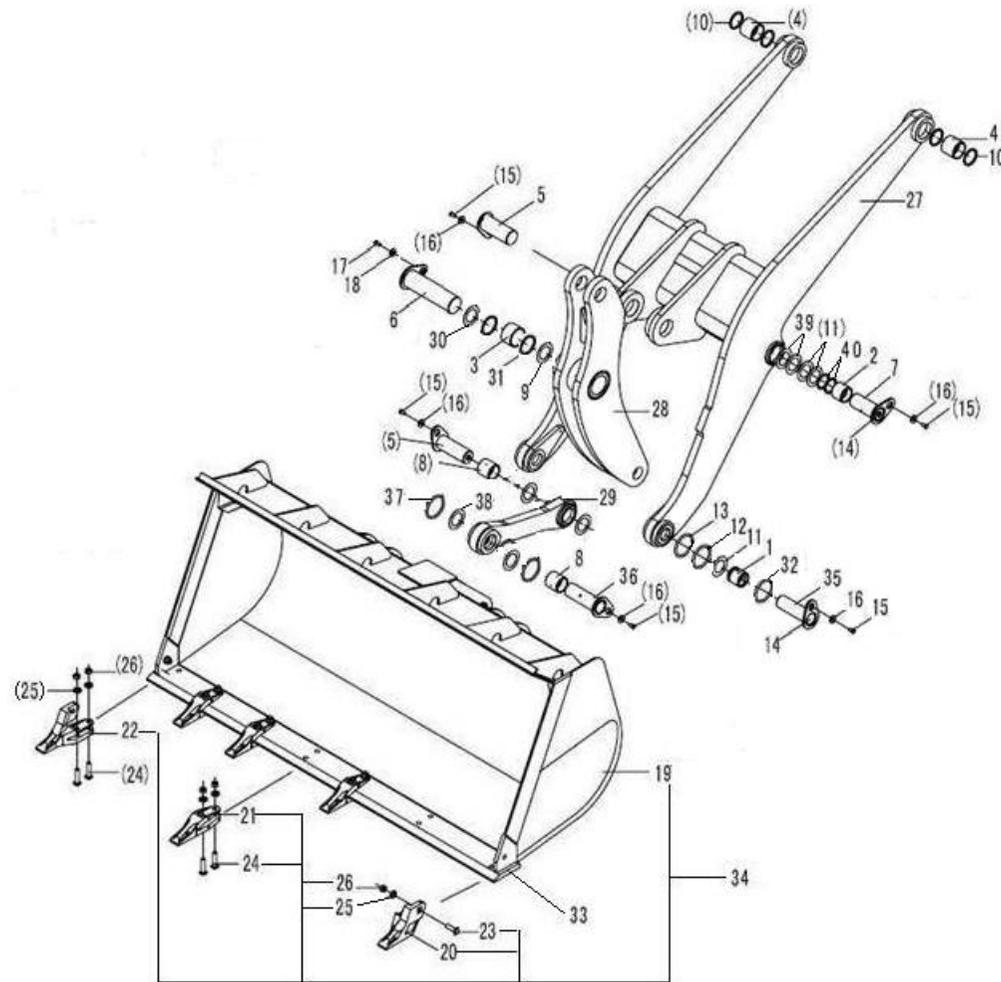

序号 Key	零件代号 Part No.	名称 Description	是否配件 Spare parts Y/N	数量 Qty	备注 Remarks
23	4043000337	螺栓LGB002-M16*50	BOLT LGB002-M16*50	Y	2
24	4040000011	螺栓LGB002-M16*75	BOLT LGB002-M16*75	Y	14
25	4015000001	垫圈GB1230-16EpZn-45	WASHER GB1230-16EpZn-45	N	16
26	4013000016	螺母GB6170-M16EpZn-8	NUT GB6170-M16EpZn-8	N	16
27	29150010231	动臂	ARM	Y	1
28	29150010321	摇臂	ROCKER	Y	1
29	29150010371	连杆	ROD	Y	1
30	4043000353	垫片LGB303-100*180*1	SHIM	Y	1
31	4043000095	防尘圈LGB307-100	DUSTPROOF RING	Y	2
32	4043000125	垫片LGB303-60*100*1	SPACER LGB303-60*100*1	Y	2
33	29170038141	主刀板	PLATE	N	1
34	29170037981	铲斗总成	BUCKET	Y	1
35	4043000112	销轴LGB301-60*95*170-40Cr	PIN LGB301-60*95*170G-40Cr	Y	2
36	4043000346	销轴LGB301-70*95*170-40Cr	PIN	Y	1
37	4043000350	O型圈LGB308-108*8	O-RING	Y	2
38	4043000349	防尘圈LGB307-70	DUSTPROOF RING	Y	4
39	4043000141	垫片LGB303-60*120*2	SPACER LGB303-60*120*2	Y	2
40	4043000151	垫片LGB303-60*120*1	SPACER LGB303-60*120*1	Y	2



# I 转向系统

## **STEERING SYSTEM**

山东临工工程机械有限公司  
**SHANDONG LINGONG CONSTRUCTION MACHINERY CO.,LTD.**

转向泵总成 STEERING PUMP ASSEMBLY

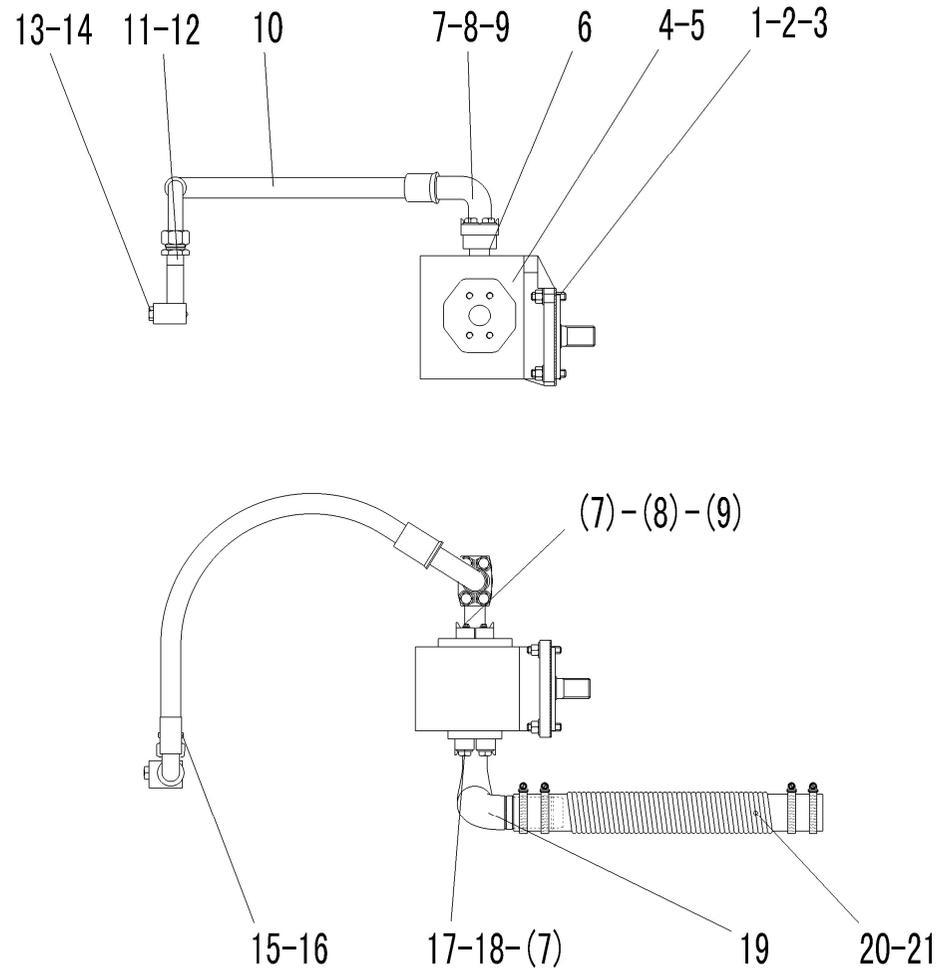

序号 Key	零件代号 Part No.	名称 Description	是否配件 Spare parts Y/N	数量 Qty	备注 Remarks
1	4012000003	螺柱GB898-M12*35EpZn-8.8	DOUBLE-SCREW BOLT GB898-M12*35EpZn-8.8	N	4
2	4015000168	垫圈GB97.1-12EpZn-300HV	WASHER GB97.1-12EpZn-300HV	N	4
3	4013000011	螺母GB6170-M12EpZn-8	NUT GB6170-M12 EpZn-8	N	4
4	4120002117	齿轮泵CBGj2063A	GEAR PUMP CBGj2063A	Y	1
5	29110000041	泵用密封垫	SEALING WASHER	Y	1
6	29190004121	转向泵出油钢管	OUTLET PIPE OF STEERING PUMP	Y	1
7	4011000475	螺栓GB16674-M10*30EpZn-8.8	BOLT GB16674-M10*30EpZn-8.8	N	12
8	4041000026	分体法兰LGB117-310491	FLANGE LGB117-310491	Y	2
9	4030000026	O形圈GB3452.1-32.5*3.55G	O-RING GB3452.1-32.5*3.55G	Y	2
10	29190004131	转向泵至优先阀胶管	PIPE	Y	1
11	29190004141	优先阀进油钢管	INLET TUBE OF PRIOPTRY VALVE	Y	1
12	4030000241	O形圈GB3452.1-20.0*1.80G	O-RING GB3452.1-20.0*1.80G	Y	1
13	4041000774	螺塞LGB135-01422	PLUG LGB13501421	Y	1
14	4041000767	O形圈LGB168-11124	O-RING LGB168-11124	Y	1
15	4041000188	直接头LGB120-03028	JOINT LGB120-03028	Y	1
16	4041000779	O形圈LGB168-12331	O-RING LGB168-12331	Y	1
17	4030000028	O形圈GB3452.1-36.5*3.55G	O-RING GB3452.1-36.5*3.55G	Y	1
18	4041000056	分体法兰LGB117-312550	FLANGE LGB117-312550	Y	1
19	29190004051	转向泵吸油钢管	OIL INLET TUBE OF STEERING PUMP	Y	1
20	4090000043	吸油胶管 HG4-763-45*450	OIL INLET PIPE HG4-763-45*450	Y	1
21	4017000007	喉箍JB8870-d60	CLAMP JB8870-d60	N	4

转向器总成 STEERING GEAR

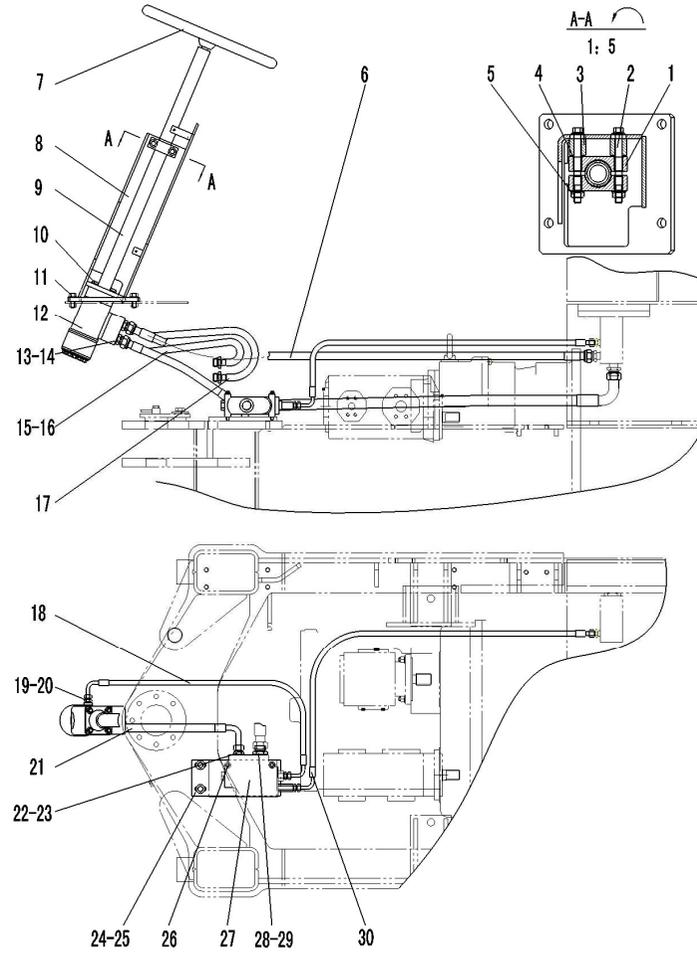

序号 Key	零件代号 Part No.	名称 Description	是否配件 Spare parts Y/N	数量 Qty	备注 Remarks
1	29310011251	固定板	Y	2	
2	4011000528	螺栓GB16674-M10*100EpZn-8.8	N	2	
3	29310011301	调整座	Y	2	
4	4015000162	垫圈GB97.1-10EpZn-300HV	N	6	
5	4013000007	螺母GB6170-M10EpZn-8	N	2	
6	4041000516	软管LGB164-010150	Y	1	
7	4120000018	方向盘FXP-50F	Y	1	
8	29310011191	固定架	Y	1	
9	4120001855	转向柱LG20-ZXZ-09	Y	1	
10	4011000473	螺栓GB16674-M10*55EpZn-8.8	N	4	
11	4011000479	螺栓GB16674-M12*30EpZn-8.8	N	4	
12	4120002379	转向器BZZ6-500	Y	1	
13	4041000564	直接头LGB120-02620	Y	4	
14	4041000783	O形圈LGB168-11724	Y	4	
15	29200004021	转向器出油钢管A	Y	1	
16	4030000501	O形圈GB3452.1-15.0*1.80G	Y	2	
17	29200004031	转向器出油钢管B	Y	1	
18	29200007781	优先阀反馈油管	Y	1	
19	4041000131	直接头LGB120-01412	Y	3	
20	4041000784	O形圈LGB168-10924	Y	3	
21	29200008251	转向器进油胶管	Y	1	
22	4041000187	直接头LGB120-02622	Y	1	

转向器总成 STEERING GEAR

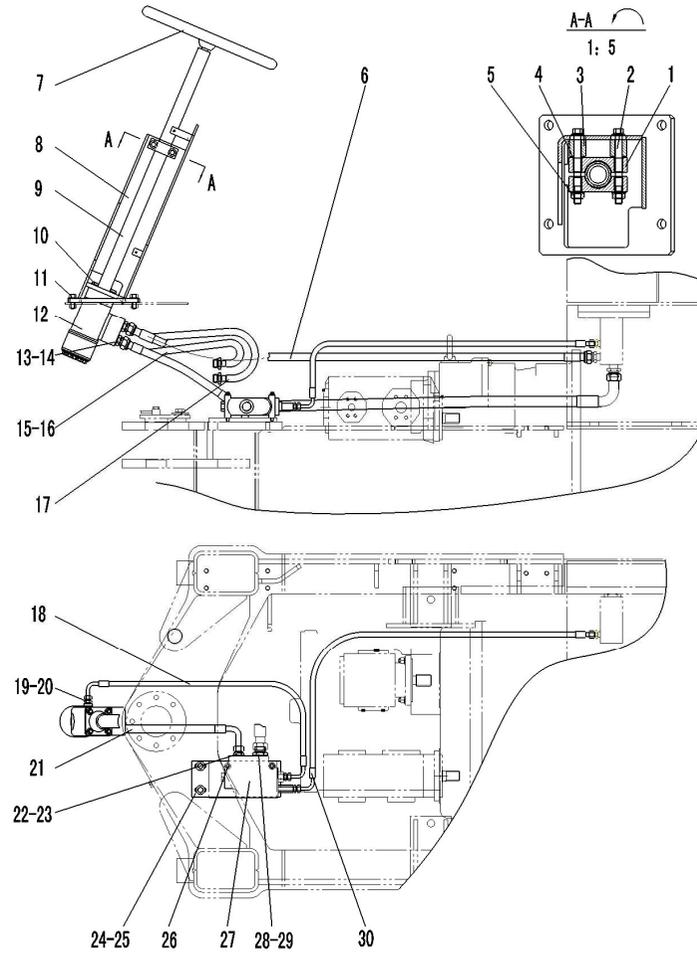

序号 Key	零件代号 Part No.	名称 Description	是否配件 Spare parts Y/N	数量 Qty	备注 Remarks
23	4041000771	O形圈LGB168-11924	O-RING LGB168-11924	Y	1
24	29200008461	固定板	MOUNTING PLATE	Y	1
25	4011000560	螺栓GB16674-M12*25EpZn-8.8	BOLT GB16674-M12*25EpZn-8.8	N	2
26	4011000302	螺栓GB16674-M8*75EpZn-8.8	BOLT GB16674-M8*75EpZn-8.8	N	2
27	4120002518	优先阀VLE-150-14	PRIORITY VALVE VLE-150-14	Y	1
28	4041000188	直接头LGB120-03028	JOINT LGB120-03028	Y	1
29	4041000779	O形圈LGB168-12331	O-RING LGB168-12331	Y	1
30	4041000514	软管LGB165-003121	PIPE LGB165-003121	Y	1



转向缸总成 STEERING CYLINDER ASSEMBLY

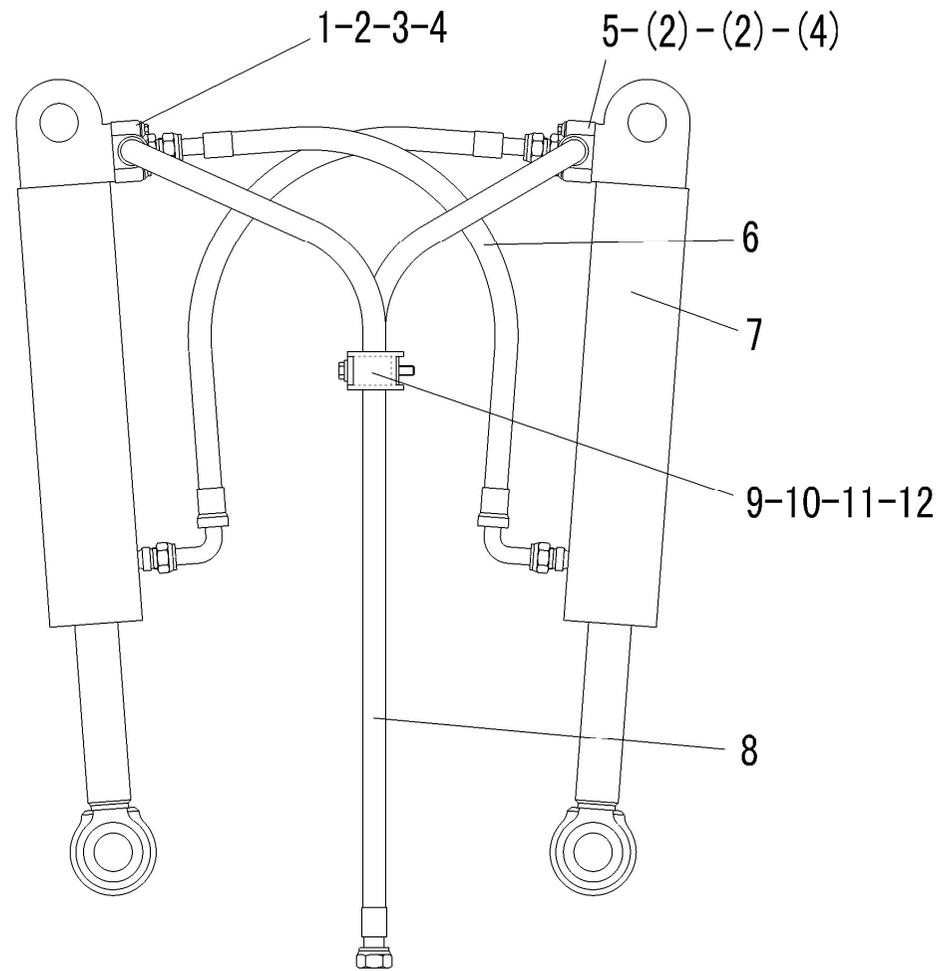

序号 Key	零件代号 Part No.	名称 Description	是否配件 Spare parts Y/N	数量 Qty	备注 Remarks	
1	29210004081	钢管	TUBE	Y	1	
2	4030000275	O形圈GB3452.1-22.4*3.55G	O-RING GB3452.1-22.4*3.55G	Y	2	
3	4011000481	螺栓GB16674-M8*30EpZn-8.8	BOLT GB16674-M8*30Ep.Zn-8.8	N	4	
4	4011000277	螺栓GB16674-M8*40EpZn-8.8	BOLT GB16674-M8*40EpZn-8.8	N	4	
5	29210004091	钢管	TUBE	Y	1	
6	4041000563	软管LGB128-006078	PIPE LGB128006078	Y	2	
7	4120001004	转向油缸HSGL-80*45*327-594	STEERING CYLINDER HSGL-80*45*327-594	Y	2	
8	29210007661	转向缸进油胶管	OIL INLET PIPE OF STEERING CYLINDER	Y	2	
9	29210004061	固定座	PERMAMENT SEAT	Y	1	
10	29210004071	橡胶板	RUBBER BAR	Y	2	
11	4011000051	螺栓GB5782-M10*70EpZn-8.8	BOLT GB5782-M10*70EpZn-8.8	N	1	
12	4015000197	垫圈GB96.1-10EpZn-300HV	WASHER GB96.1-10EpZn-300HV	N	1	

转向油缸 (371401) STEERING CYLINDER (371401)

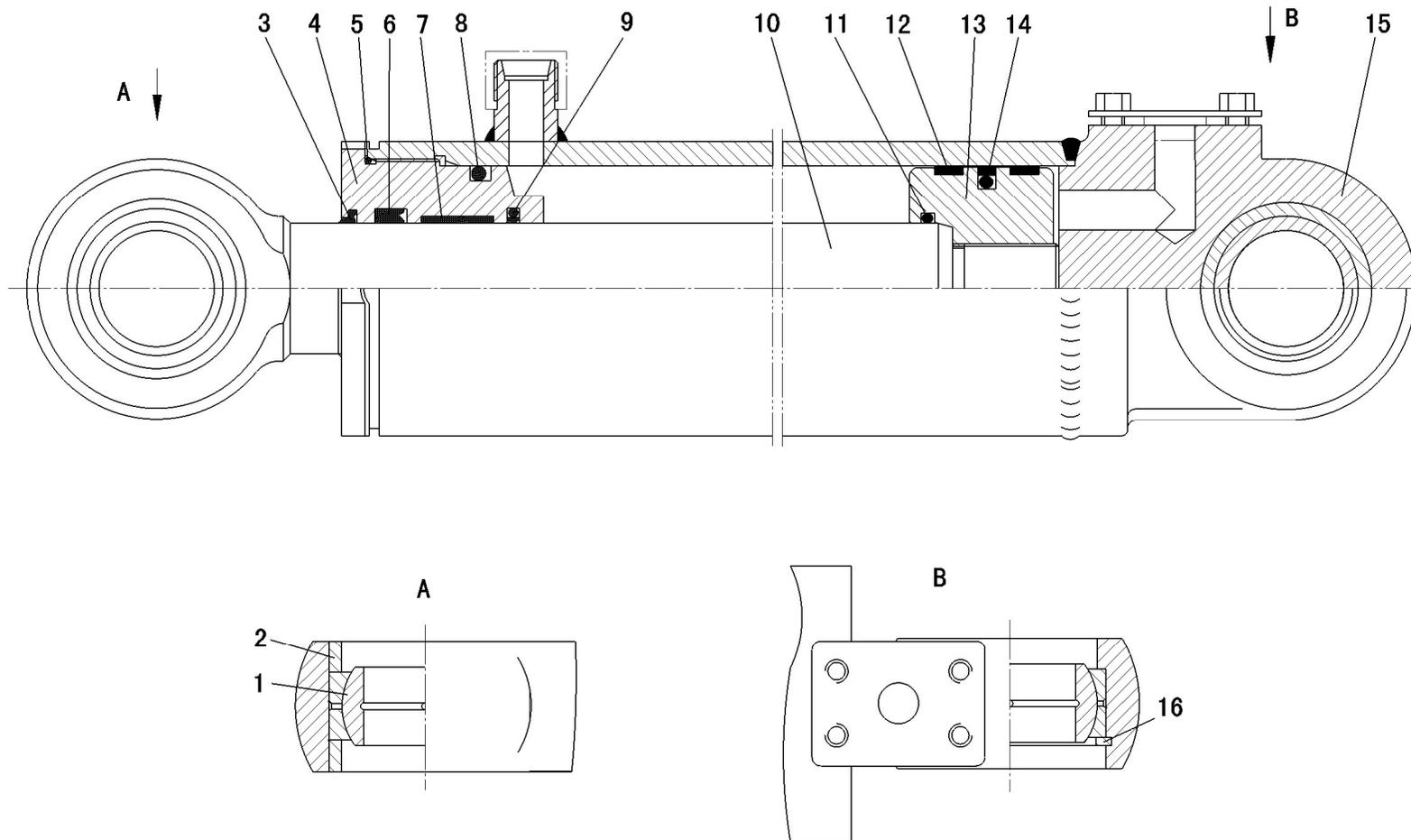

序号 Key	零件代号 Part No.	名称 Description	是否配件 Spare parts Y/N	数量 Qty	备注 Remarks	
1	4120001004009	关节轴承	SPHERICAL PLAIN BEARING	Y	2	
2	4120001004010	挡环	HOLDING BLOCK	N	2	
3	4120001004007	密封件包	SEALING MEMBER AGGREGATE	Y	1	
4	4120001004016	缸盖	CYLINDER COVER	N	1	
5	4120001004007	密封件包	SEALING MEMBER AGGREGATE	Y	1	
6	4120001004007	密封件包	SEALING MEMBER AGGREGATE	Y	1	
7	4120001004007	密封件包	SEALING MEMBER AGGREGATE	Y	1	
8	4120001004007	密封件包	SEALING MEMBER AGGREGATE	Y	1	
9	4120001004007	密封件包	SEALING MEMBER AGGREGATE	Y	1	
10	4120001004019	活塞杆	PISTON ROD	Y	1	
11	4120001004007	密封件包	SEALING MEMBER AGGREGATE	Y	1	
12	4120001004007	密封件包	SEALING MEMBER AGGREGATE	Y	2	
13	4120001004012	活塞	PISTON	N	1	
14	4120001004007	密封件包	SEALING MEMBER AGGREGATE	Y	1	
15	4120001004008	缸体	CYLINDER BODY	N	1	
16	4015000261	挡圈GB893.1-62-65Mn	CHECK RING GB893.1-62-65Mn	N	1	

转向油缸 (371368) STEERING CYLINDER (371368)

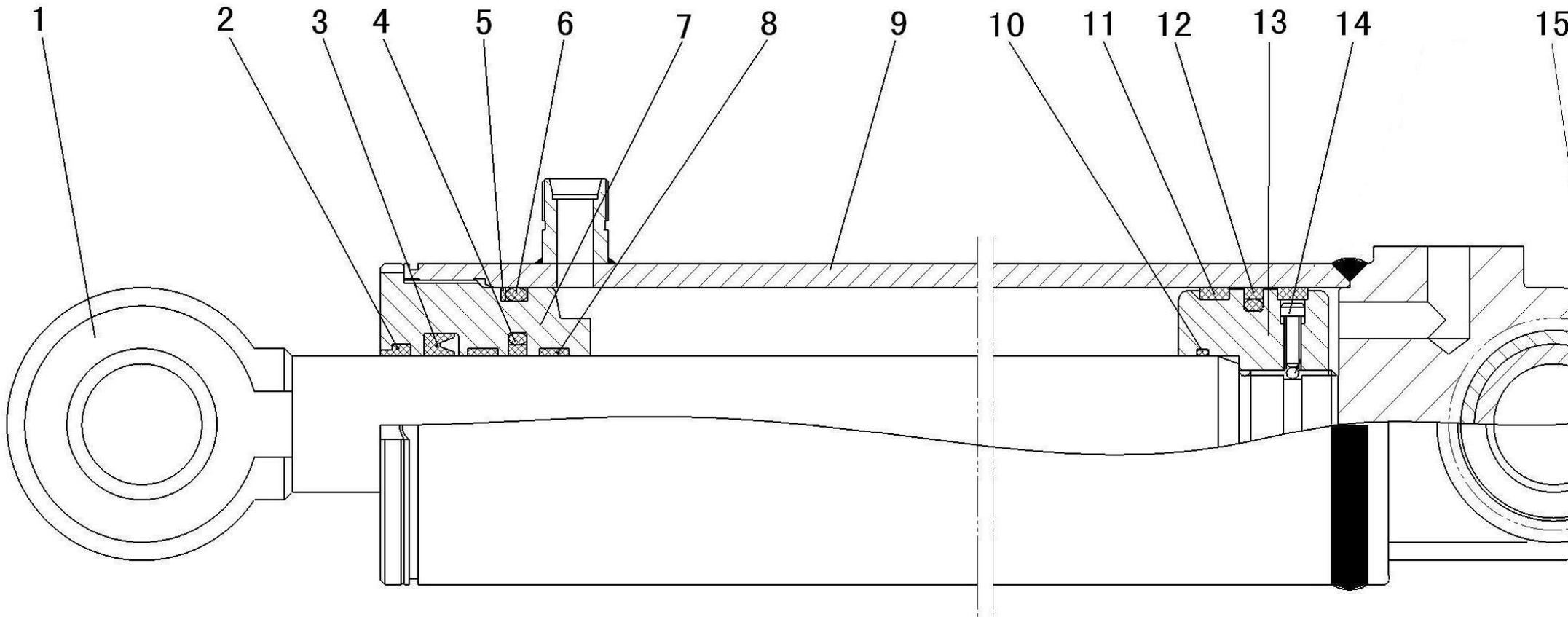

序号 Key	零件代号 Part No.	名称 Description	是否配件 Spare parts Y/N	数量 Qty	备注 Remarks
1	4120001004113	活塞杆HSGL-80/45*327-1	PISTON ROD HSGL-80/45*327-1	Y	1
2	4120001004101	密封件包	SEALING MEMBER AGGREGATE	Y	1
3	4120001004101	密封件包	SEALING MEMBER AGGREGATE	Y	1
4	4120001004101	密封件包	SEALING MEMBER AGGREGATE	Y	1
5	4120001004101	密封件包	SEALING MEMBER AGGREGATE	Y	1
6	4120001004101	密封件包	SEALING MEMBER AGGREGATE	Y	1
7	4120001004110	导向套HSGL-80/45*327-2	CYLINDER COVER HSGL-80/45*327-2	N	1
8	4120001004101	密封件包	SEALING MEMBER AGGREGATE	Y	2
9	4120001004104	缸体HSGL-80/45*327-3	CYLINDER BODY HSGL-80/45*327-3	N	1
10	4120001004101	密封件包	SEALING MEMBER AGGREGATE	Y	1
11	4120001004101	密封件包	SEALING MEMBER AGGREGATE	Y	2
12	4120001004101	密封件包	SEALING MEMBER AGGREGATE	Y	1
13	4120001004109	活塞HSGL-80/45*327-4	PISTON HSGL-80/45*327-4	N	1
14	4014000237	螺钉GB70.1-M6*16-8.8	SCREW GB70.1-M6*16-8.8	N	1
15	4021000199	轴承GB9163-GE40ES	SPHERICAL PLAIN BEARING	Y	2
16	4015000261	挡圈GB893.1-62-65Mn	CHECK RING GB893.1-62-65Mn	N	1



**J 制动系统**  
**BRAKE SYSTEM**

山东临工工程机械有限公司  
**SHANDONG LINGONG CONSTRUCTION MACHINERY CO.,LTD.**

行车制动总成 SERVICE BRAKE SYSTEM

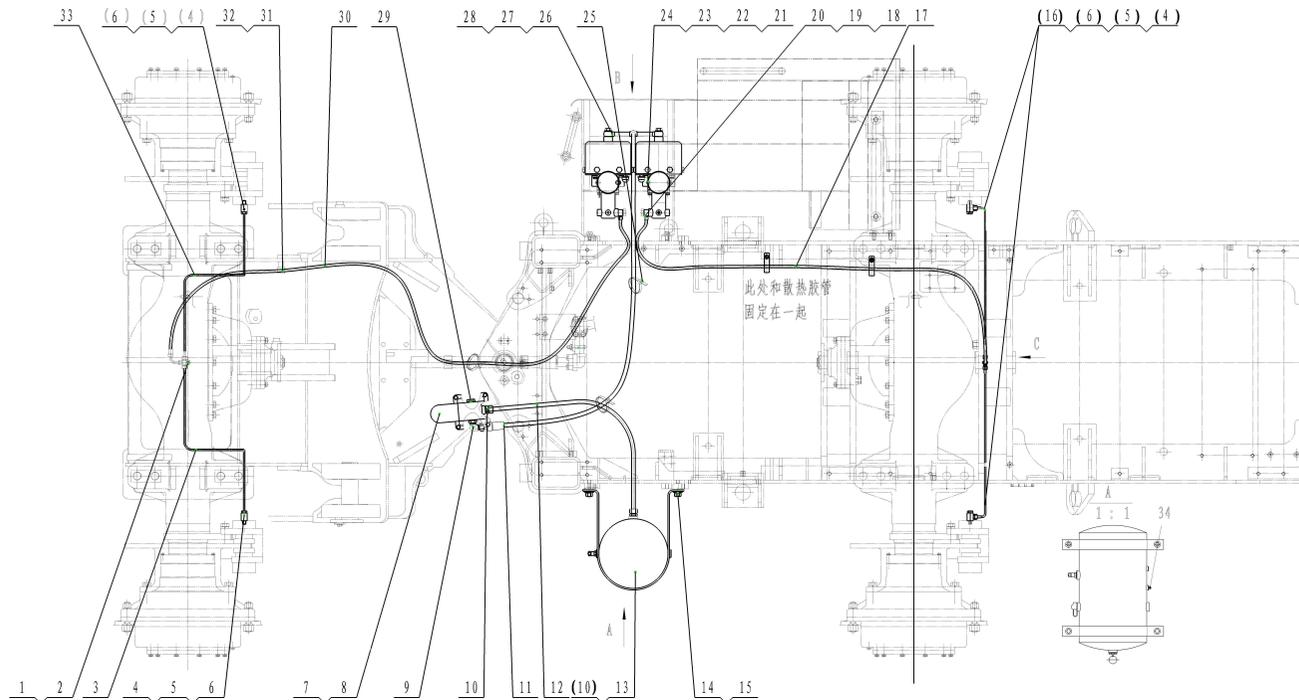

序号 Key	零件代号 Part No.	名称 Description	是否配件 Spare parts Y/N	数量 Qty	备注 Remarks
1	29220000131	三通接头	CONNECTOR	Y	2
2	4011000455	螺栓GB16674-M8*25EpZn-8.8	BOLT GB16674-M8*25EpZn-8.8	N	6
3	29220009931	前桥左油管	STEEL TUBE	Y	1
4	4030000552	O形圈	O-RING	Y	8
5	29220001261	制动器接头块	ARRESTER CONNECTOR	Y	4
6	29220001251	制动器管接头	CONNECTOR	Y	4
7	4120001795	气制动阀LY60F	BRAKE CONTROL VALVE LY60F	Y	1
8	4130000521	制动灯开关YK209K	SWITCH OF BRAKE LIGHT	Y	1
9	29220001201	弯接头总成	JOINT	Y	1
10	29220001191	直接头	CONNECTOR	Y	2
11	4041001237	软管LGB145-205165	HOSE LGB146-205180	Y	1
12	4041001228	软管LGB146-205108	HOSE LGB146-205108	Y	1
13	29220000531	储气罐	AIR RESERVOIR	Y	1
14	4011000197	螺栓GB5783-M12*25EpZn-8.8	BOLT GB5783-M12*30EpZn-8.8	N	4
15	4015000186	垫圈GB96.1-12EpZn-300HV	WASHER GB96.1-12EpZn-300HV	N	4
16	29220009971	后桥油管	OIL PIPE	Y	2
17	4041001522	软管LGB153-202250	HOSE LGB153-202250	Y	1
18	29220001231	加力泵管接头	CONNECTOR	Y	2
19	4030000551	O形圈	O-RING	Y	4
20	29220001241	加力泵接头块	JOINT BLOCK	Y	2
21	4120000090	加力泵XZ-60	BOOSTER XZ-60	Y	2
22	4011000082	螺栓GB5783-M10*25EpZn-8.8	BOLT GB5783-M10*25EpZn-8.8	N	4

行车制动总成 SERVICE BRAKE SYSTEM

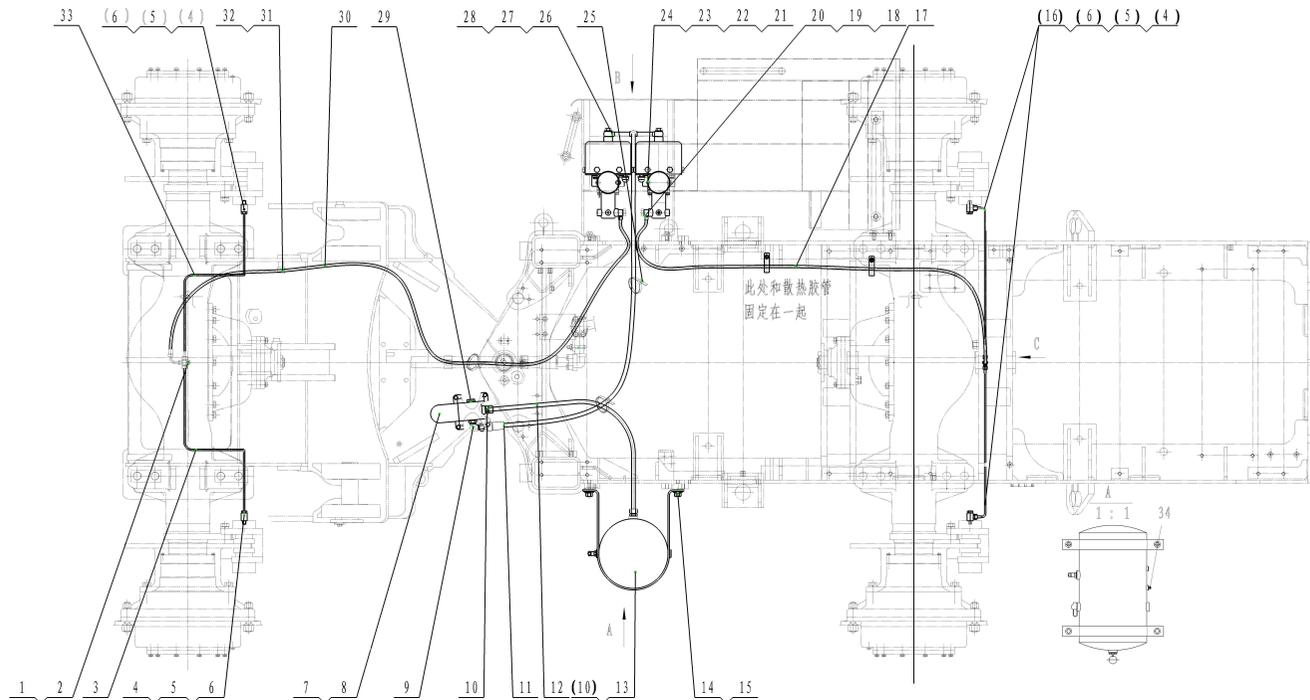

序号 Key	零件代号 Part No.	名称 Description	是否配件 Spare parts Y/N	数量 Qty	备注 Remarks	
23	4015000322	垫圈GB97.1-10-300HV	WASHER GB97.1-10-300HV	N	4	
24	4013000007	螺母GB6170-M10EpZn-8	NUT GB6170-M10EpZn-8	N	4	
25	4190000020	扎丝LG13-ZS4*250	CLIP LG13-ZS4*250	Y	5	
26	29010000041	螺栓	BOLT	Y	2	
27	29220000811	垫圈	WASHER	Y	4	
28	29220000821	三通管	TEE OF THE OIL LINE	Y	1	
29	4030000055	螺塞JB1000-M22*1.5EpZn-35	PLUG JB1000-M22*1.5-35	Y	1	
30	4041001183	软管LGB153-202310	HOSE LGB153-202310	Y	1	
31	4011000461	螺栓GB16674-M8*16EpZn-8.8	BOLT GB16674-M8*16EpZn-8.8	N	2	
32	29010000031	管夹	CLAMP	Y	2	
33	29220009951	前桥右油管	STEEL TUBE	Y	1	
34	4030000311	螺塞JB1000-M10*1EpZn-35	PLUG JB1000-M10*1EpZn-35	Y	1	

储气罐 AIR RESERVOIR

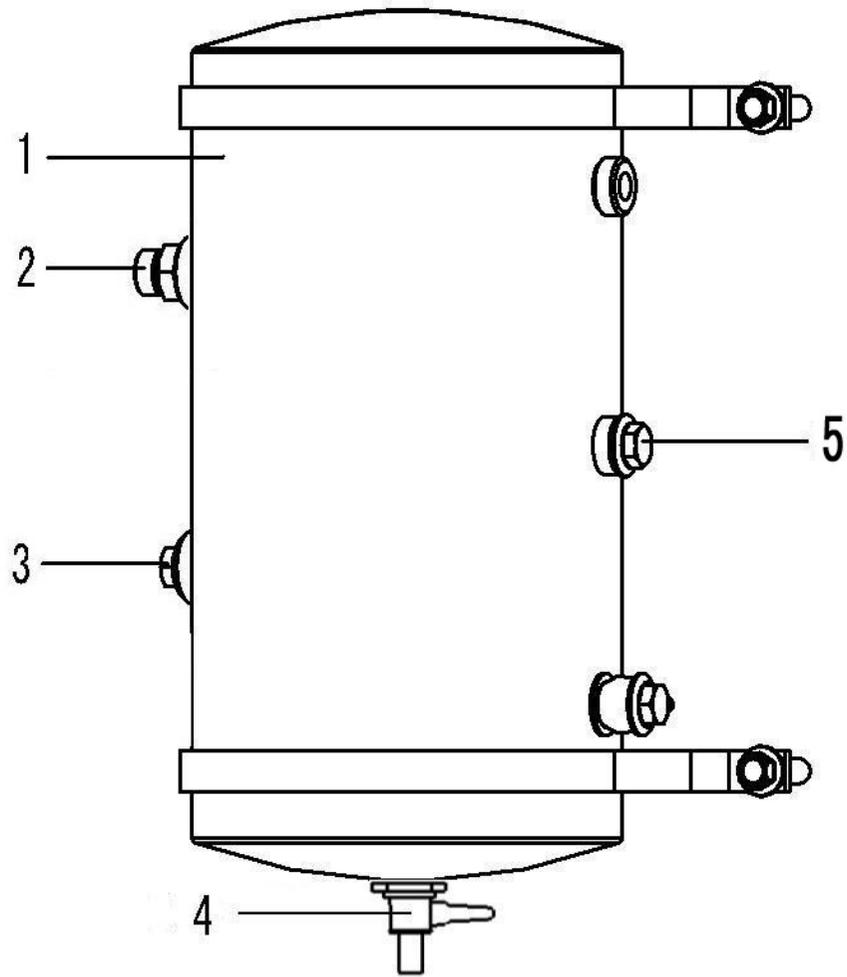

序号 Key	零件代号 Part No.	名称 Description	是否配件 Spare parts Y/N	数量 Qty	备注 Remarks	
1	29220000541	罐体	AIR RESERVOIR BODY	Y	1	
2	4120000065	安全阀LG09-AQF	SAFETY VALVE	Y	1	
3	4120000742	轮胎充气阀LG09-CQF	CHARGE VALVE FOR TIRE	Y	1	
4	4120000066	791手动放水阀LG09-FSF	791-WATER DRAIN VALVE	Y	1	
5	4030000311	螺塞JB1000-M10*1EpZn-35	PLUG JB1000-M10*1EpZn-35	Y	1	



加力泵(340201) BRAKE BOOSTER

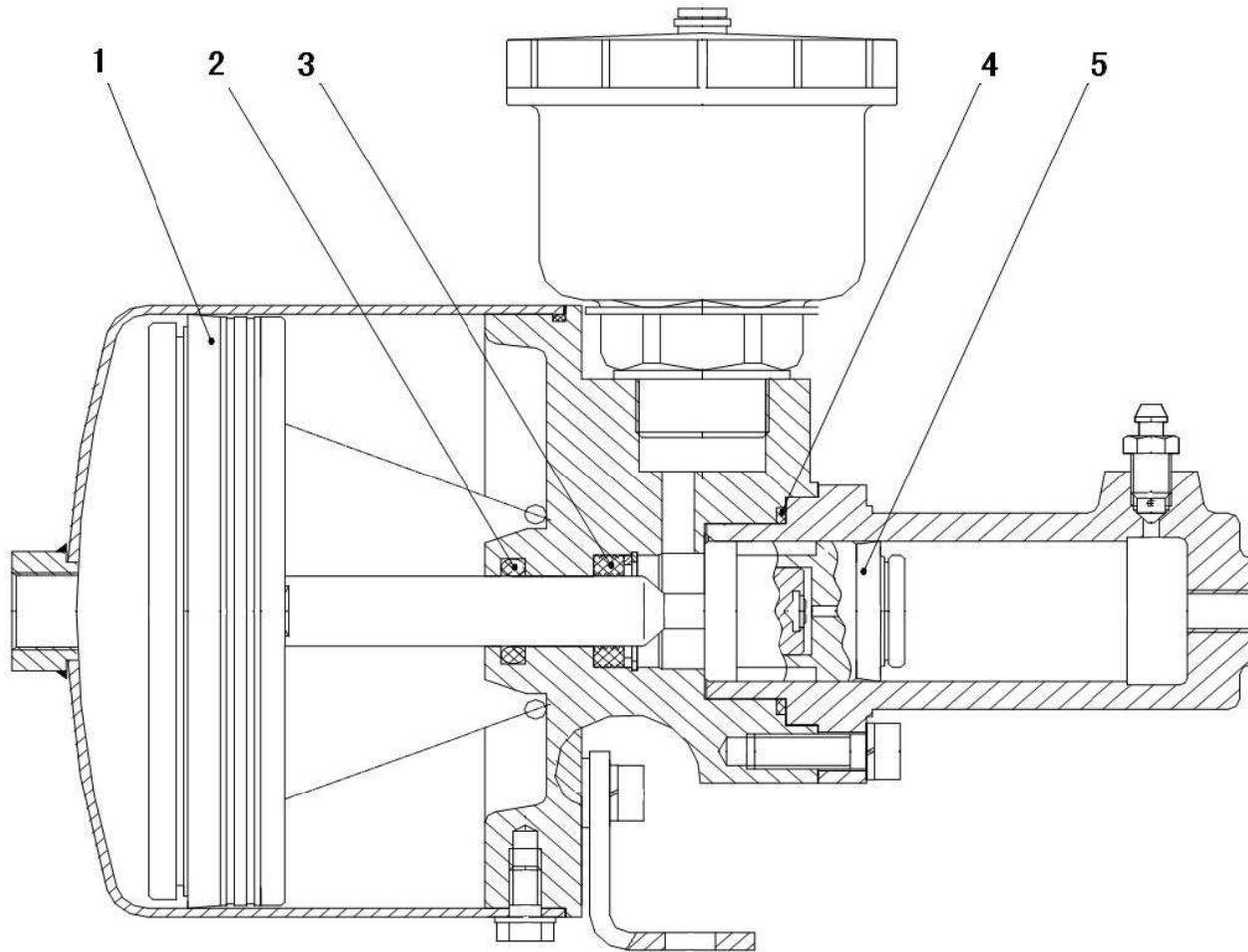

序号 Key	零件代号 Part No.	名称 Description	是否配件 Spare parts Y/N	数量 Qty	备注 Remarks
1	4120000090051	密封件包	Y	1	
2	4120000090051	密封件包	Y	1	
3	4120000090051	密封件包	Y	1	
4	4120000090051	密封件包	Y	1	
5	4120000090051	密封件包	Y	1	



驻车制动系统 PARKING BRAKE SYSTEM

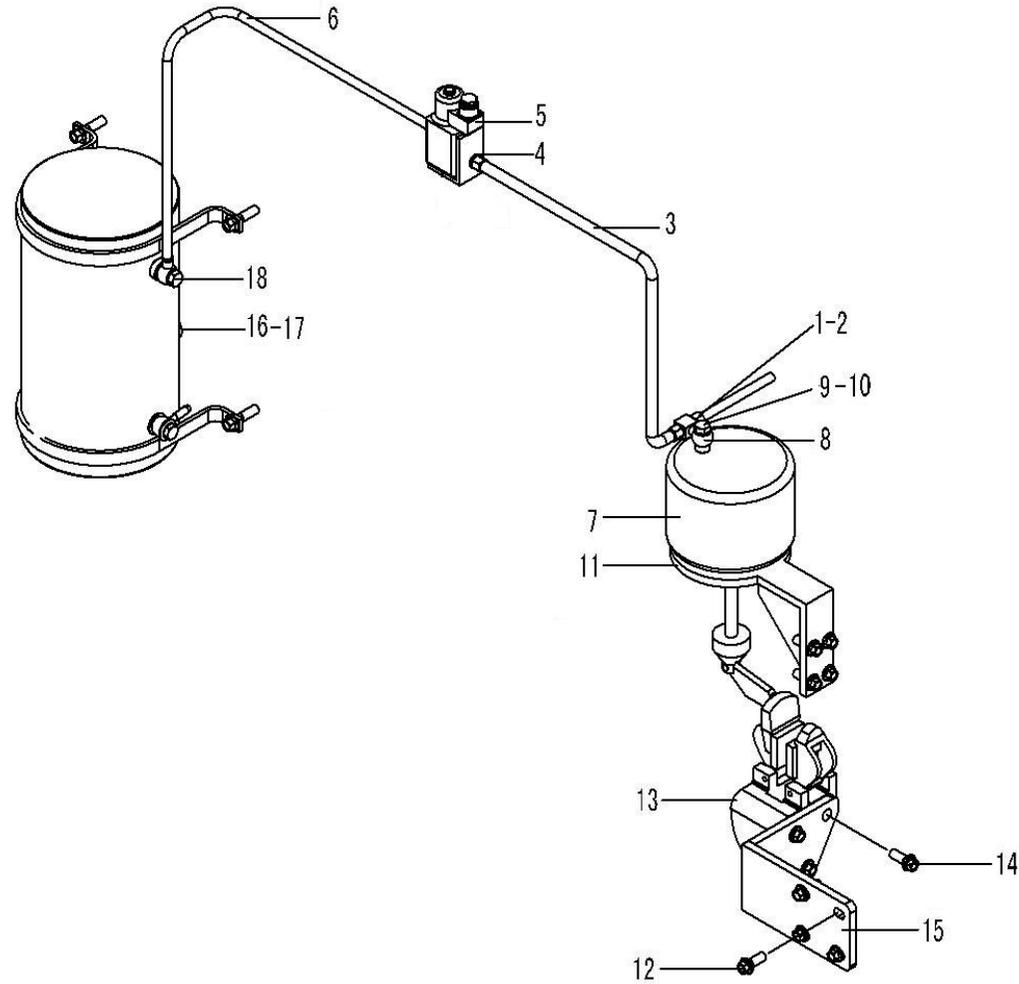

序号 Key	零件代号 Part No.	名称 Description	是否配件 Spare parts Y/N	数量 Qty	备注 Remarks	
1	4130000055	气压信号灯开关HFF-3757002	SWITCH	Y	1	
2	29010000051	垫圈	WASHER	Y	1	
3	29230000211	驻车制动气室气管	PIPE	Y	1	
4	29230000121	接头体	CONNECTER	Y	2	
5	4120000759	制动电磁阀LG23-DCF	BRAKE VALVE	Y	1	
6	29230000131	电磁阀进气管	PIPE	Y	1	
7	4120000506	驻车制动气室	AIR RESERVOIR	Y	1	
8	29230000151	三通块	THREE-WAY PIPE	Y	1	
9	4011000339	螺栓JB999-M14*1.5*28EpZn-35	BOLT JB999-M14*1.5*28-35	Y	1	
10	29230000031	垫圈	WASHER	Y	2	
11	29230004021	支架	BRACKET	Y	1	
12	4011000479	螺栓GB16674-M12*30EpZn-8.8	BOLT GB16674-M12*30EpZn-8.8	N	8	
13	4120000087	手制动器TC5Z	HAND BRAKE TC5Z	Y	1	
14	4011000148	螺栓GB16674-M16*40EpZn-8.8	BOLT GB16674-M16*40EpZn-8.8	N	3	
15	29230001051	支架	BRACKET	Y	1	
16	4120000760	压力开关LY-3720002	SWITCH	Y	1	
17	29220009121	垫圈	WASHER	Y	3	
18	29220009111	螺栓	BOLT	Y	1	

气制动阀 (330604) BRAKE CONTROL VALVE (330604)

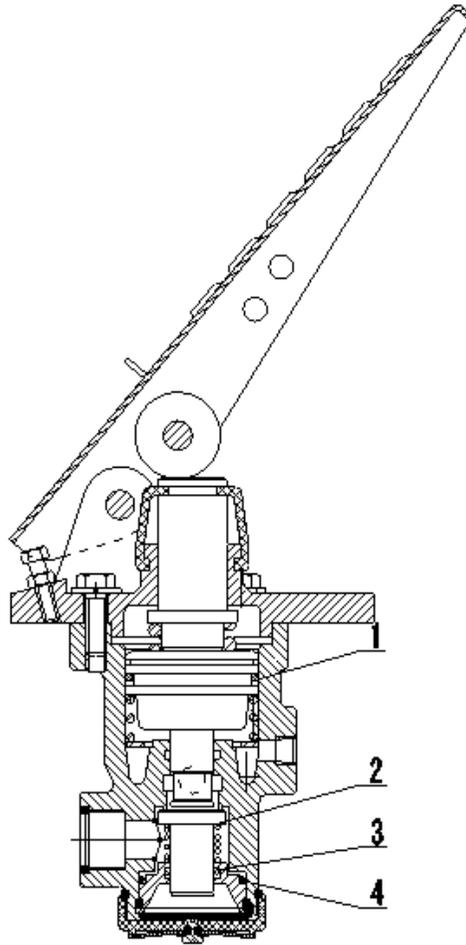

序号 Key	零件代号 Part No.	名称 Description	是否配件 Spare parts Y/N	数量 Qty	备注 Remarks	
1	4120001795002	O形圈	O-RING	Y	1	
2	4120001795003	下阀门总成	VALVE ASS'Y	Y	1	
3	4120001795004	下阀门杆密封圈	SEALING WASHER	Y	1	
4	4120001795005	O形圈	O-RING	Y	1	





**K 车架**  
**FRAME**

山东临工工程机械有限公司  
**SHANDONG LINGONG CONSTRUCTION MACHINERY CO.,LTD.**

前车架总成 FRONT FRAME

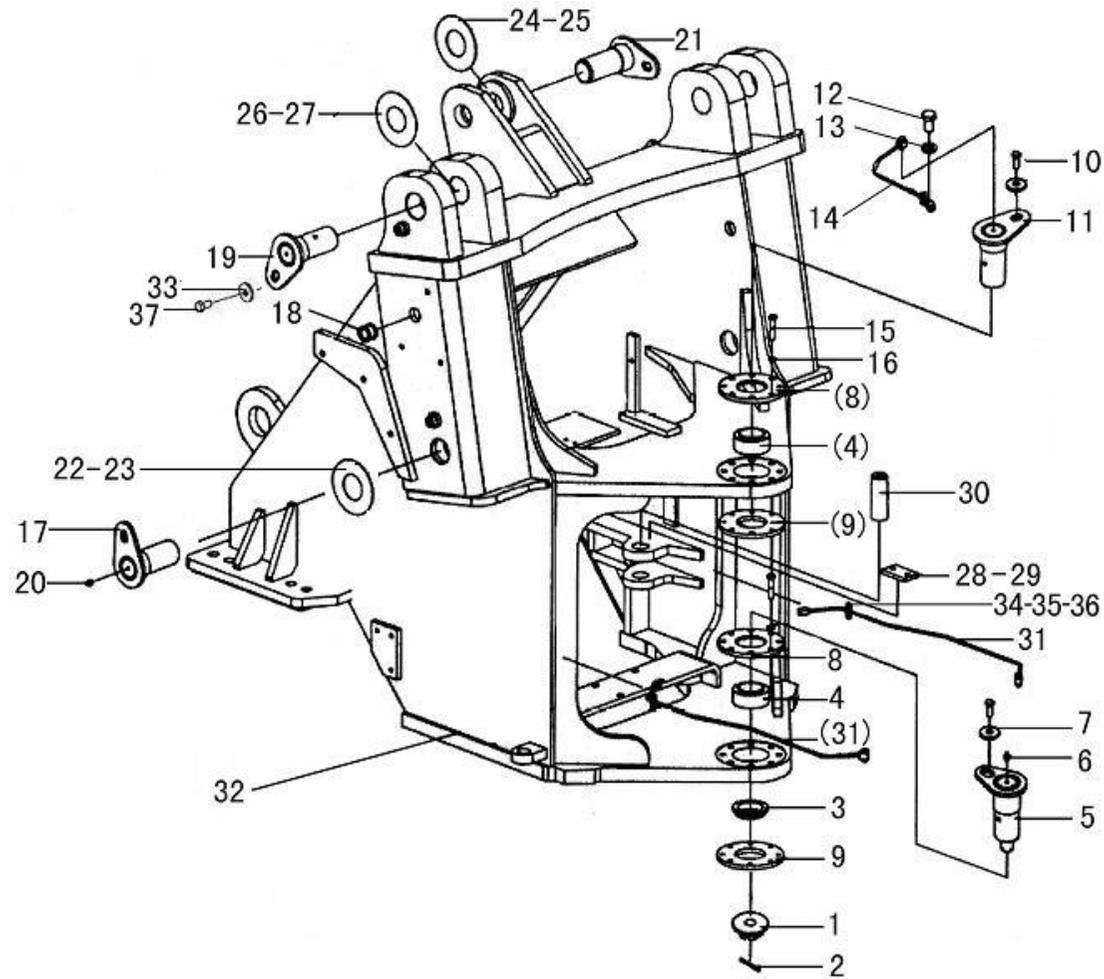

序号 Key	零件代号 Part No.	名称 Description	是否配件 Spare parts Y/N	数量 Qty	备注 Remarks
1	29250001061	开槽螺母	Y	1	
2	4016000113	开口销GB91-6.3*63EpZn-Q235A	N	1	
3	29250007591	套	Y	1	
4	4021000042	关节轴承GB9163-GE60ES-2RS	Y	2	
5	29250004031	下铰接销	Y	1	
6	29270008001	油管总成	Y	1	
7	4040000001	垫圈LGB001-12	Y	5	
8	29250004011	盘	Y	2	
9	29250004021	盘	Y	2	
10	4011000197	螺栓GB5783-M12*25EpZn-8.8	N	5	
11	29250004041	上铰接销	Y	1	
12	29250000291	通油螺栓	Y	3	
13	29250000301	垫片	Y	6	
14	29250004091	油管	Y	1	
15	4011000186	螺栓GB5782-M12*55EpZn-8.8	N	16	
16	4015000026	垫圈GB93-12-65Mn	N	16	
17	4043000424	销轴LGB301-60*133*250G-40Cr	Y	2	
18	29250001351	走线胶套	Y	4	
19	4043000425	销轴LGB301-85*133*260/2G-40Cr	Y	2	
20	4030000065	油杯JB7940.1-M10*1	Y	8	
21	4043000342	销轴LGB301-70*92*170G-40Cr	Y	1	
22	4043000141	垫片LGB303-60*120*2	Y	4	

前车架总成 FRONT FRAME

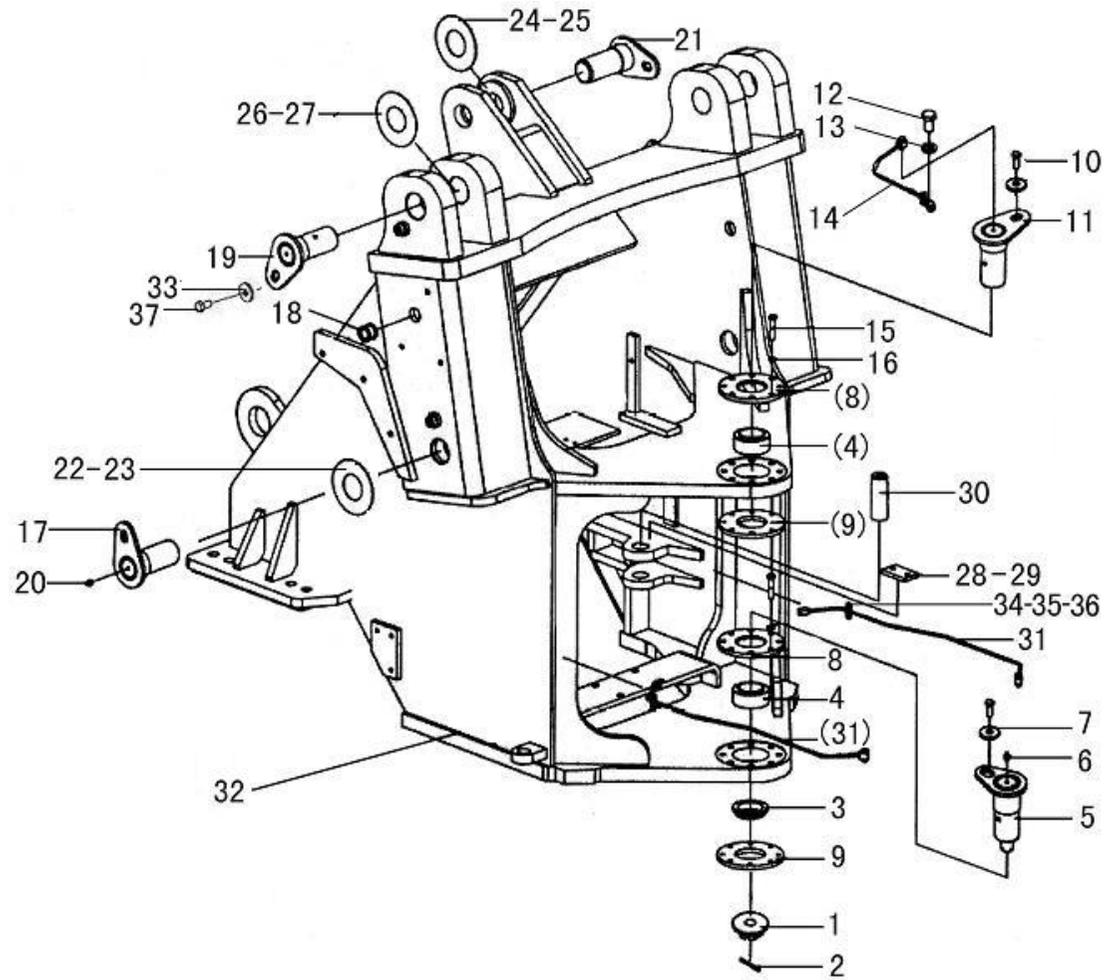

序号 Key	零件代号 Part No.	名称 Description	是否配件 Spare parts Y/N	数量 Qty	备注 Remarks	
23	4043000151	垫片LGB303-60*120*1	SPACER LGB303-60*120*1	Y	4	
24	4043000341	垫片LGB303-70*120*1	SPACER LGB303-70*120*1	Y	2	
25	4043000345	垫片LGB303-70*120*2	SPACER LGB303-70*120*2	Y	2	
26	4043000340	垫片LGB303-85*140*2	SHIM	Y	4	
27	4043000339	垫片LGB303-85*140*1	SHIM	Y	4	
28	29250001121	卡板	PLATE	Y	2	
29	29250001111	卡板	PLATE	Y	2	
30	29250004081	前转向销	FRONT PIN OF STEERING CYLINDER	Y	2	
31	29250008191	注油管	VITTA	N	2	
32	29240010271	前车架	FRONT FRAME	N	1	
33	4040000002	垫圈LGB001-16	WASHER LGB001-16	Y	2	
34	4014000024	螺钉GB818-M6*10EpZn-4.8	SCREW GB818-M6*10EpZn-4.8	N	6	
35	4015000035	垫圈GB93-6-65Mn	WASHER GB93-6-65Mn	N	6	
36	29250000311	管夹	CLIP	Y	3	
37	4011000093	螺栓GB5783-M16*25EpZn-8.8	BOLT GB5783-16*25EpZn-8.8	N	2	

灯架及挡泥瓦 LAMP FRAME AND FRONT FENDER

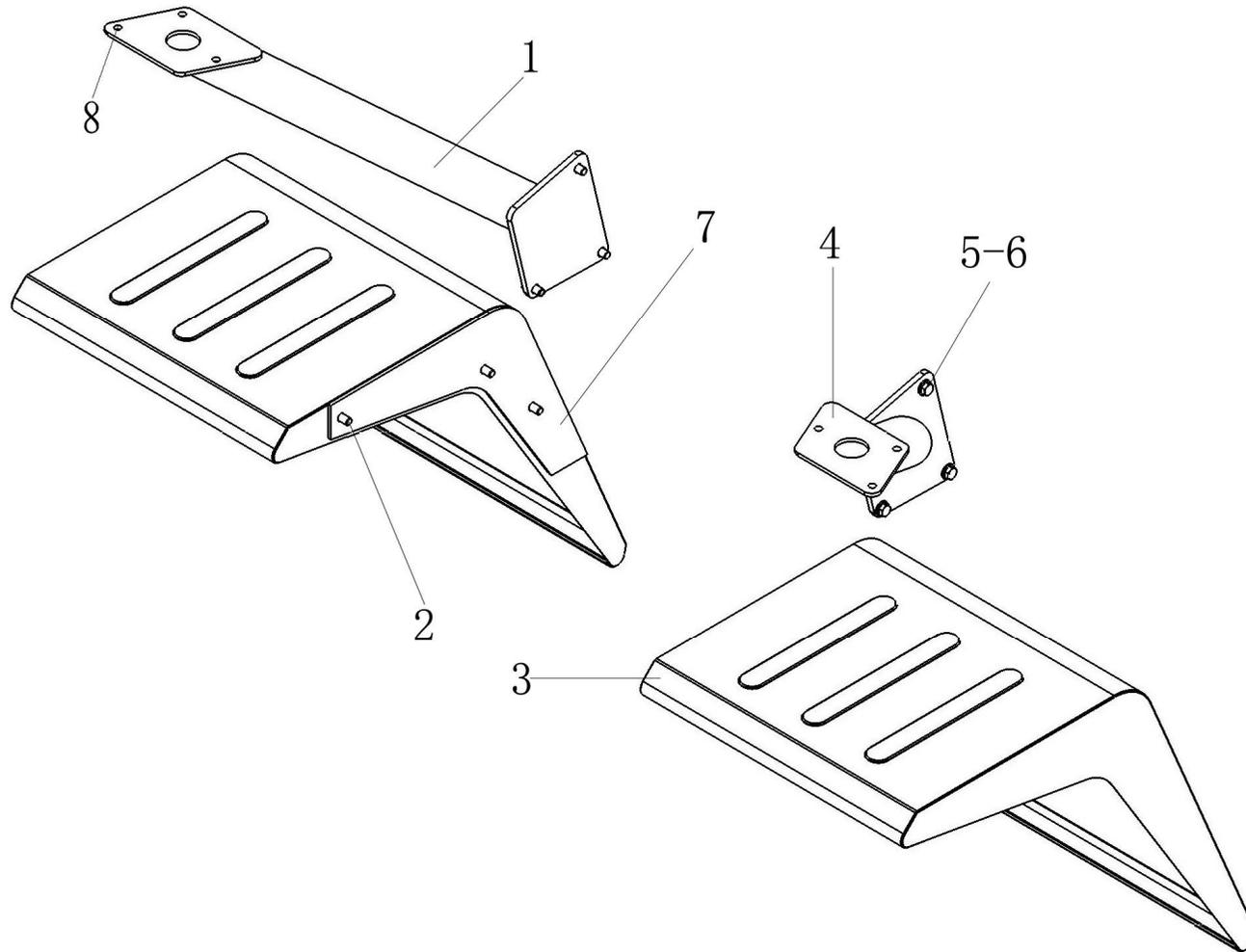

序号 Key	零件代号 Part No.	名称 Description	是否配件 Spare parts Y/N	数量 Qty	备注 Remarks
1	29340012271	右灯架	RIGHT BRACKET OF LAMP	Y	1
2	4011000560	螺栓GB16674-M12*25EpZn-8.8	BOLT GB16674-M12*25EpZn-8.8	N	6
3	29250001152	左前挡泥瓦	LEFT FRONT FENDER	Y	1
4	29340012251	左灯架	LEFT BRACKET OF LAMP	Y	1
5	4011000197	螺栓GB5783-M12*25EpZn-8.8	BOLT GB5783-M12*30EpZn-8.8	N	6
6	4015000168	垫圈GB97.1-12EpZn-300HV	WASHER GB97.1-12EpZn-300HV	N	6
7	29250001182	右前挡泥瓦	RIGHT FRONT FENDER	Y	1
8	4011000474	螺栓GB16674-M10*25EpZn-8.8	BOLT GB16674-M10*25EpZn-8.8	N	6



后车架及配件 REAR FRAME AND ACCESSORIES

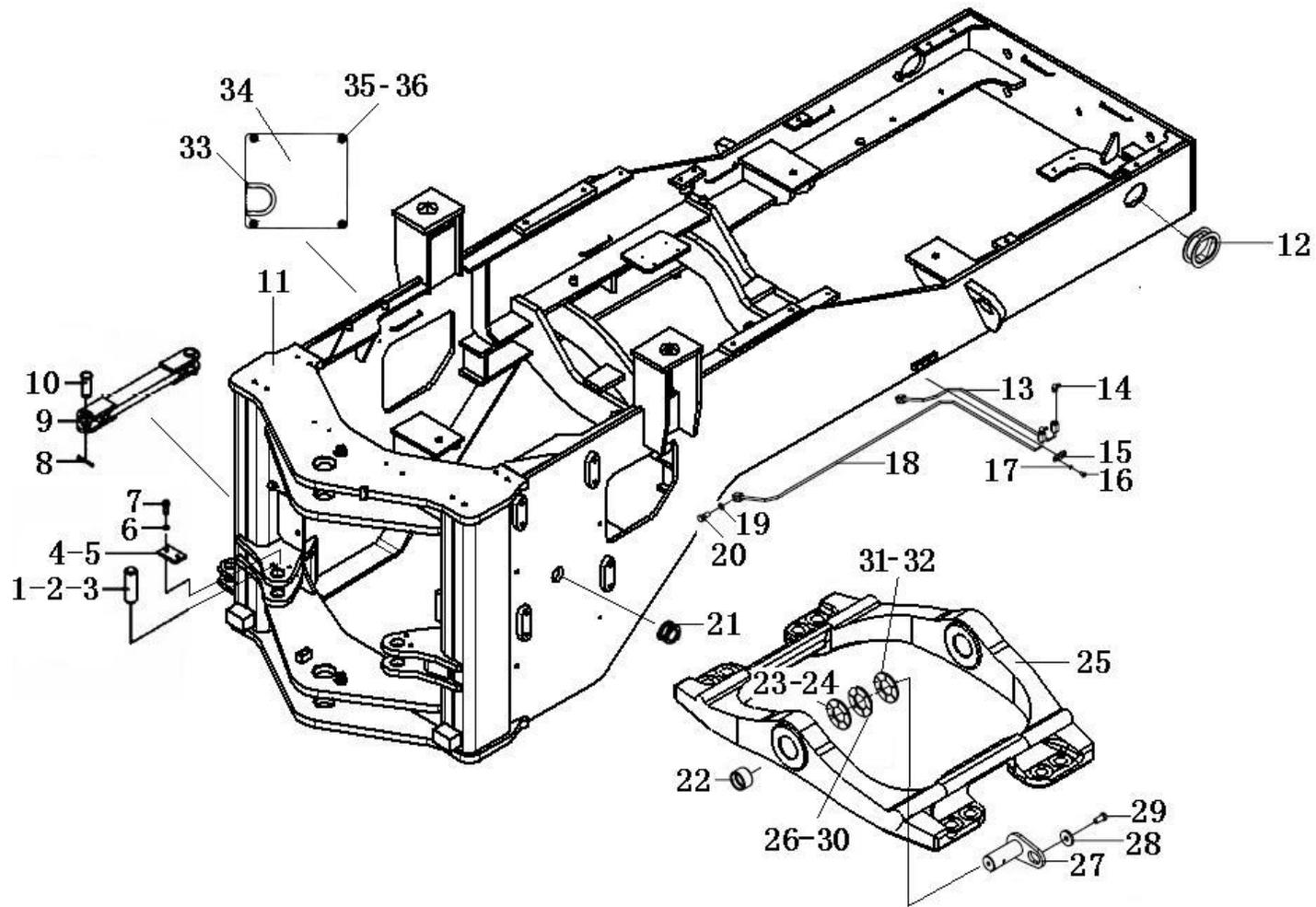

序号 Key	零件代号 Part No.	名称 Description	是否配件 Spare parts Y/N	数量 Qty	备注 Remarks
1	29270007971	后转向销	REAR PIN OF STEERING CYLINDER	Y	2
2	4043000064	垫片LGB303-40*70*1	SPACER LGB303-40*70*1	Y	4
3	4043000325	垫片LGB303-40*70*2	SPACER LGB303-40*70*2	Y	4
4	29250001111	卡板	PLATE	Y	2
5	29250001121	卡板	PLATE	Y	2
6	4011000197	螺栓GB5783-M12*25EpZn-8.8	BOLT GB5783-M12*30EpZn-8.8	N	4
7	4015000026	垫圈GB93-12-65Mn	WASHER GB93-12-65Mn	N	4
8	4016000040	开口销GB91-6.3*50EpZn-Q235A	SPLINT PIN GB91-6.3*50EpZn-Q235A	N	2
9	29270008891	锁定杆	MOUNT BAR	Y	1
10	4016000222	销轴GB882-B30*80EpZn-35	PIN GB882-B30*80EpZn-35	N	2
11	29260015371	后车架	REAR FRAME	Y	1
12	29270009101	走线胶套	RUBBER SLOEVE	Y	2
13	29270009261	副车架后油管	OSCILLATING FRAME BACK OIL PIPE	N	1
14	4030000065	油杯JB7940.1-M10*1	GREASE NIPPLE JB7940.1-M10*1	Y	4
15	29250000311	管夹	CLIP	Y	2
16	4014000024	螺钉GB818-M6*10EpZn-4.8	SCREW GB818-M6*10EpZn-4.8	N	4
17	4015000035	垫圈GB93-6-65Mn	WASHER GB93-6-65Mn	N	4
18	29270009241	副车架前油管	OSCILLATING FRAME FRONT OIL PIPE	N	1
19	29250000291	通油螺栓	BOLT	Y	2
20	29250000301	垫片	SPACER	Y	4
21	29270007551	走线胶套	RUBBER SLEEVE	Y	1
22	29270001031	套	BUSH	Y	2

后车架及配件 REAR FRAME AND ACCESSORIES

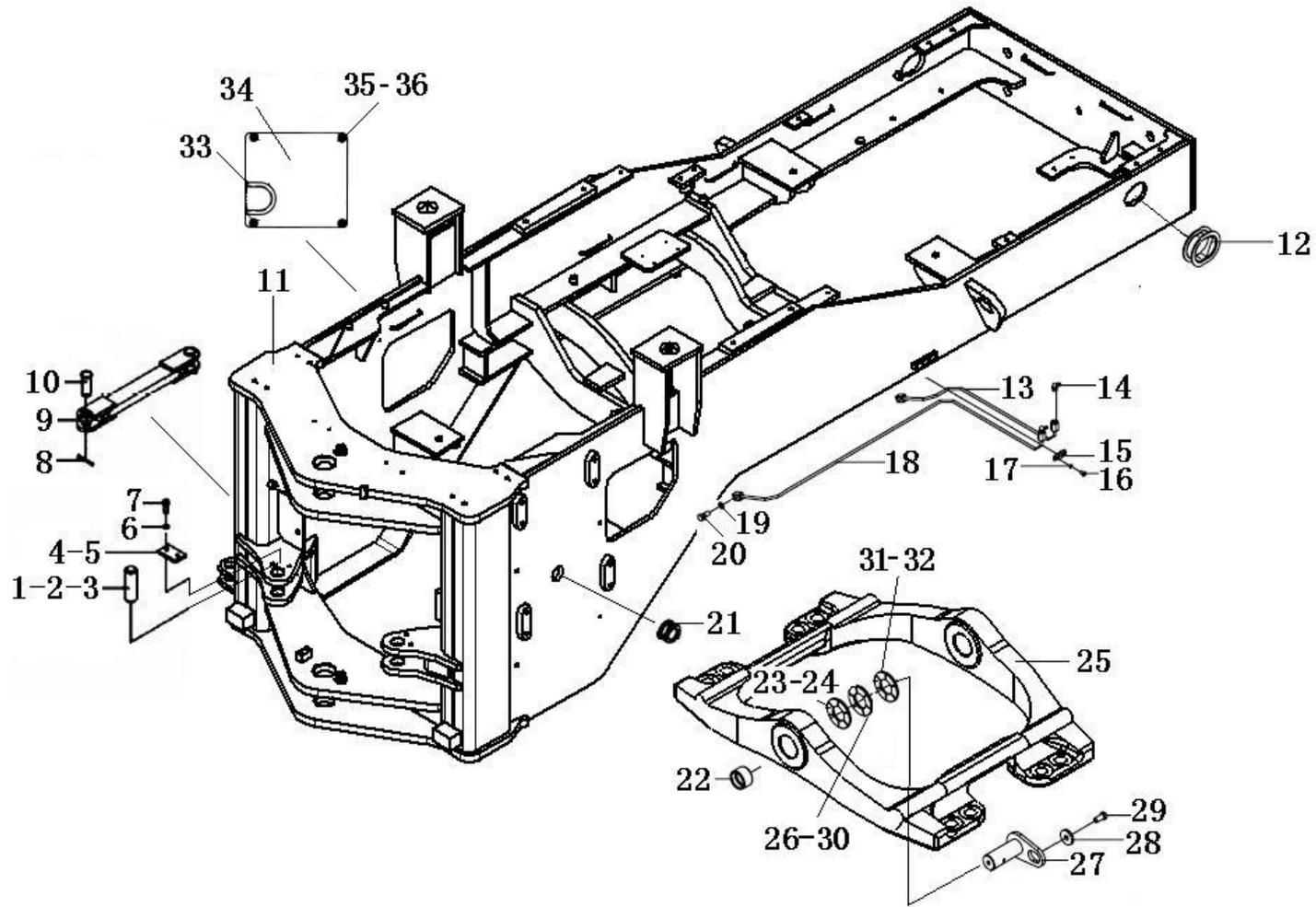

序号 Key	零件代号 Part No.	名称 Description	是否配件 Spare parts Y/N	数量 Qty	备注 Remarks	
23	29270001071	调整垫片	ADJUST SPACER	Y	2	
24	29270001051	调整垫片	ADJUST SPACER	Y	2	
25	29270001041	副车架	OSCILLATING FRAME	Y	1	
26	29270001061	调整垫片	ADJUST SPACER	Y	2	
27	2110900060	副车架销	PIN FOR OSCILLATING FRAME	Y	2	
28	4040000002	垫圈LGB001-16	WASHER LGB001-16	Y	2	
29	4011000093	螺栓GB5783-M16*25EpZn-8.8	BOLT GB5783-16*25EpZn-8.8	N	2	
30	29270009301	调整垫片	ADJUSTING SHIM	N	2	
31	29270009311	调整垫片	ADJUSTING SHIM	N	2	
32	29270009321	调整垫片	ADJUSTING SHIM	N	2	
33	29270007792	橡胶套	RUBBER BUSH	Y	2	
34	29270008551	盖板	HOOD	Y	2	
35	4011000102	螺栓GB5783-M8*16EpZn-8.8	BOLT GB5783-M8*16EpZn-8.8	N	8	
36	4015000256	垫圈GB96.1-8EpZn-300HV	WASHER GB96.1-8EpZn-300HV	N	8	

配重铁总成 COUNTER WEIGHT

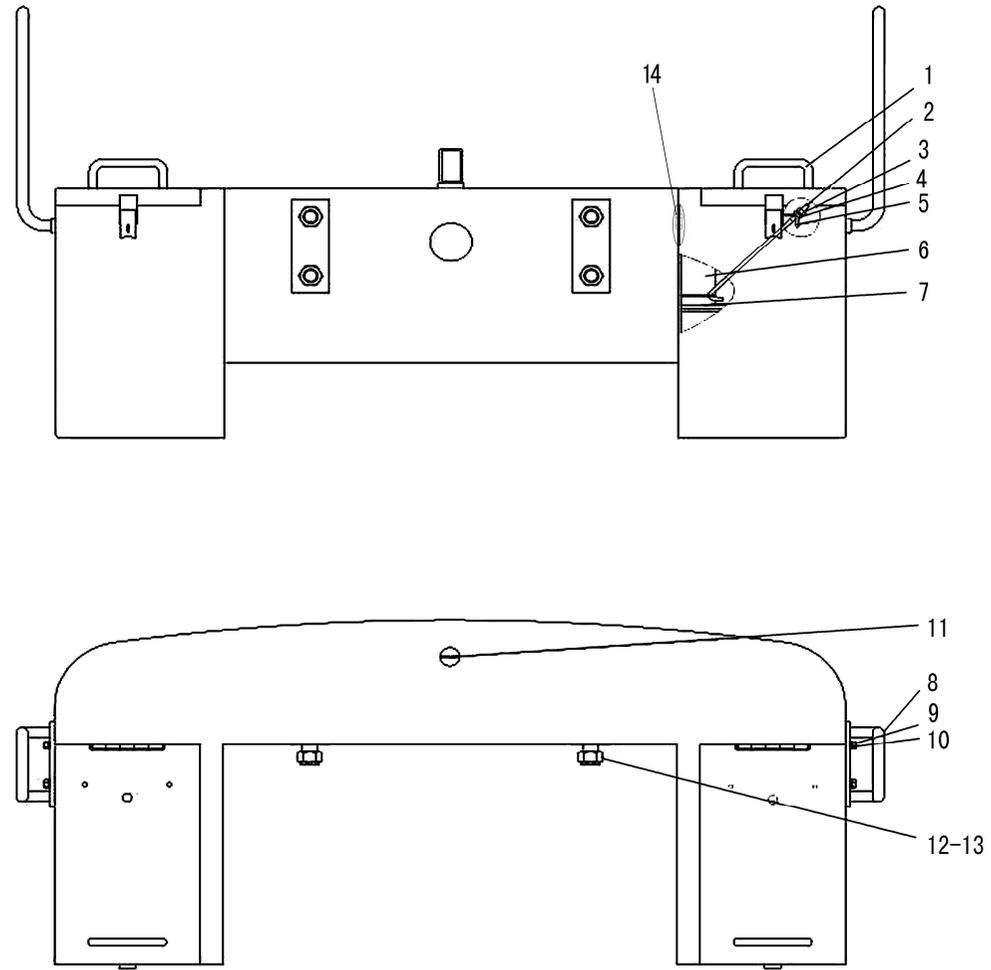

序号 Key	零件代号 Part No.	名称 Description	是否配件 Spare parts Y/N	数量 Qty	备注 Remarks	
1	29280008211	平衡铁	COUNTER WEIGHT	N	1	
2	29280000071	锁紧螺杆	BOLT OF MOUNT BAR	Y	4	
3	4013000033	螺母GB6170-M8EpZn-8	NUT GB6170-M8EpZn-8	N	4	
4	4015000072	垫圈GB97.1-8EpZn-300HV	WASHER GB97.1-8EpZn-300HV	N	4	
5	29280000081	锁紧角钢	MOUNT BAR	Y	2	
6	29280000051	侧胶板	MAT OF PASTERN	Y	4	
7	29280000061	下胶板	MAT OF PASTERN	Y	4	
8	29280007901	扶手	HANDRAIL	Y	2	
9	4011000089	螺栓GB5783-M12*30EpZn-8.8	BOLT GB5783-M12*30EpZn-8.8	N	4	
10	4015000168	垫圈GB97.1-12EpZn-300HV	WASHER GB97.1-12EpZn-300HV	N	4	
11	29280007541	牵引销	TRACTIVE PIN	Y	1	
12	4011000426	螺栓GB5785-M30*2*280EpZn-8.8	BOLT	N	4	
13	4013000064	螺母GB889.2-M30*2EpZn-8	LOCKING NUT GB889.2-M30*2-8	N	4	
14	29340011901	走线胶套	RUBBER SLEEVE	Y	2	



**L 驾驶室**  
**CAB GROUP**

山东临工工程机械有限公司  
**SHANDONG LINGONG CONSTRUCTION MACHINERY CO.,LTD.**

驾驶室总成 CAB ASSEMBLY

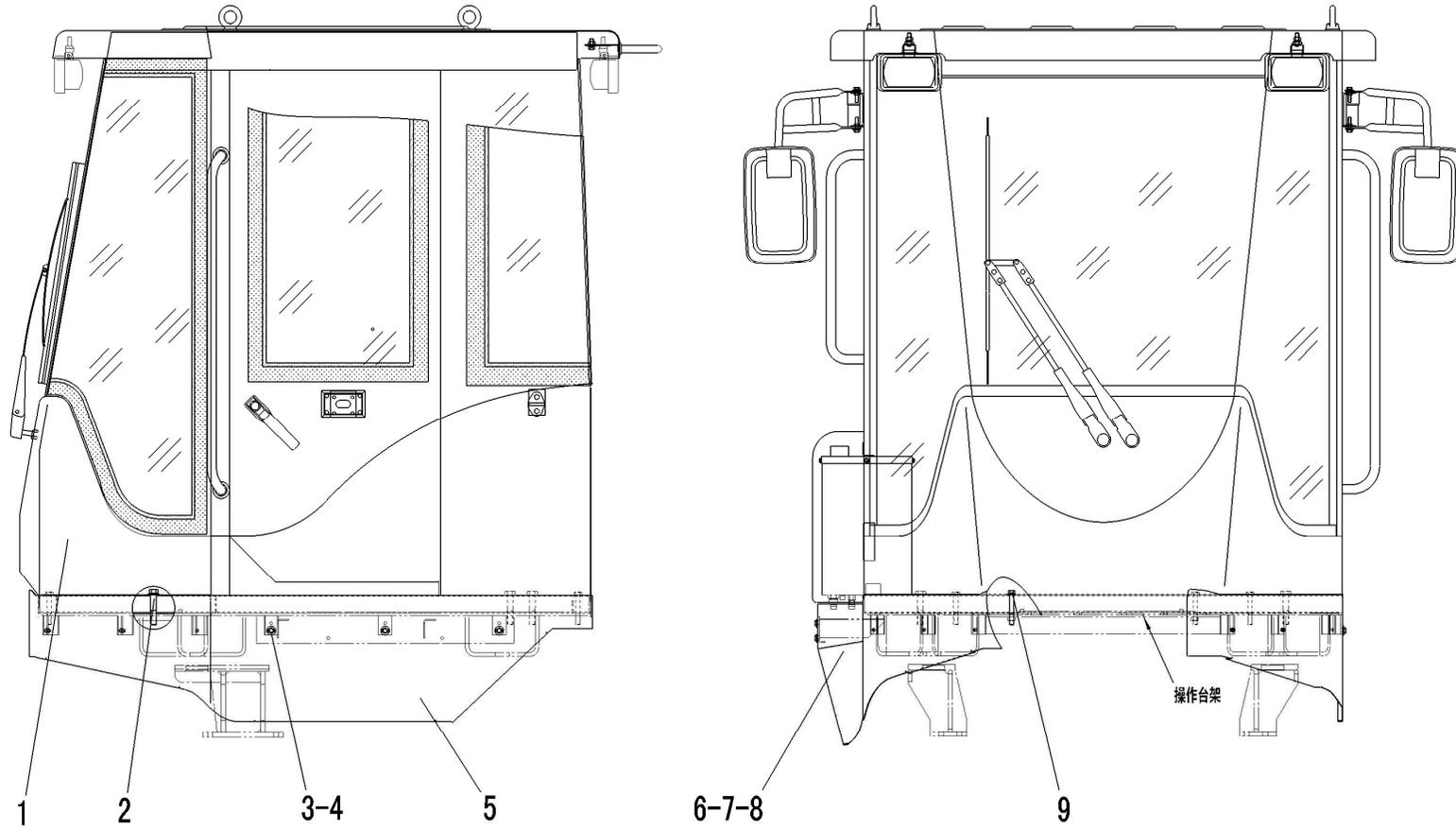

序号 Key	零件代号 Part No.	名称 Description	是否配件 Spare parts Y/N	数量 Qty	备注 Remarks	
1	29290008651	驾驶室 LG956	CAB LG956	Y	1	
2	4011000151	螺栓GB16674-M16*80EpZn-8.8	BOLT GB16674-M16*80EpZn-8.8	N	6	
3	4015000256	垫圈GB96.1-8EpZn-300HV	WASHER GB96.1-8EpZn-300HV	N	13	
4	4011000102	螺栓GB5783-M8*16EpZn-8.8	BOLT GB5783-M8*16EpZn-8.8	N	13	
5	29290009421	左护板	LEFT FENDER	Y	1	
6	29290009431	右后护板	RIGHT REAR FENDER	Y	1	
7	29290009441	右前护板	RIGHT FRONT FENDER	Y	1	
8	29290009451	卡子胶条	RUBBER	Y	1	
9	4011000144	螺栓GB16674-M12*80EpZn-8.8	BOLT GB16674-M12*80EpZn-8.8	N	4	



驾驶室 CAB GROUP

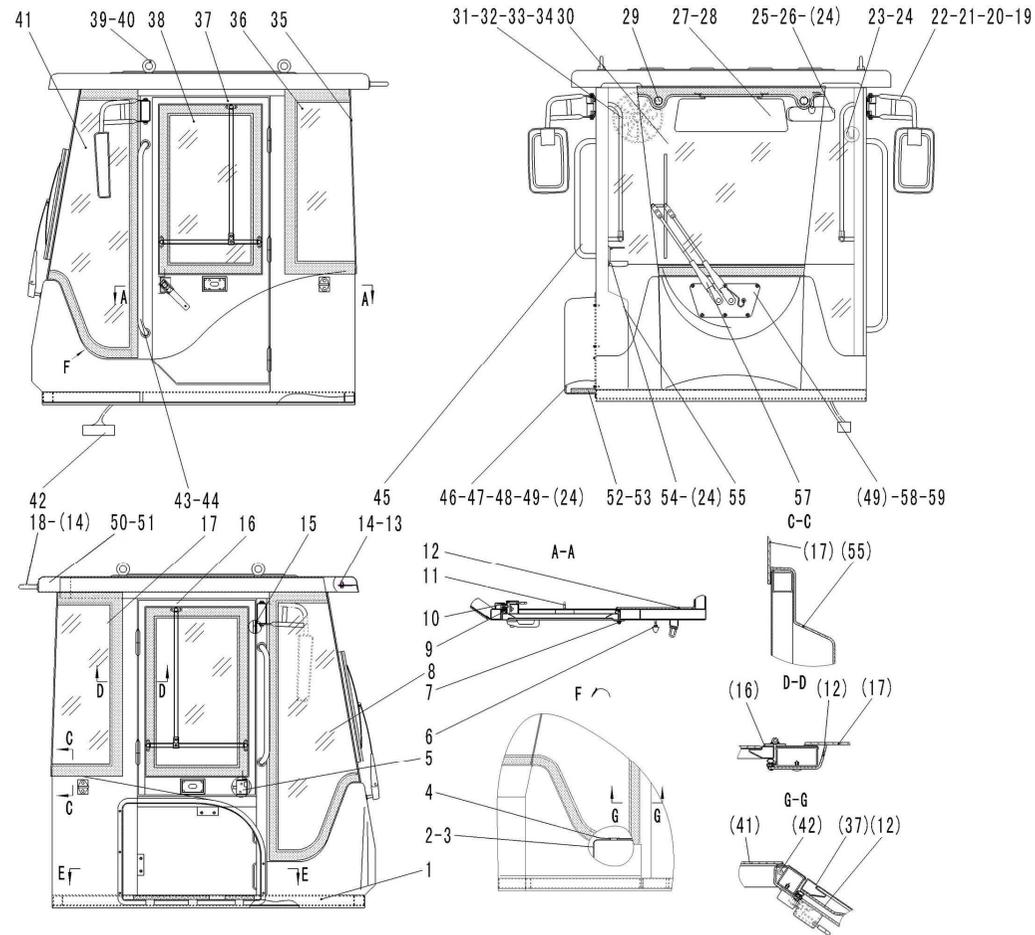

序号 Key	零件代号 Part No.	名称 Description	是否配件 Spare parts Y/N	数量 Qty	备注 Remarks	
1	4190000941	驾驶室框架LG956	CAB GROUP LG956	N	1	
2	4190000758	喷水壶 (24V)	BLOW CAN (24V)	Y	1	
3	29290009181	喷水壶盖	BLOW CAN CAP	N	1	
4	29290008871	左前侧下护板	LOWER COVER PLATE ON LEFT FRONT	Y	1	
5	4190000604	右开门锁	RIGHT LOCK	Y	1	
6	4190000596	上门缓冲碰头	CHECK OF UPPER GATE	Y	2	
7	4030000535	油杯JB7940.1-M6	OIL CUP JB7940.1-M6	N	5	
8	4190000945	右前玻璃	RIGHT FRONT GLASS	Y	1	
9	4190000966	车门胶条	RUBBER SPACER	Y	1	
10	4190000605	左开门锁	LEFT LOCK	Y	1	
11	4190000595	反锁NBS510	COUNTER LOCK NBS510	Y	2	
12	4190000942	基本内饰总成	BASIC TRIM GROUP	N	1	
13	4190000968	灯过渡板	TRANSTION PLATE OF LIGHT	N	4	
14	4011000474	螺栓GB16674-M10*25EpZn-8.8	BOLT GB16674-M10*25EpZn-8.8	N	6	
15	4190000967	车门胶条	RUBBER SPACER	Y	1	
16	4190000951	右门总成	RIGHT DOOR GUROUP	Y	1	
17	4190000948	右后玻璃	RIGHT REAR GLASS	Y	1	
18	4190000953	后扶手	REAR ARM REST	Y	1	
19	4015000072	垫圈GB97.1-8EpZn-300HV	WASHER GB97.1-8EpZn-300HV	N	4	
20	4015000036	垫圈GB93-8-65Mn	WASHER GB93-8-65Mn	N	4	
21	4011000105	螺栓GB5783-M8*20EpZn-8.8	BOLT GB5783-M8*20EpZn-8.8	N	4	
22	4190000575	倒车镜总成	BACK UP GLASS GROUP	Y	2	

驾驶室 CAB GROUP

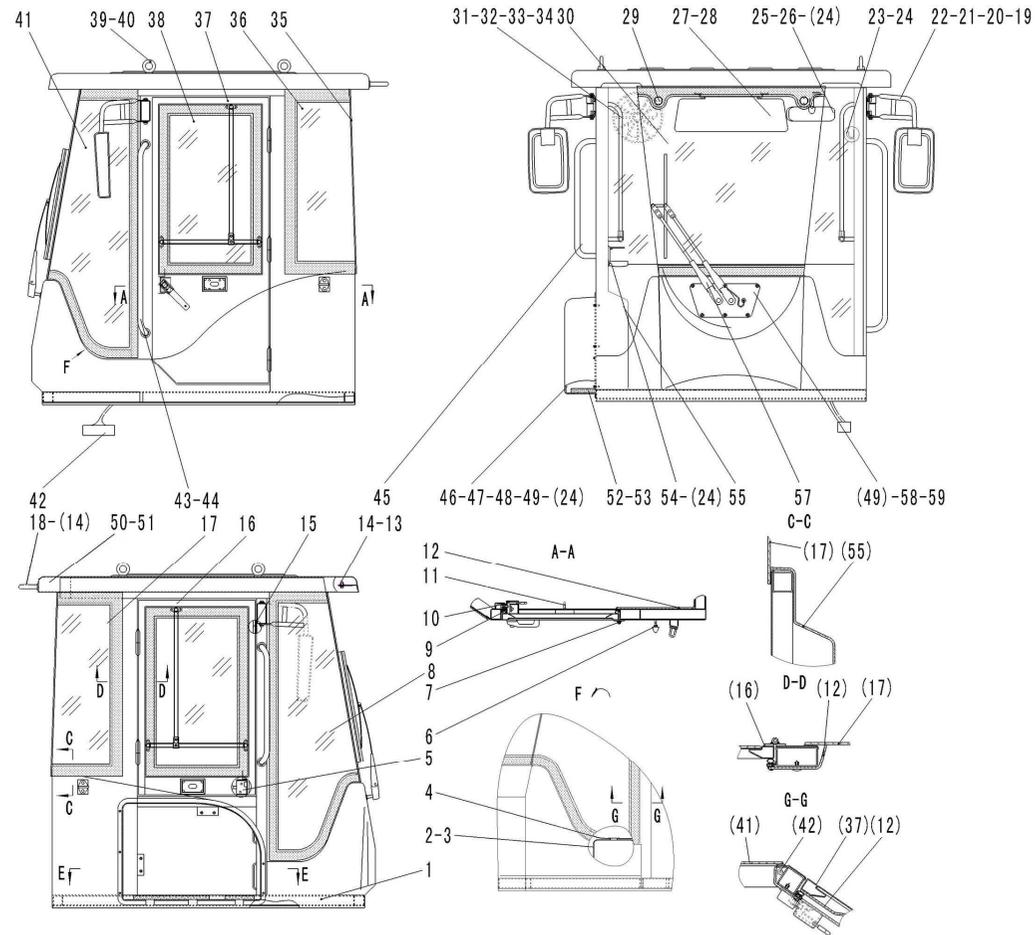

序号 Key	零件代号 Part No.	名称 Description	是否配件 Spare parts Y/N	数量 Qty	备注 Remarks	
23	4190000581	挂衣钩	CLOTHING HOOK	N	1	
24	4014000037	自攻螺钉GB845-ST4.2*19-C-H	SCREW GB845-ST4.2*19-C-H	N	17	
25	4190000577	室内后视镜	BACK MIRROR IN HOUSE	Y	1	
26	4014000046	螺钉GB818-M5*30EpZn-4.8	SCREW GB818-M5*30EpZn-4.8	N	1	
27	4014000077	螺钉GB819-M6*16EpZn-4.8	SCREW GB819-M6*16EpZn-4.8	N	2	
28	4190000585	遮阳板	SHADOW SHIELD	Y	1	
29	4190000952	玻璃吊点固定总成	GLASS SUSPENSION CENTER FIXED GROUP	Y	4	
30	4190000943	前挡风玻璃	FRONT WINDSHIELD	Y	1	
31	4190000608	电风扇	ELECTRIC FAN	Y	1	
32	4014000063	螺钉GB818-M6*25EpZn-4.8	SCREW GB818-M6*25EpZn-4.8	N	3	
33	4015000207	垫圈GB97.1-6EpZn-300HV	WASHER GB97.1-6EpZn-300HV	N	3	
34	4015000035	垫圈GB93-6-65Mn	WASHER GB93-6-65Mn	N	3	
35	4190000949	后玻璃	REAR GLASS	Y	1	
36	4190000947	左后玻璃	LEFT REAR GLASS	Y	1	
37	4190000950	左门总成	LEFT DOOR GROUP	Y	1	
38	4190000946	门玻璃	DOOR GLASS	Y	2	
39	4014000028	螺钉GB825-M16EpZn-25	SCREW GB825-M16EpZn-25	N	4	
40	4190000956	密封垫圈	SEAL WASHER	N	4	
41	4190000944	左前玻璃	LEFT FRONT GLASS	Y	1	
42	4190000920	LG956驾驶室布线	LG956 CAB WIRING	N	1	
43	4190000965	左扶手	LEFT ARM REST	Y	1	
44	4014000055	螺钉GB70.1-M12*30EpZn-8.8	SCREW GB70.1-M12*30EpZn-8.8	N	4	

驾驶室 CAB GROUP

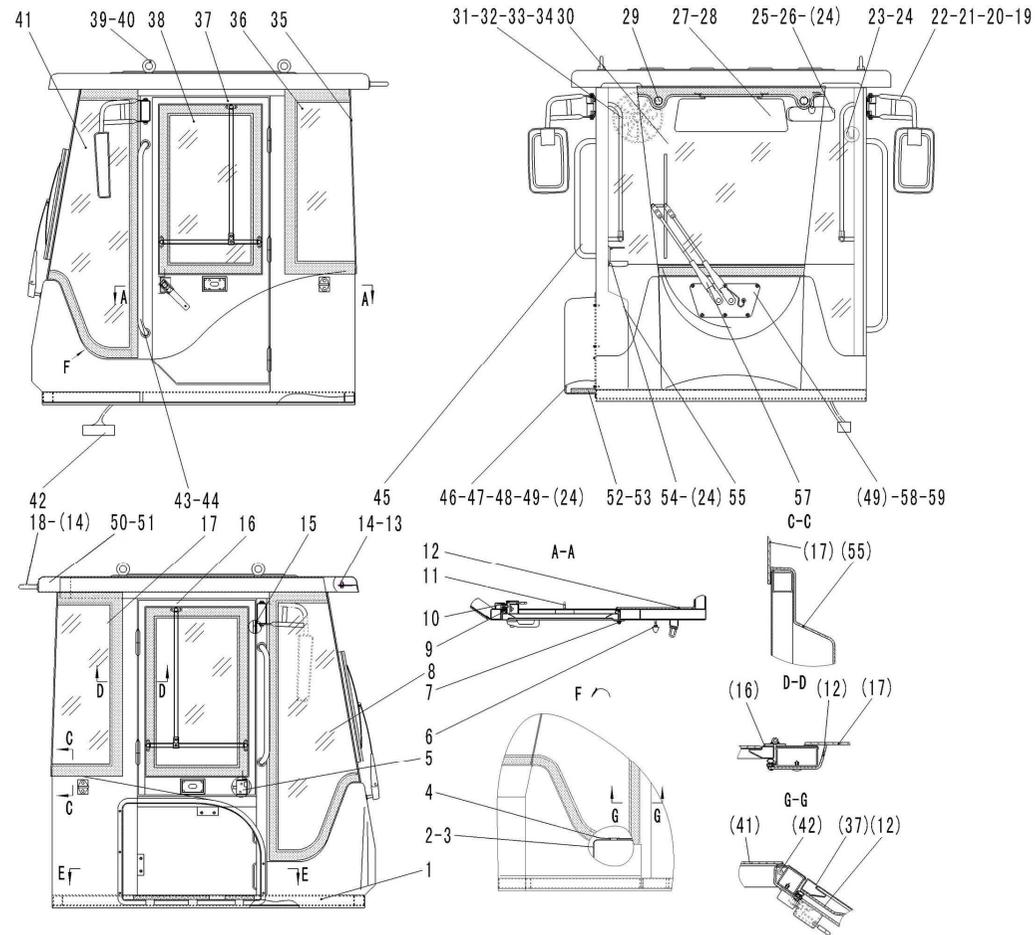

序号 Key	零件代号 Part No.	名称 Description	是否配件 Spare parts Y/N	数量 Qty	备注 Remarks	
45	4190000957	右扶手	RIGHT ARM REST	Y	1	
46	29290009141	蒸发器外护罩	BOILER'S HOOD	N	1	
47	29290009151	进气格栅	AIR-INLET GRILLE	Y	1	
48	29290009171	空滤海绵	SPONGE	N	1	
49	4011000680	螺栓GB16674-M6*30EpZn-8.8	BOLT GB16674-M6*30EpZn-8.8	N	11	
50	4190000958	橡胶塞-30	RUBBER COVR-30	N	1	
51	4190000959	橡胶塞-10	RUBBER COVR-10	N	2	
52	4190000960	管密封海绵	SEAL OF TUBE SPONGE	N	1	
53	4190000961	线密封海绵	LINEAR SEALING SPONGE	N	1	
54	4190000962	水杯座	CUP SEAT	Y	1	
55	29290008981	蒸发器内护罩	SHELL	N	1	
56	4190000578	顶灯	DOME LAMP	Y	1	
57	4190000599	雨刮器	WIPER BUTTON	Y	1	
58	4190000963	雨刮器盖板	WIPER BUTTON CAP	Y	1	
59	4190000964	雨刮器密封圈	WIPER BUTTON GASKET	Y	1	

操作台架 BENCH GROUP

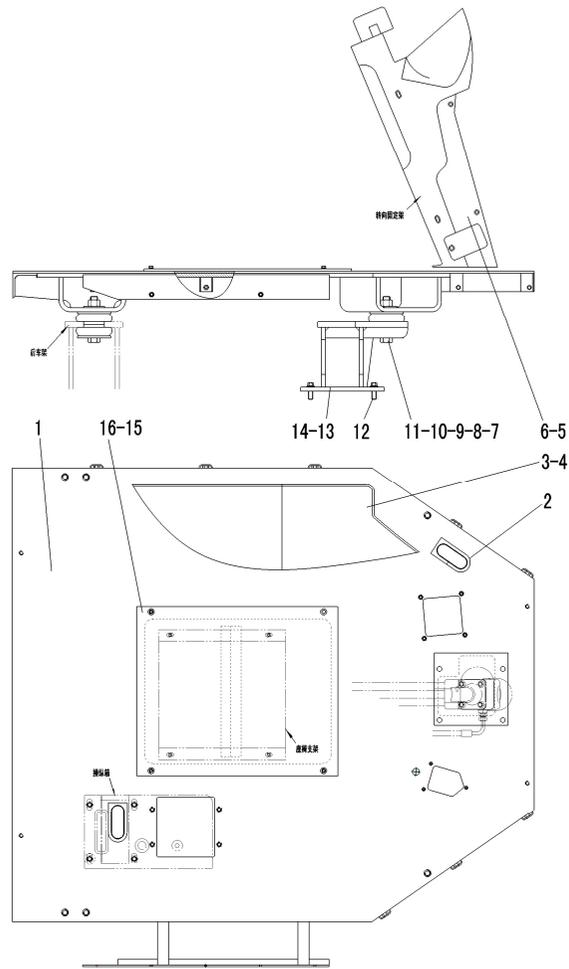

序号 Key	零件代号 Part No.	名称 Description	是否配件 Spare parts Y/N	数量 Qty	备注 Remarks	
1	29310013411	台架-LG936	BENCH LG936	Y	1	
2	29310011661	走线胶套	RUBBER SLOEVE	Y	2	
3	29310011761	后地板垫皮	BACK FLOOR CUSHION	Y	1	
4	29310011631	前地板垫皮	FRONT FLOOR CUSHION	Y	1	
5	4190000872	方向机罩	DIRECTION HOOD	Y	1	
6	29310011421	密封垫	SEALING PLATE	Y	1	
7	4011000648	螺栓GB5782-M20*120EpZn-8.8	BOLT GB5782-M20*120EpZn-8.8	N	4	
8	4013000132	螺母GB889.1-M20EpZn-8	NUT GB889.1-M20EpZn-8	N	4	
9	4015000176	垫圈GB97.1-20EpZn-300HV	WASHER GB97.1-20EpZn-300HV	N	4	
10	4110000459	减震器CBB95-1	SHOCK ABSORBER CBB95-1	Y	8	
11	29050000121	垫圈	WASHER	Y	8	
12	4011000477	螺栓GB16674-M12*35EpZn-8.8	BOLT GB16674-M12*35EpZn-8.8	N	8	
13	29310013271	左前支承座	LEFT FRONT FULCRUM BEARING	Y	1	
14	29310013281	右前支承座	RIGHT FRONT FULCRUM BEARING	Y	1	
15	29310011591	维修盖	REPAIR COVER	Y	1	
16	4011000455	螺栓GB16674-M8*25EpZn-8.8	BOLT GB16674-M8*25EpZn-8.8	N	6	

座椅总成(321013) SEAT ASSEMBLY

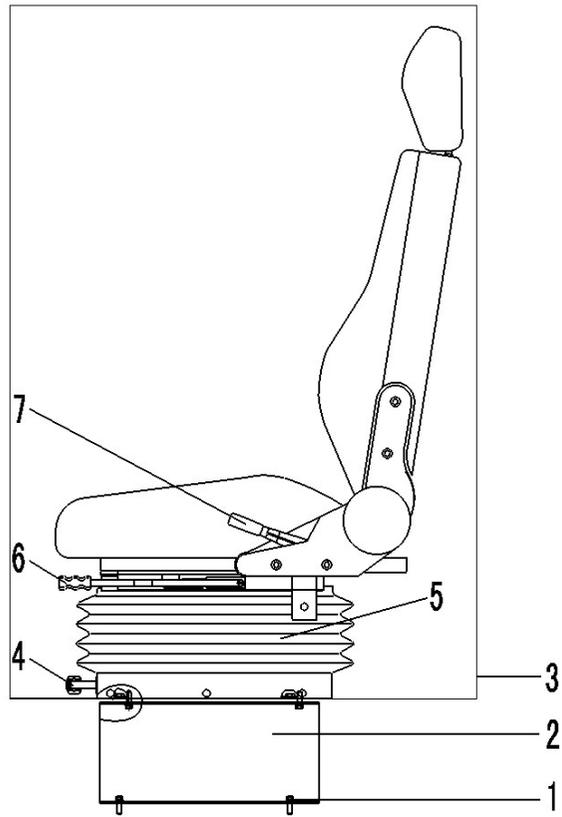

序号 Key	零件代号 Part No.	名称 Description	是否配件 Spare parts Y/N	数量 Qty	备注 Remarks	
1	4011000106	螺栓GB5783-M8*25EpZn-8.8	BOLT GB5783-M8*25EpZn-8.8	N	8	
2	29300007561	座椅支架	SEAT BEARER	Y	1	
3	4190000924	座椅LG01	SEAT -LG01	Y	1	
4	4190000927002	体重调节手柄XFZY-1-1.0-4	WEIGHT REGULATING HANDLE	Y	1	
5	4190000927003	下底座XFZY-1-1.0	DASHPOT ASSEMBLY	Y	1	
6	4190000927004	滑轨部件XFZY-2-02	SLIDE RAIL (INCLUDE REGULATING HANDLE)	Y	1	
7	4190000927005	调角器部件XFZY-2-00-1/2	ADJUSTER PARTS	Y	1	



操纵箱总成 OPERATE BOX

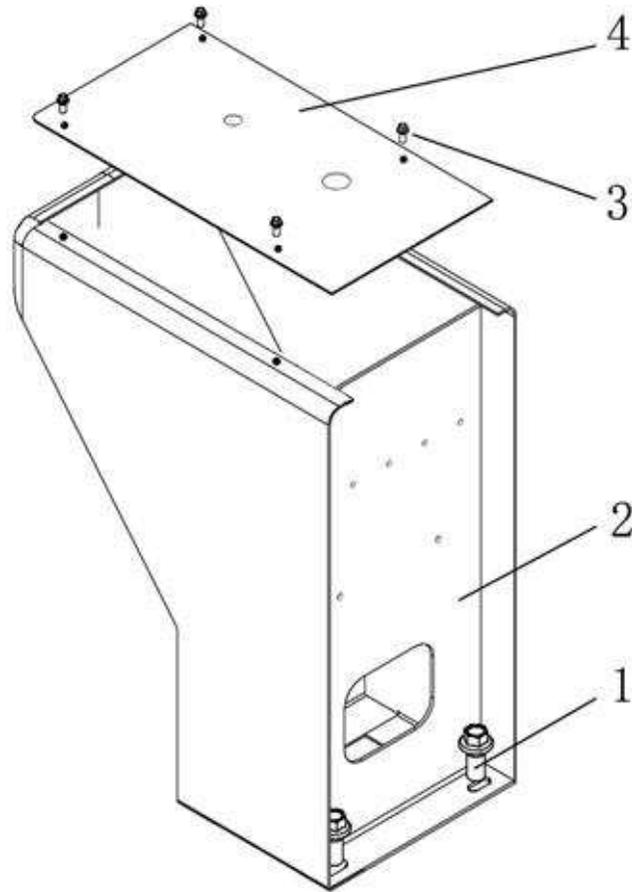

序号	零件代号		名称	是否配件	数量	备注
Key	Part No.		Description	Spare parts Y/N	Qty	Remarks
1	4011000560	螺栓GB16674-M12*25EpZn-8.8	BOLT GB16674-M12*25EpZn-8.8	N	4	
2	29320009092	操纵箱体	OPERATE BOX	Y	1	
3	4014000058	螺钉GB70.1-M6*20EpZn-8.8	SCREW GB70.1-M6*20EpZn-8.8	N	4	
4	29320009151	操纵箱盖	COVER	Y	1	



座椅总成(331002) SEAT ASSEMBLY

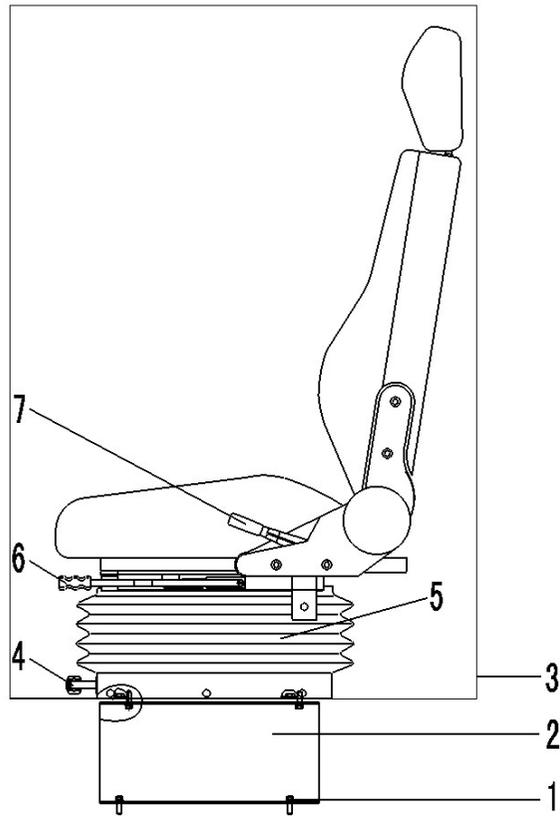

序号 Key	零件代号 Part No.	名称 Description	是否配件 Spare parts Y/N	数量 Qty	备注 Remarks
1	4011000106	螺栓GB5783-M8*25EpZn-8.8	N	8	
2	29300007561	座椅支架	Y	1	
3	4190000924	座椅LG01	Y	1	
4	4190000927102	调荷手柄SCJZ-0002	Y	1	
5	4190000927104	减震器总成SCJZ-7	Y	1	
6	4190000927103	滑道总成HD24-0000	Y	1	
7	4190000927105	丰田调角器总成(左)TJ1-0000	Y	1	





**M 覆盖件系统**  
**CONVER SYSTEM**

山东临工工程机械有限公司  
**SHANDONG LINGONG CONSTRUCTION MACHINERY CO.,LTD.**

发动机罩总成 ENGINE HOOD ASSEMBLY

序号 Key	零件代号 Part No.	名称 Description	是否配件 Spare parts Y/N	数量 Qty	备注 Remarks
1	29330024591	发动机罩	EMPTY	Y	1
2	29330024531	左侧门	EMPTY	Y	1
3	29330024561	右侧门	EMPTY	Y	1
4	29330024841	窗棂	EMPTY	Y	1
5	29330011191	左上扶手	LEFT UPPER HANDRALL	Y	1
6	29330011241	右上扶手	RIGHT UPPER HANDRALL	Y	1
7	29330011391	气弹簧	AIR SPRING	Y	4
8	29340009091	拉杆	LINK ASSEM	Y	1
9	4190000916	门锁NBS5013A	LOCK NBS5013A	Y	1
10	4030000749	卡子胶条GB7526-940-胶条	CHIP BAR GB7526-940-胶条	Y	2

左台架总成 LEFT BENCH GROUP

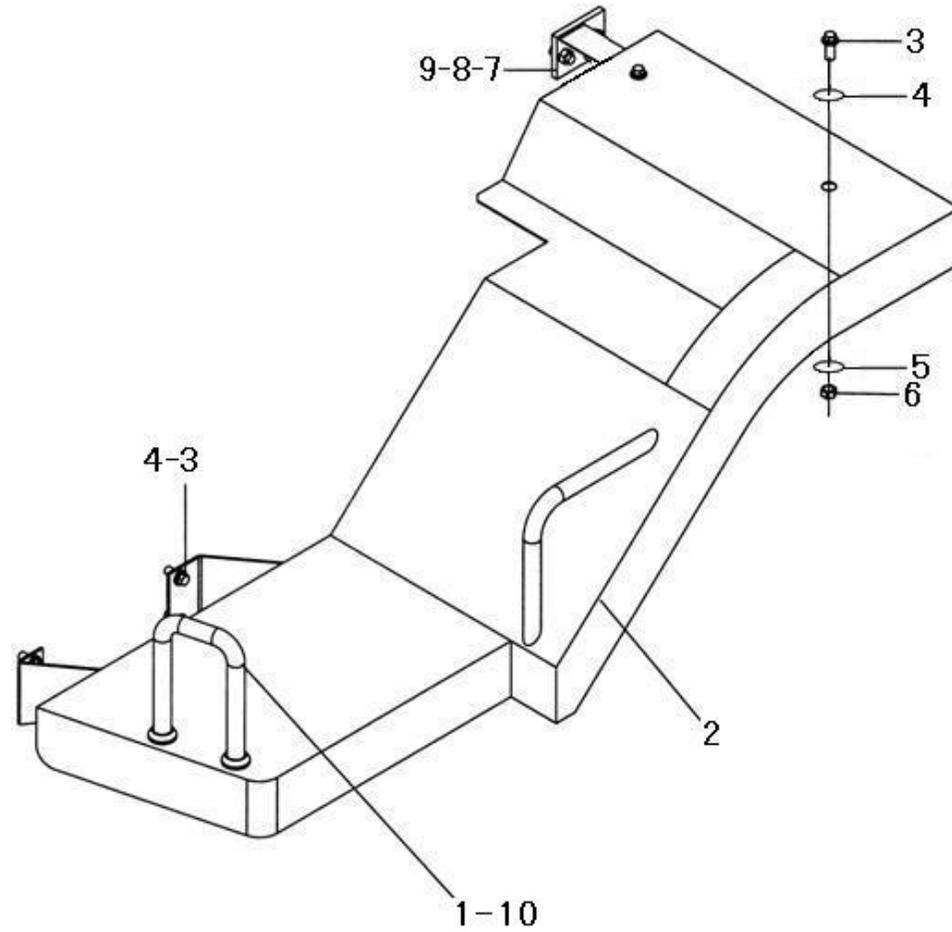

序号 Key	零件代号 Part No.	名称 Description	是否配件 Spare parts Y/N	数量 Qty	备注 Remarks
1	29340012142	前扶手	Y	1	
2	29340017841	左台架	Y	1	
3	4011000197	螺栓GB5783-M12*25EpZn-8.8	N	6	
4	4015000186	垫圈GB96.1-12EpZn-300HV	N	6	
5	4015000168	垫圈GB97.1-12EpZn-300HV	N	2	
6	4013000011	螺母GB6170-M12EpZn-8	N	2	
7	29340012161	左支撑架	Y	1	
8	4011000089	螺栓GB5783-M12*30EpZn-8.8	N	2	
9	29330023151	垫圈12	Y	2	
10	4011000560	螺栓GB16674-M12*25EpZn-8.8	N	2	

右台架总成 RIGHT BENCH GROUP

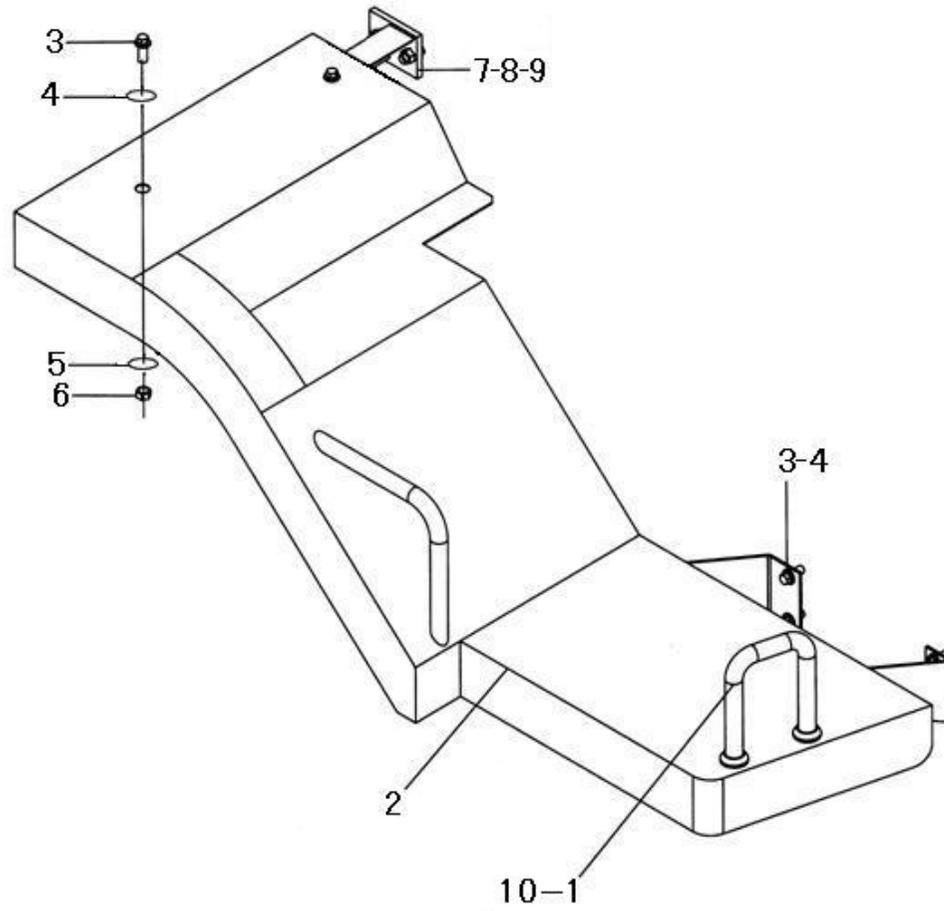

序号 Key	零件代号 Part No.	名称 Description	是否配件 Spare parts Y/N	数量 Qty	备注 Remarks
1	29340012142	前扶手	Y	1	
2	29340017911	右台架	Y	1	
3	4011000197	螺栓GB5783-M12*25EpZn-8.8	N	6	
4	4015000186	垫圈GB96.1-12EpZn-300HV	N	6	
5	4015000168	垫圈GB97.1-12EpZn-300HV	N	2	
6	4013000011	螺母GB6170-M12EpZn-8	N	2	
7	2120900056	右支承架	Y	1	
8	4011000089	螺栓GB5783-M12*30EpZn-8.8	N	2	
9	29330023151	垫圈12	Y	2	
10	4011000560	螺栓GB16674-M12*25EpZn-8.8	N	2	

后转向灯罩 REAR STEERING LAMP HOOD

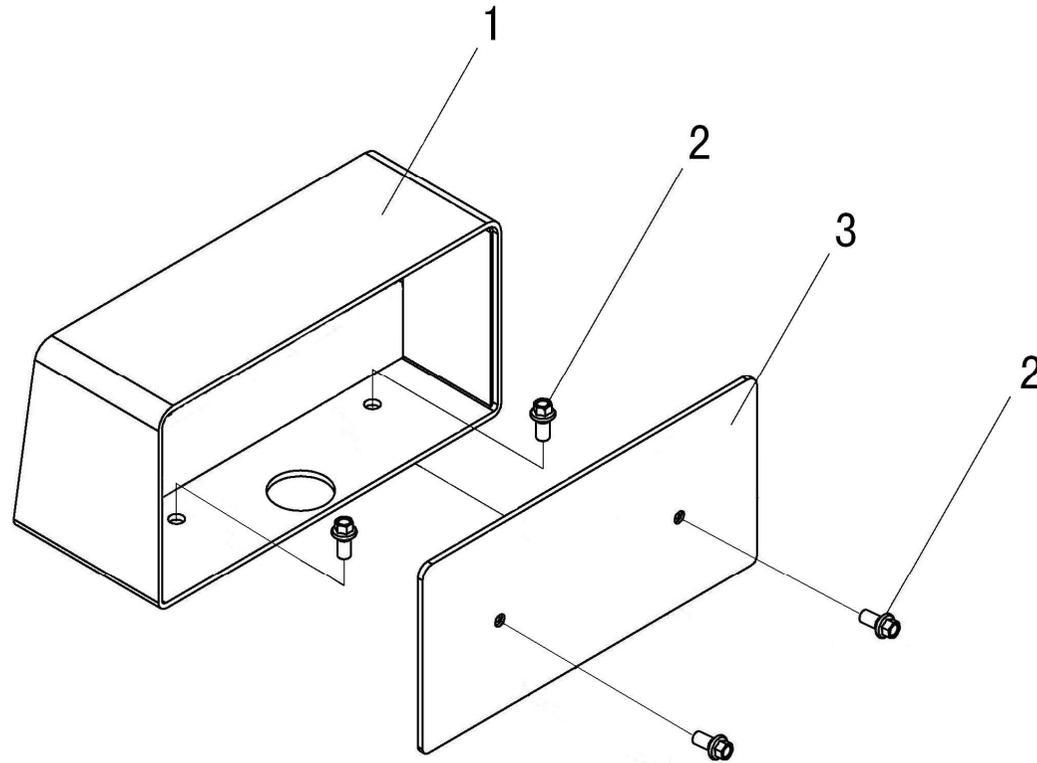

序号 Key	零件代号 Part No.	名称 Description	是否配件 Spare parts Y/N	数量 Qty	备注 Remarks	
1	29340002431	灯架	LAMP FRAME	Y	1	
2	4011000461	螺栓GB16674-M8*16EpZn-8.8	BOLT GB16674-M8*16EpZn-8.8	N	4	
3	29340002442	后板	REAR PLATE	Y	1	





**标志与标识 SIGN AND LOGO**

序号 Key	零件代号 Part No.	名称 Description	是否配件 Spare parts Y/N	数量 Qty	备注 Remarks	
1	29360010061	中国名牌标志	CHINA FAMOUS BRAND LOGO	N	1	
2	29360009511	润滑示意图	LUBRICATION DIAGRAM	N	1	
3	4044000016	启动开关警示标志LGB401-D04	MARK-STARTING SWITCH-LGB401-D04	N	1	
4	29360011711	SDLG-750	SDLG-750	N	2	
5	29360008741	提升臂位置安全标志	ARM POSITION TO ENHANCE SAFETY SIGNS	N	2	
6	29360010171	动臂危险标志	DANGEROUS SIGNS BOOM	N	2	
7	4019000012	铆钉GB827-3*5-BL2	RIVET GB827-3*5-BL2	N	4	
8	29360012391	4613114A29铭牌	NAMEPLATE	N	1	
9	29360010571	挡风窗喷水器标识	WATER JET WIND WINDOW	N	1	
10	29360008781	铰接转向图形标志	GRAPHIC SIGNS ARTICULATED STEERING	N	2	
11	4044000079	单手柄操作标志(中文)	SINGLE-HANDLE OPERATION OF SIGNS (IN CHINESE)	N	1	
12	29360012551	储气罐注意放水标识(中文)	SIGN	Y	1	
13	4044000010	驾驶室门注意标志LGB401-C01	MARK-LGB401-C01	N	1	
14	4044000021	防冻液标志LGB401-F04	MARK-ANTIFREEZE-LGB401-F04	N	2	
15	29360009171	液压油箱标志	HYDRAULIC TANK LOGO	N	1	
16	28310002241	高温警告标志	HIGH TEMPERATURE WARNING SIGNS	N	1	
17	26360000121	高温油和水的注意标志	SAFETY LOGO	N	1	
18	4044000018	起吊标志LGB401-F01	MARK-SLINGING-LGB401-F01	N	4	
19	4044000015	接触机器警示标志LGB401-D03	MARK-LGB401-D03	N	2	
20	4044000014	安全距离警示标志LGB401-D02	SAFETY DISTANCE SIGNS	N	2	
21	29360012381	LG946L机型标识	SIGN	Y	2	
22	29360009201	燃油箱标志	FUEL TANK MARKING	N	1	



**标志与标识 SIGN AND LOGO**

序号 Key	零件代号 Part No.	名称 Description	是否配件 Spare parts Y/N	数量 Qty	备注 Remarks
23	29360011741	SDLG-450	N	1	
24	29360011791	山东临工字体	N	1	
25	29360010941	山东临工图形文字标志	N	2	
26	29360010751	操作注意标志	N	1	
27	29360010761	行驶注意标志	N	1	



下梯总成 DOWN LADDER ASSEMBLY

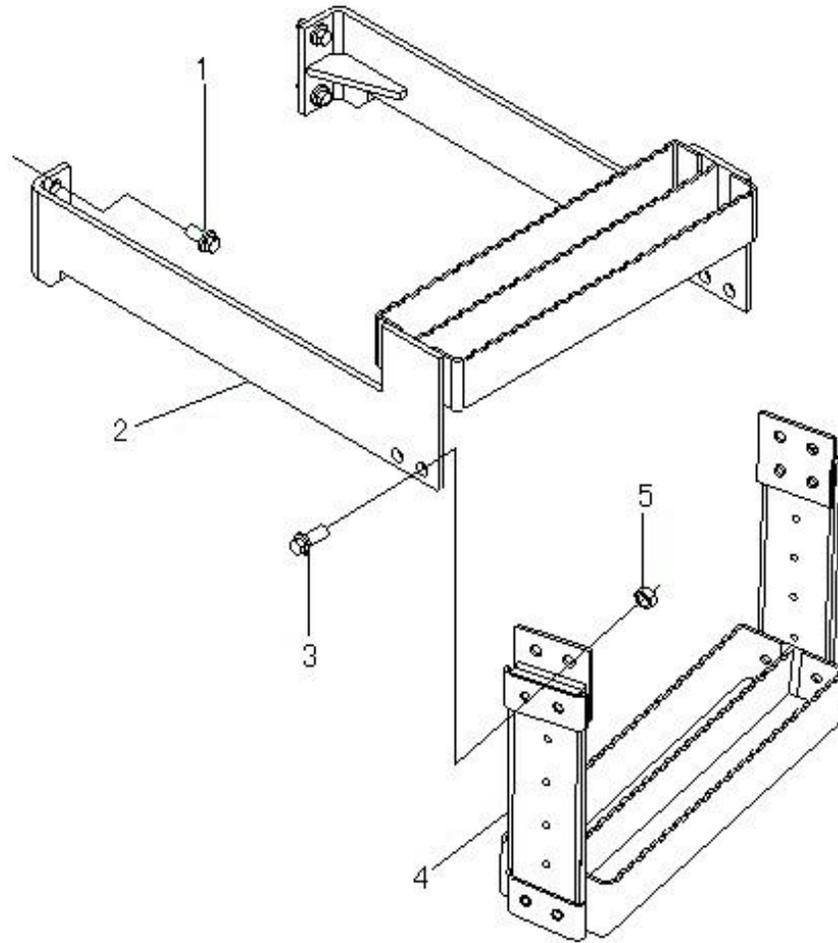

序号 Key	零件代号 Part No.	名称 Description	是否配件 Spare parts Y/N	数量 Qty	备注 Remarks	
1	4011000560	螺栓GB16674-M12*25EpZn-8.8	BOLT GB16674-M12*25EpZn-8.8	N	4	
2	29340012201	下梯	DOWN LADDER	Y	1	
3	4011000474	螺栓GB16674-M10*25EpZn-8.8	BOLT GB16674-M10*25EpZn-8.8	N	4	
4	29340000571	软梯	SOFT LADDER	Y	1	
5	4013000007	螺母GB6170-M10EpZn-8	NUT GB6170-M10EpZn-8	N	4	
6	29340010891	护罩	HOOD	Y	1	





**N 空调系统**  
**AIR CONDITIONER SYSTEM**

山东临工工程机械有限公司  
**SHANDONG LINGONG CONSTRUCTION MACHINERY CO.,LTD.**

暖风机 WARMING MACHINE

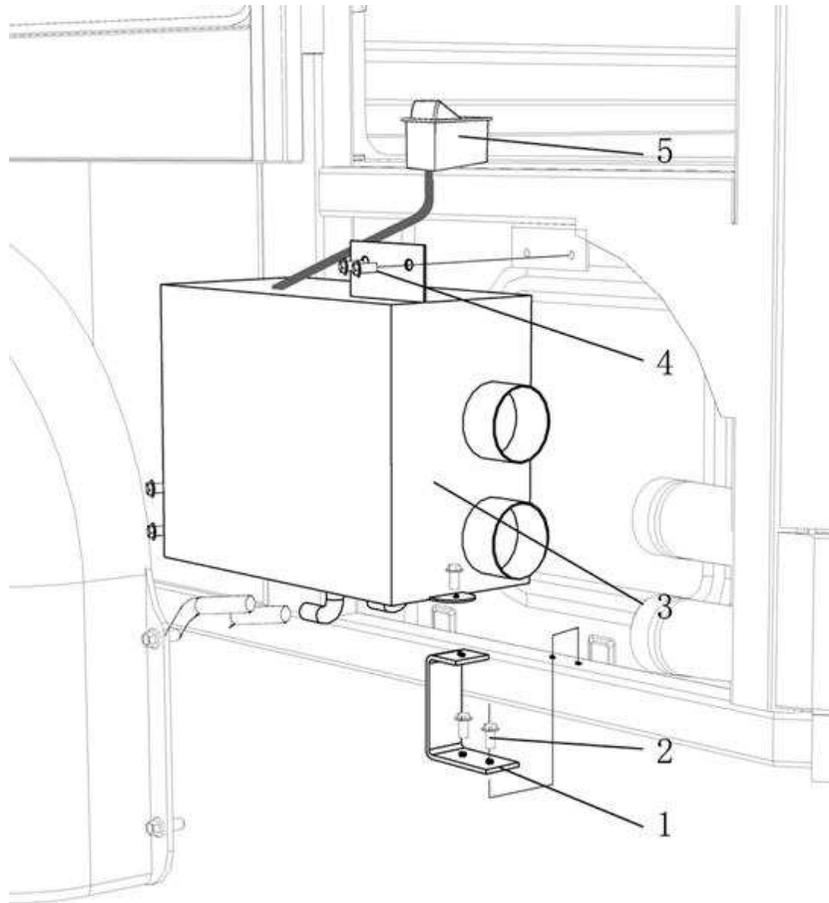

序号 Key	零件代号 Part No.	名称 Description	是否配件 Spare parts Y/N	数量 Qty	备注 Remarks	
1	29350008891	固定架	BRACKET	Y	1	
2	4011000154	螺栓GB16674-M6*20EpZn-8.8	BOLT GB16674-M6*20EpZn-8.8	N	3	
3	4190000917	暖风机BKC-II	WARMING MACHINE BKC-II	Y	1	
4	4011000458	螺栓GB16674-M8*20EpZn-8.8	BOLT GB16674-M8*20Ep.Zn-8.8	N	4	
5	4130000514	暖风机开关JK931-01NFJ	SWITCH OF WARMING MACHINE	Y	1	



暖风机 WARMING MACHING

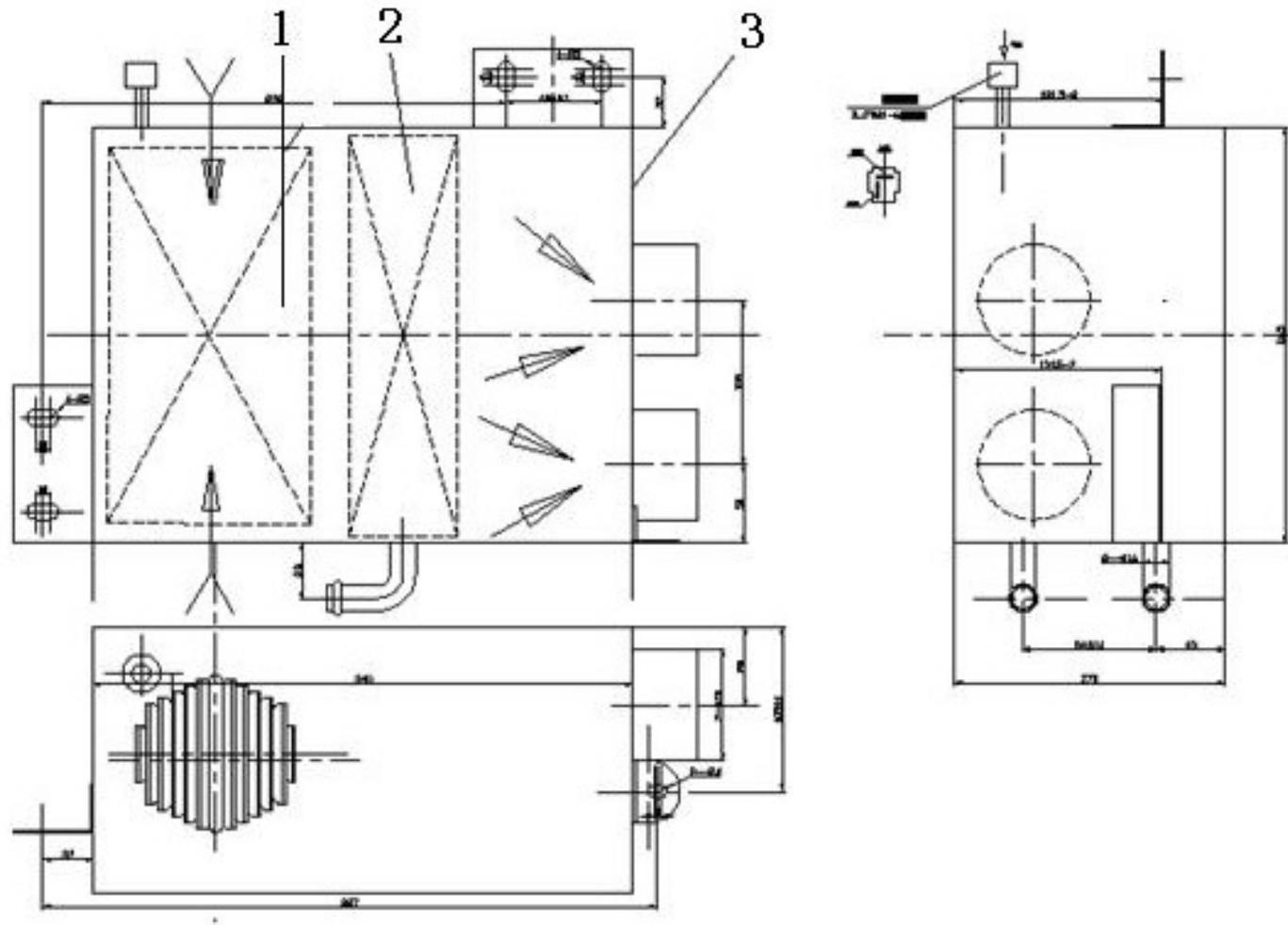

序号 Key	零件代号 Part No.	名称 Description	是否配件 Spare parts Y/N	数量 Qty	备注 Remarks	
1	4190000917001	散热器总成1301010	RADIATOR ASSEMBLY 1301010	Y	1	
2	4190000917002	电机风道总成8101030	MOTOR DUCT ASSEMBLY 8101030	Y	1	
3	4190000917003	壳体总成8101010	SHELL ASSEMBLY 8101010	N	1	





**0 电气系统**  
**ELECTRIC SYSTEM**

山东临工工程机械有限公司  
**SHANDONG LINGONG CONSTRUCTION MACHINERY CO.,LTD.**



序号 Key	零件代号 Part No.	名称 Description	是否配件 Spare parts Y/N	数量 Qty	备注 Remarks	
1	26370002451	红电瓶线护套	BATTERY WIRE JACKET (RED)	Y	2	
2	4011000461	螺栓GB16674-M8*16EpZn-8.8	BOLT GB16674-M8*16EpZn-8.8	N	9	
3	29370016801	电瓶线P50x1900	BATTERY WIRE P50x1900	Y	2	
4	29370016141	电瓶线P50x450	BATTERY WIRE	Y	1	
5	4130000427	电源开关K01K18-A	POWER SWITCH K01K18-A	Y	1	
6	29370016151	电瓶线A50x550	BATTERY WIRE A50x550	Y	1	
7	26370002441	黑电瓶线护套	BATTERY WIRE JACKET (BLACK)	Y	5	
8	4130000057	蓄电池6-QW-120B	BATTERY 6-QW-120B	Y	2	
9	4190000020	扎丝LG13-ZS4*250	CLIP LG13-ZS4*250	Y	60	
10	26370001911	管夹	CLAMP	Y	5	
11	4130000009	双音盆形喇叭DL125-24V	ELECTRIC HORN DL125-24V	Y	1	
12	4011000152	螺栓GB16674-M6*10EpZn-8.8	BOLT GB16674-M6*10EpZn-8.8	N	2	
13	4130000542	前左组合灯LFLDH4-24V	LEFT FRONT HEAD LAMP LFLDH4-24V	Y	1	
14	4130000543	前右组合灯LFRDH4-24V	RIGHT FRONT HEAD LAMP LFRDH4-24V	Y	1	
15	29370016011	前车架线束	FRONT FRAME WIRE	Y	1	
16	4130000329	隔膜式压力开关0166-40404-1-016	PRESS SWITCH 0166-40404-1-016	Y	1	
17	4130000910	压力开关YK210B	PRESSURE SWITCH YK210B	Y	1	
18	29040008901	接头体NPT1/8	CONNECTOR	Y	1	
19	4130000278	隔膜式压力开关310-LGK	DISSEPIMENT PRESSURE SWITCH310-LGK	Y	1	
20	29370016031	仪表台线束总成	PANEL HARNESS ASSEMBLY	Y	1	
21	29370016021	后车架线束总成	REAR BODY WIRING HARNESS	Y	1	
22	4130000213	后尾灯LRTD—24V	REAR LAMP LRTD—24V	Y	2	



序号 Key	零件代号 Part No.	名称 Description	是否配件 Spare parts Y/N	数量 Qty	备注 Remarks
23	413000121	倒车蜂鸣器KSHM-12F4	ANNUNCIATOR KSHM-12F4	Y	1
24	413000544	后大灯SPH4-1031	REAR LARGE LAMP SPH4-1031	Y	2
25	29370009331	后罩线束	COVER HARNESS	Y	1
26	4130000797	前照灯QZD-2	FORWARD LIGHTING QZD-2	Y	4
27	29370016042	仪表盘ZL2-235M	PANEL ZL2-235M	Y	1
28	4130000208	电锁08086-10000	STARTING SWITCH 08086-10000	Y	1
29	4130000912	蓄电池继电器024-1H2T-80A	BATTERY RELAY 024-1H2T-80A	Y	1
30	4130000290	转向开关JK802A	TURNING SWITCH	Y	1
31	29370012571	支承板	SUPPORTING PLATE	Y	1
32	4014000026	螺钉GB818-M6*16EpZn-4.8	SCREW GB818-M6*16EpZn-4.8	N	2
33	4015000207	垫圈GB97.1-6EpZn-300HV	WASHER GB97.1-6EpZn-300HV	N	2
34	29370012561	固定座	FIXED PEDESTAL	Y	1
35	29370012551	管夹	PIPE NIP	Y	1
36	4011000481	螺栓GB16674-M8*30EpZn-8.8	BOLT GB16674-M8*30Ep.Zn-8.8	N	2
37	4130000869	中间继电器024-1Z6GD2	AUXILIARY RELAY 024-1Z6GD2	Y	5
38	4130000496	盖板JK931-01GB	CAP JK931-01GB	Y	5
39	4130000499	喷水开关JK931-01PS	SPRAY WATER BUTTON-SWITCH JK931-01PS	Y	1
40	4130000917	后大灯开关JK931-02HDD	SWITCH,REAR HEADLIGHT K931-02HDD	Y	1
41	4130000555	前大灯开关JK931-01QDD	FRONT BIG LAMP BUTTON-SWITCH JK931-01QDD	Y	1
42	4130000491	后照灯开关JK931-01HZD	BACKWARD LIGHTING BUTTON-SWITCH JK931-01HZD	Y	1
43	4130000490	前照灯开关JK931-01QZD	FORWARD LIGHTING BUTTON-SWITCH JK931-01QZD	Y	1
44	4130000489	背光灯开关JK931-01BGD	BACK LAMP BUTTON-SWITCH JK931-01BGD	Y	1

电气系统 ELECTRIC SYSTEM

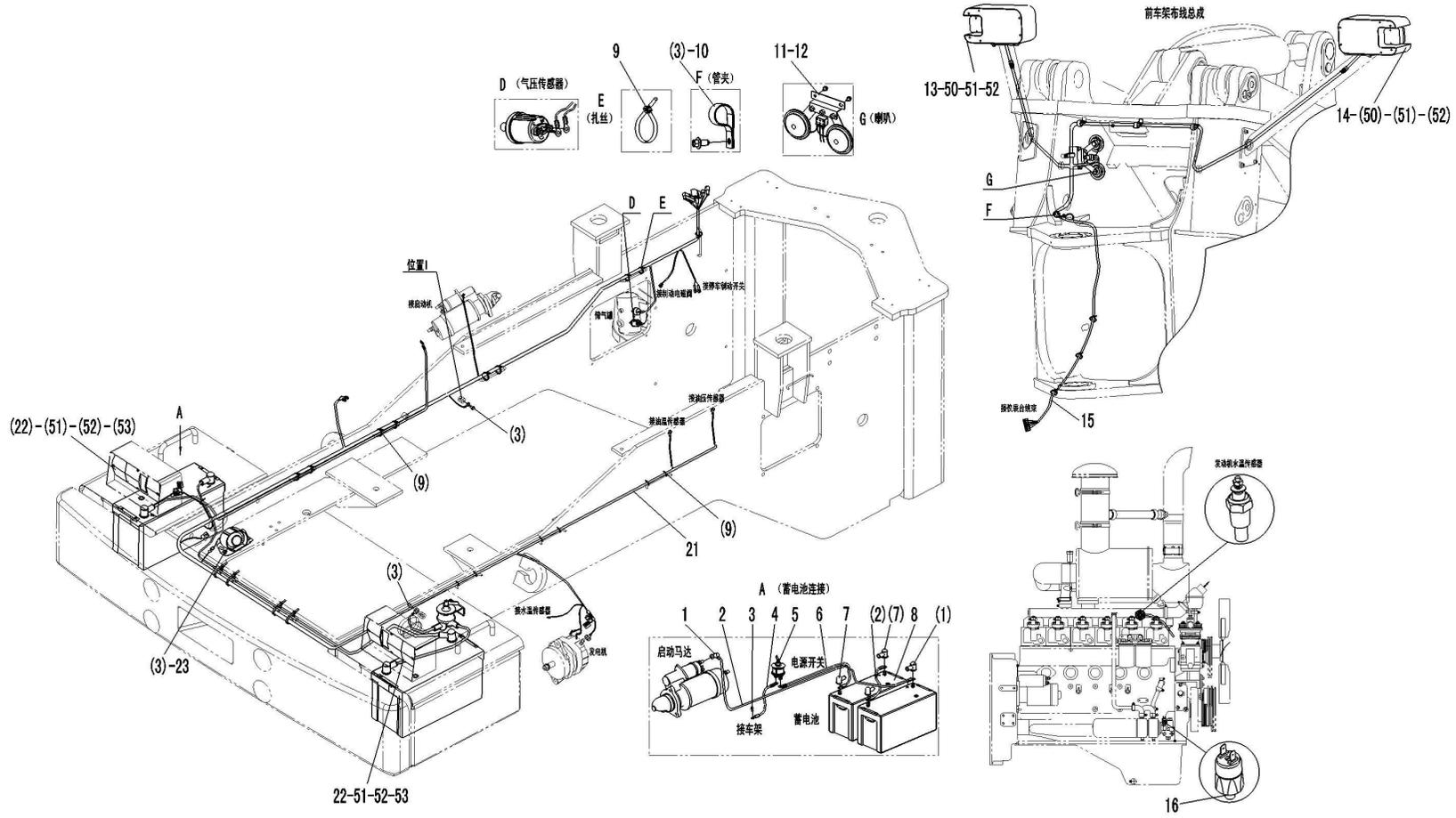

序号 Key	零件代号 Part No.	名称 Description	是否配件 Spare parts Y/N	数量 Qty	备注 Remarks
45	4130000492	警示灯开关JK931-01JSD	ALARM LAMP BUTTON-SWITCH JK931-01JSD	Y	1
46	4130000493	刮雨器开关JK931-01GYQ	WIPER BUTTON-SWITCH JK931-01GYQ	Y	1
47	4130000498	侧边单框架JK931-01CKJ	SIDE FRAME JK931-01CKJ	Y	6
48	4130000497	中间单框架JK931-01ZKJ	MIDDLE FRAME JK931-01ZKJ	Y	7
49	4130000060	手制动开关LA39-01Z	HAND BRAKE SWITCH LA39-01Z	Y	1
50	4130000643	灯泡LIFE H4(24V 75W/70W)	BULB LIFE H4(24V 75W/70W)	Y	4
51	4130000618	灯泡PHILIPS 13498(24V 21W)	Bulb	Y	4
52	4130000916	灯泡PHILIPS 13814(24V 10W)	BULB PHILIPS 13814(24V 10W)	Y	4
53	4130000915	灯泡PHILIPS 13499(24V 21W/5W)	BULB PHILIPS 13499(24V 21W/5W)	Y	2
54	4130000620	灯泡PHILIPS 13336 H3	Bulb	Y	4

仪表盘总成 PANEL ASSEMBLY

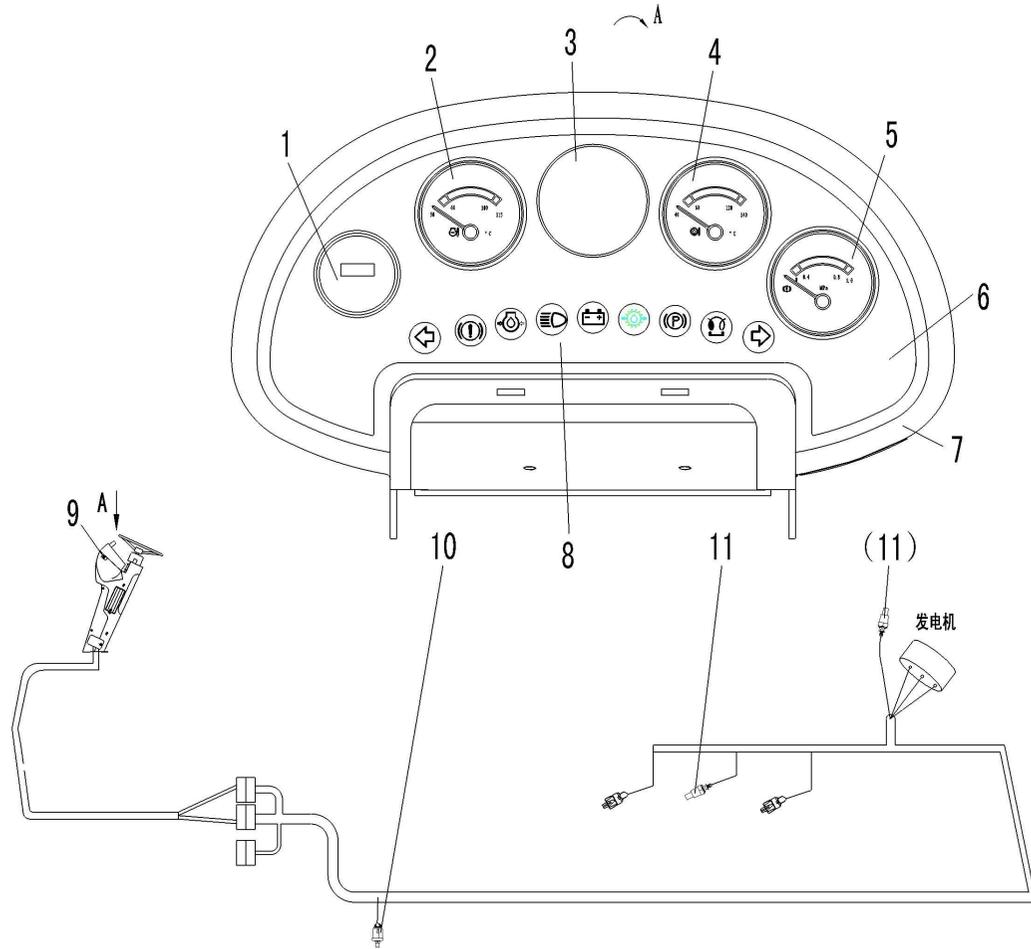

序号 Key	零件代号 Part No.	名称 Description	是否配件 Spare parts Y/N	数量 Qty	备注 Remarks	
1	4130000956	计时表R8865A-3	WORKING HOUR METER R8865A-3	Y	1	
2	4130000215	水温表SW242-2A	ENGINE WATER TEMPERATURE GAUGE SW242-2A	Y	1	
3	4130000822	仪表孔盖板	COVER BOARD,INSTRUMENT HOLE	Y	1	
4	4130000217	变矩器油温表YW242-2B	TORQUE CONVERTER OIL TEMPERATURE GAUGE YW242-2B	Y	1	
5	4130000218	制动气压表YY242-2L	BRAKE AIR PRESSURE GAUGE YY242-2L	Y	1	
6	4130000467	仪表盘面板ZL2-235H2-1	PANEL ZL2-235H2-1	Y	1	
7	4130000466	仪表盘壳体ZL2-220-101	PANEL SHELL ZL2-220-101	Y	1	
8	4130000953	指示灯组件ZL2-235M-008	INDICATOR PARTS ZL2-235M-008	Y	1	
9	4130000022	闪光器SG252	FLASH RELAY SG252	Y	1	
10	4130000308	制动气压传感器YG901C3	BRAKE AIR PRESSURE SENSOR YG901C3	Y	1	
11	4130000202	温度传感器WDG1371	ENGINE WATER TEMPERATURE SENSOR WDG1371	Y	2	

